

JIBBI

U-1570



PATENT PENDING



U **ULTRA**
LIGHT
CRAWLER RANGE

PRO ACTIVE LEVELLING

DYNAMIC LEVELLING

CRAWLER TELESCOPIC BOOM

ALMACRAWLER

JIBBI U-1570

Piattaforma cingolata
telescopica ultraleggera di 2,9 t
per 15,40 m di altezza.

Self-propelled crawler lift with an
Ultralight Telescopic boom, 2,9 t
weight and 15,4 m working height.

ALMACRAWLER



Dati tecnici	EVO	LTH	Technical data
Altezza massima di lavoro	15,40 m		Max working height
Altezza piano calpestio	13,40 m		Max height basket floor
Altezza di traslazione massima	9,50 m		Max moving height
Sbraccio massimo (carico 80 Kg)	9,65 m		Max outreach (load 80 kg)
Sbraccio massimo (carico 140 Kg)	8,23 m		Max outreach (load 140 kg)
Sbraccio massimo (carico 200 Kg)	7,33 m		Max outreach (load 200 kg)
Sbraccio massimo (carico 250 Kg)	6,83 m		Max outreach (load 250 kg)
Angolo di rotazione torretta	+/-110°		Rotation angle
Dimensioni navicella	1,4 x 0,7 m		Basket size
Angolo di rotazione navicella	+/- 90°		Basket rotation angle
Portata massima in navicella	250 kg (2 p.)		Max basket capacity
Lunghezza richiusa	4,92 m		Length in stowed position
Larghezza minima richiusa	1,35 m		Min width in stowed position
Larghezza media di lavoro	1,98 m		Med working width
Larghezza massima di lavoro	2,45 m		Max working width
Altezza minima richiusa	1,99 m		Min height in stowed position
Livellamento longitudinale	+/- 15°		Longitudinal leveling
Livellamento laterale	+/- 15°		Lateral leveling
Pendenza massima superabile	25°		Max gradeability
Pendenza laterale massima	25°		Max side gradeability
Velocità traslazione (veloce)	2,5 km/h	2,0 km/h	Drive speed (max)
Velocità di traslazione in quota		0,4 km/h	Max speed while at height
Pesi			Weight
Carico al suolo	3,40 kN/m2	3,50 kN/m2	Traffic load (max working width)
Peso totale	~ 2895 kg	~ 2950 kg	Total weight
Potenza			Power
Motore Yanmar 3TNM68-AS diesel	14 kW - 19,2 Hp @3600rpm	No	3TNM68 -AS Yanmar engine (diesel)
Lithium battery pack 300Ah-48V	No	DC 4 kW	Lithium battery pack 300Ah-48V
N° 2 battery charger 20Ah-48V (Re-charging time)	No	6 h	N° 2 battery charger 20Ah-48V (Re-charging time)
Allestimenti a richiesta			Extras - On Demand
Cingoli antitraccia	-	-	Non-marking tracks
Elettropompa 220V-2,2Kw / 50Hz	-	-	Electric pump 220V-2,2KW / 50Hz
Kit radiocomando con batteria ricaricabile	-	-	Radio remote control with rechargeable battery
Kit lubrificante per clima artico	-	-	Arctic lubricant for cold climate
Sistema Anti-collisione ad ultrasuoni	-	-	Ultrasonic Anti-collision System

MyAlmac

CONTROL PANEL



Pannello remoto per la gestione della macchina
Remote equipment management control panel

Sistema anti-collisione ad ultrasuoni
Ultrasonic anti-collision system

Portata massima in navicella 250 kg
Max basket capacity 250 kg

Braccio telescopico ultraleggero con JIB in alluminio
Ultralight aluminium telescopic boom and jib

Integrated Drive System

Guida a singolo joystick
Single joystick driving

Console via cavo by AUTECH
Cable remote console by AUTECH

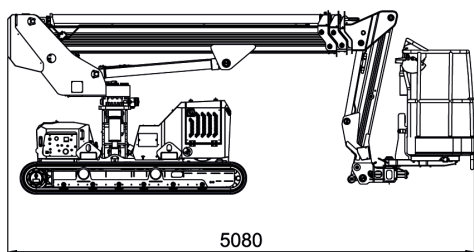
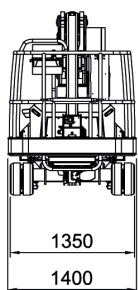
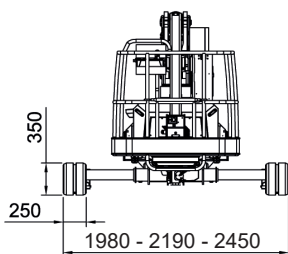

Livellamento combinato massimo 22°
Mix leveling up to 22°

ULTRALIGHT
CRAWLER RANGE

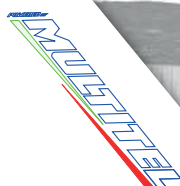

Nata dalla sinergia fra **AlmaCrawler** e **Multitel Pagliero** la **Serie Ultralight**, esprime la perfetta fusione fra innovazione e tradizione, proponendo in un unico prodotto un mix di prestazioni uniche nel loro genere.

Multitel Pagliero forte di una comprovata esperienza nella lavorazione dell'alluminio ha realizzato un **Braccio Ultraleggero** prodotto con una speciale lega che ne rende la struttura robusta e dal peso estremamente contenuto; tecnologia questa che, unita all'innovazione e al know-how del **Sottocarro Livellante** di AlmaCrawler, ha consentito la realizzazione di un semovente cingolato con un'altezza di lavoro superiore ai 15 metri ed una massa complessiva inferiore ai 2.9 t, mantenendo invariata la possibilità di lavorare in quota in presenza di terreni sconnessi e/o su forti pendenze (fino a 22°).

Resulting from the partnership between **AlmaCrawler** and **Multitel Pagliero**, the **Ultralight Series** represent the perfect combination of innovation and tradition, offering a mix of unique characteristics in a single product.

The **Ultralight Boom** produced by Multitel Pagliero with a special aluminum alloy allows for a solid yet light structure. This technology combined with the innovative AlmaCrawler **Bi-Levelling Undercarriage**, has resulted in a self-propelled tracked vehicle with a working height of 15.4 meters and a total weight of less than 2900 kg, able to travel at height on uneven ground and/or steep slopes (up to 22°) thanks to the Dynamic and Pro-Active Leveling technology.

JIBBI U-1570

15.4m

250kg

19.2Hp

+/-15°

2.5km/h

+/-15°

MAX W.H.

CAPACITY

POWER

LONG. LEVEL.

SPEED

LATER. LEVEL.

Dynamic Working Performance

Controllo progressivo dello sbraccio in funzione delle reali condizioni di lavoro (portata in cesta, carreggiata, inclinazione terreno).

- 80 kg
- 140 kg
- 200 kg
- 250 kg

Progressive outreach control based on the real working conditions (basket capacity, track width, ground inclination).

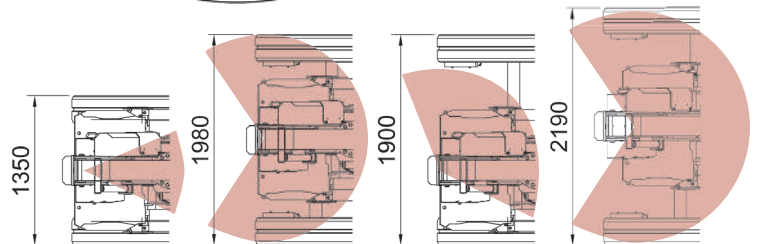
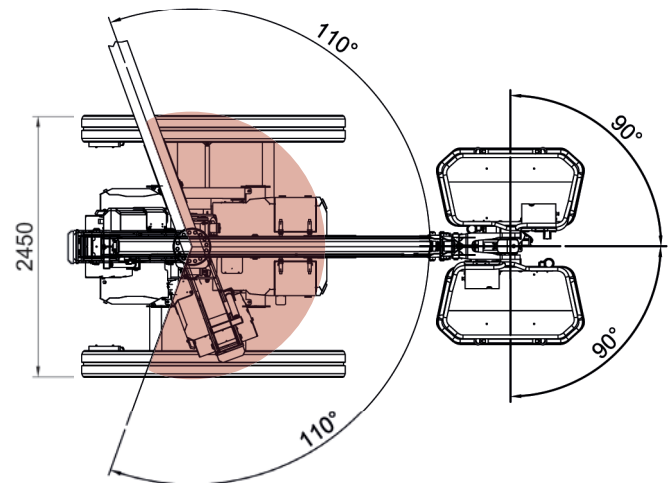
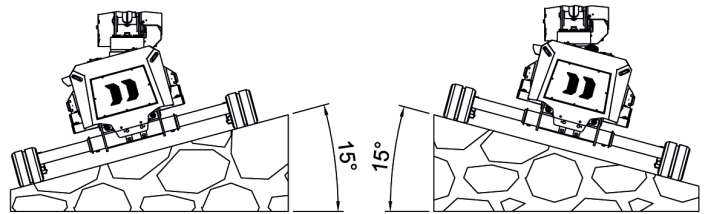
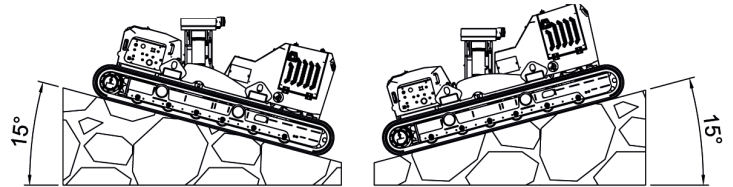
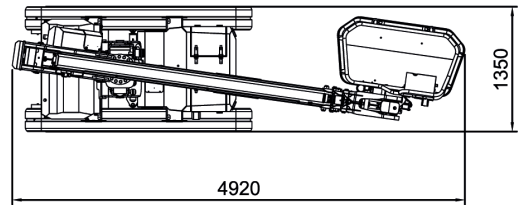
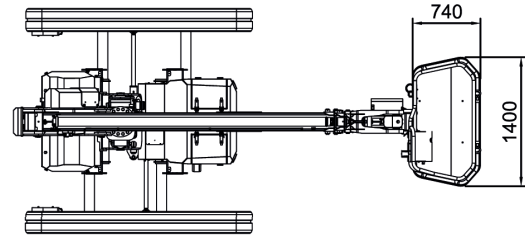
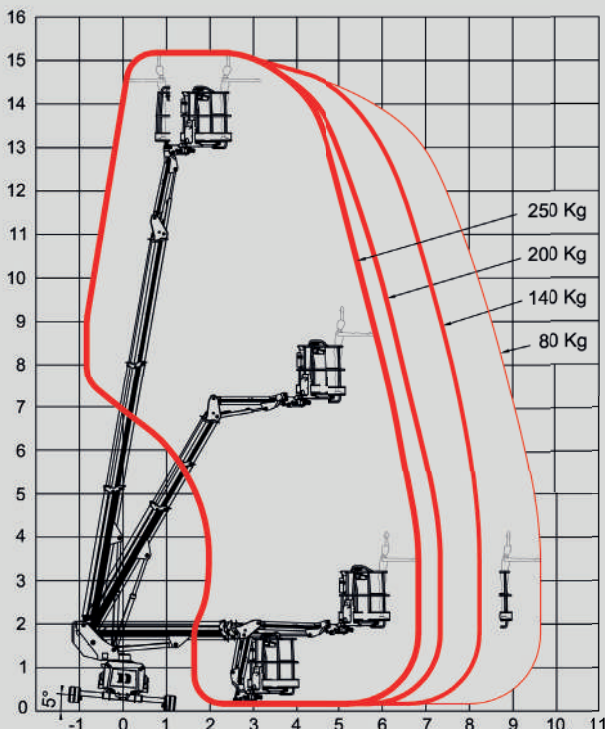
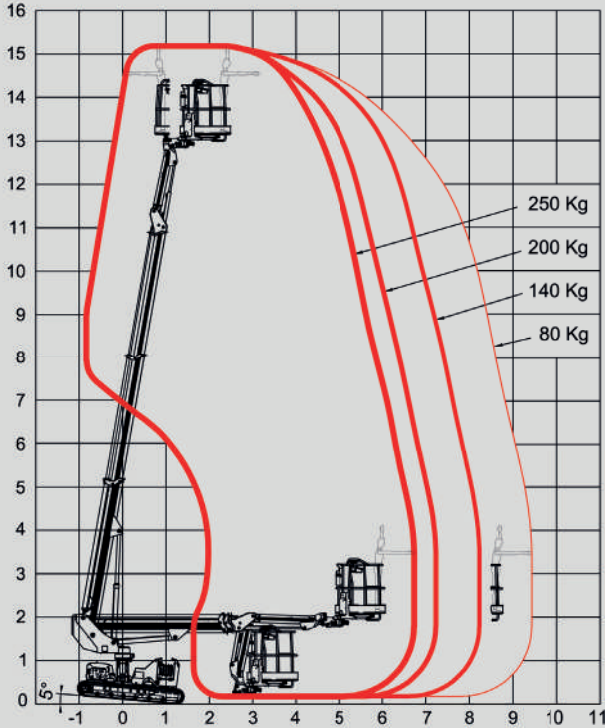

SILCOMNORTH UAB

www.silcomnorth.com

hello@silcomnorth.com

Phone +370 67216691

A. Goštauto g. 8, Vilnius 10312, Lithuania

ALMACRAWLER

ALL DATA REPORTED IN THIS CATALOGUE ARE NOT BINDING. ALMAC SRL RESERVES THE RIGHT TO CHANGE SPECIFICATIONS WITHOUT PRIOR NOTICE.