



# CWE 315

GRU CINGOLATA COMPATTA  
COMPACT CRAWLER CRANE  
KOMPAKTKRAN AUF ROLLSCHIENEN



**BG** LIFT  
by Brennero Gru 

LOW POSITION

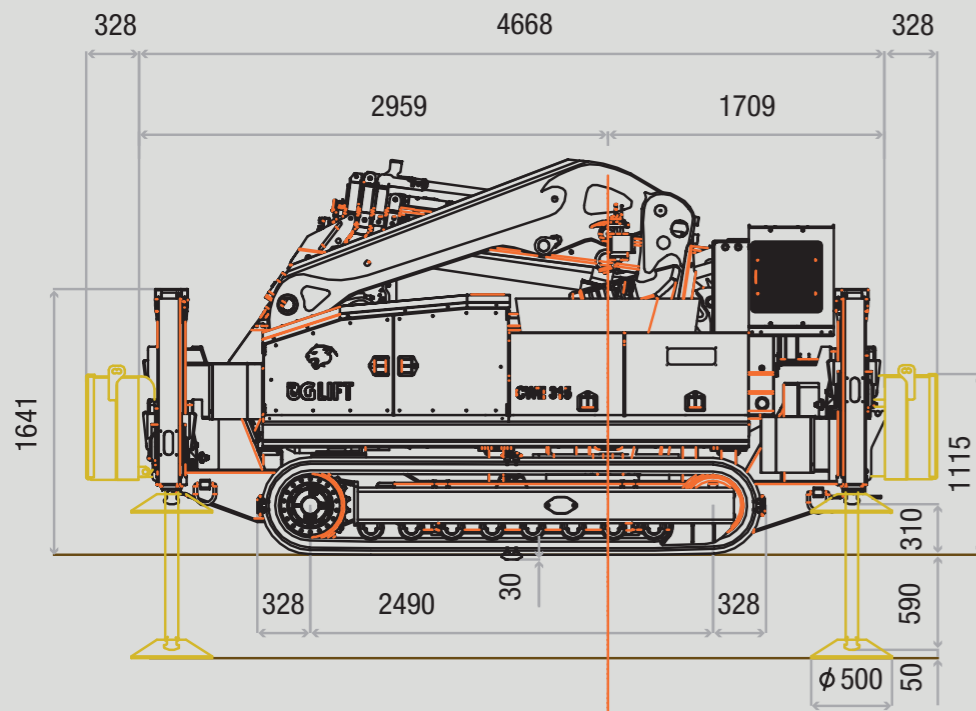

LOW POSITION

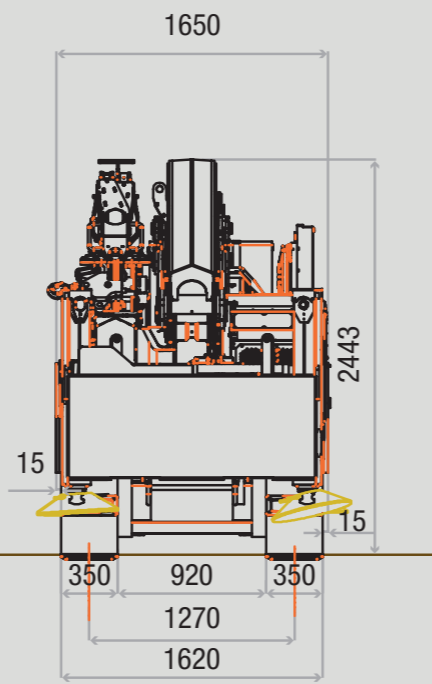

LOW POSITION

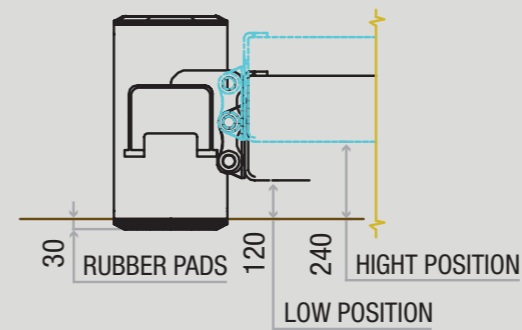
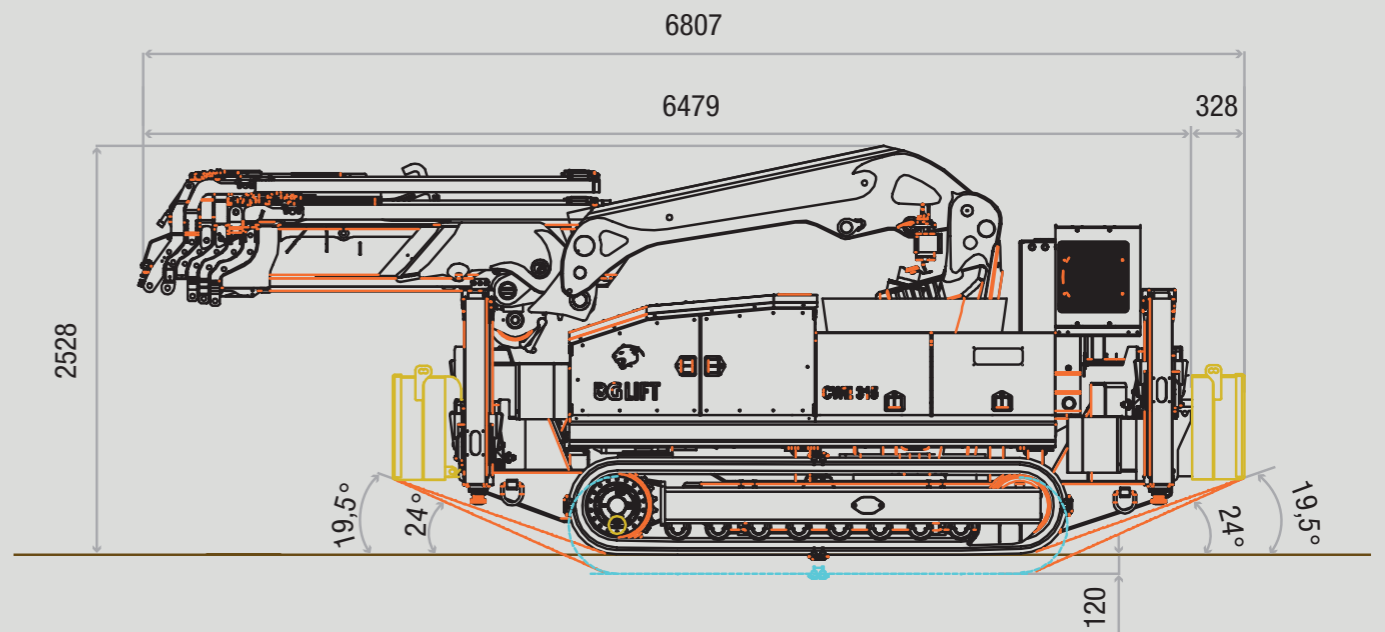

Technical data can be modified without prior notice

Technical data can be modified without prior notice

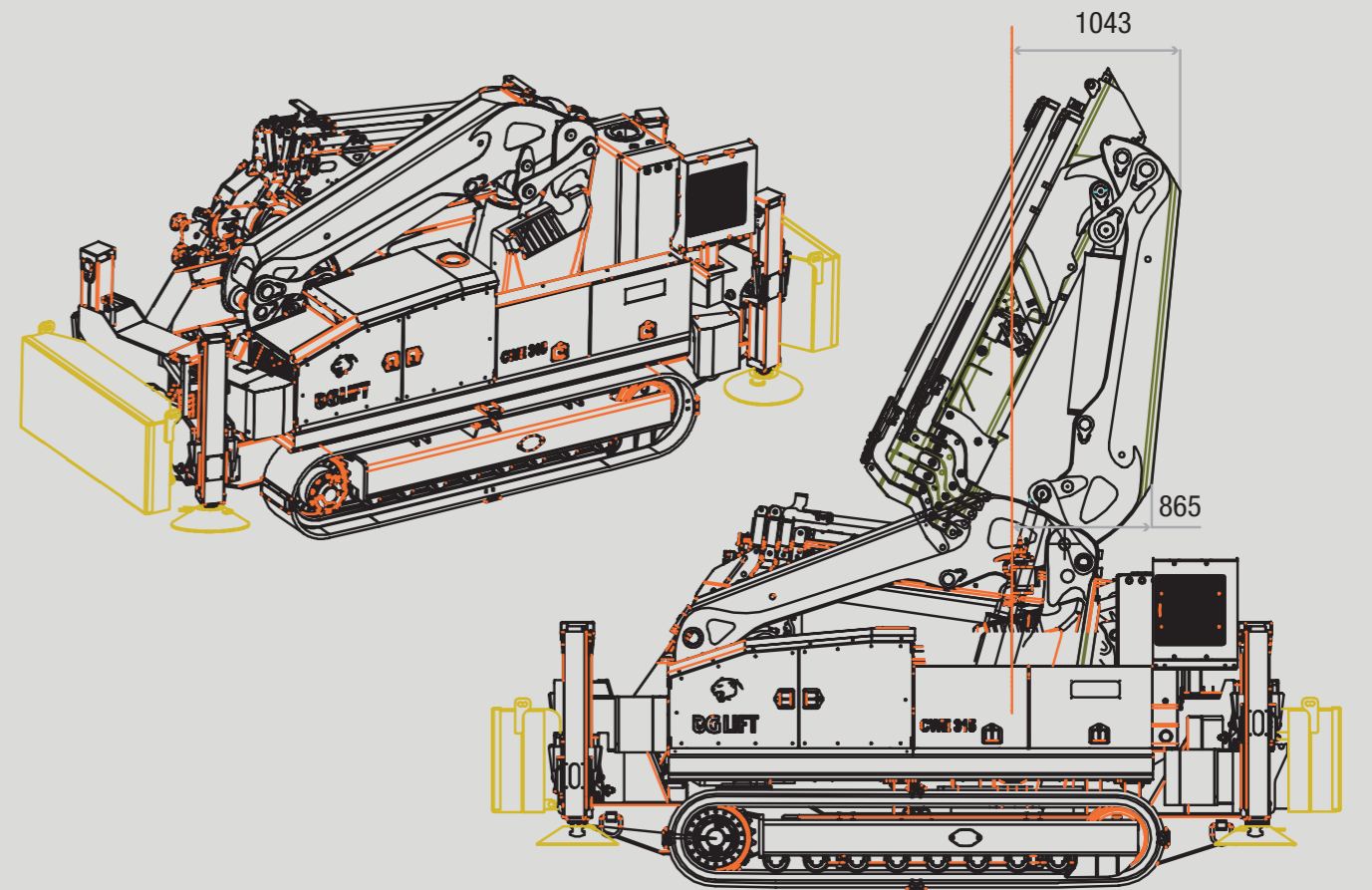
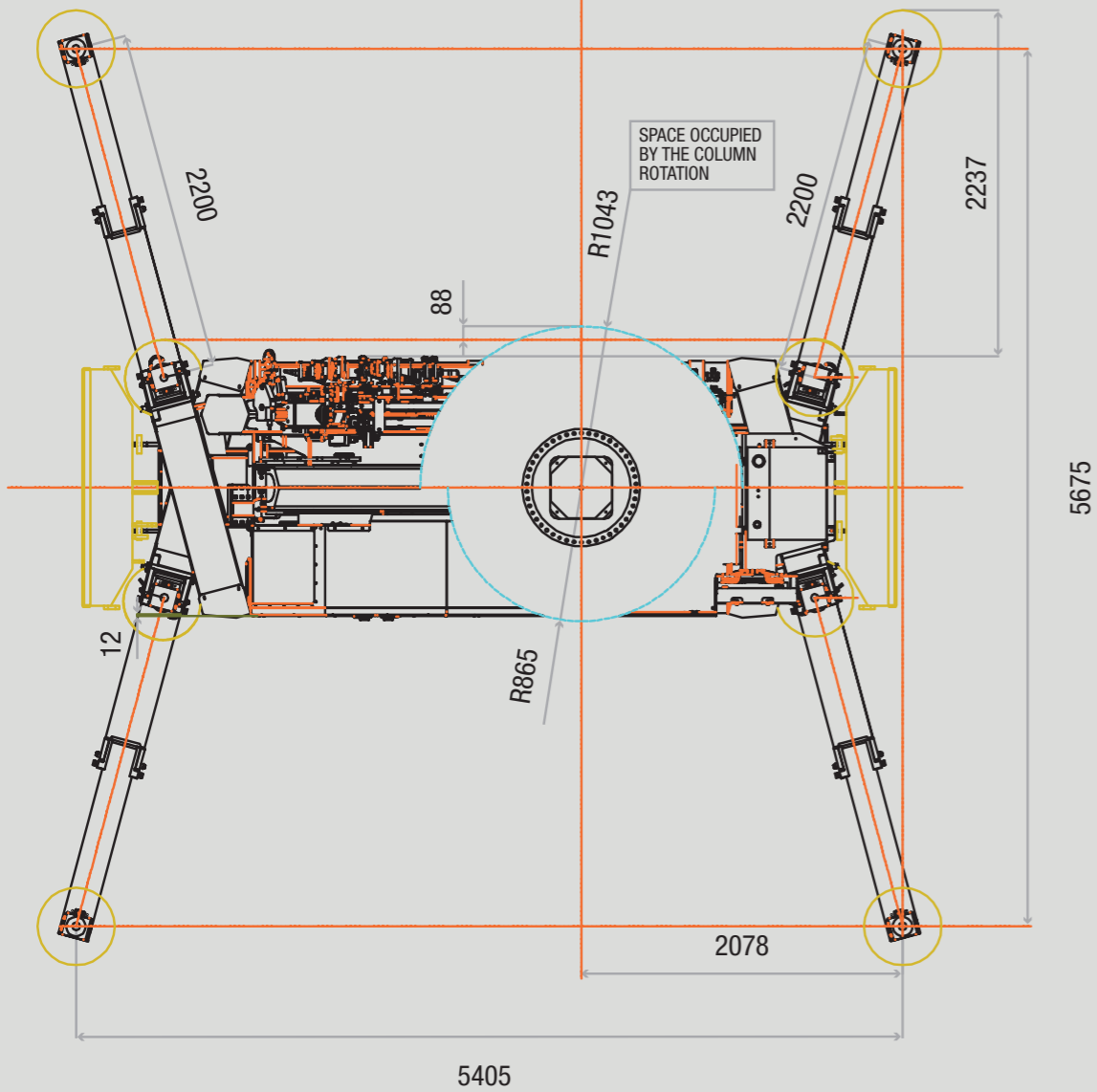



# CWE 315

Technical data can be modified without prior notice

## CWE 315. Leggera, compatta, potentissima

La gru geniale, dalle performance fino ad ora reputate impossibili. CWE 315 è un progetto esclusivo di BG LIFT, nato dall'esigenza di creare una gru compatta e leggera, ma nel contempo forte e potente come le sue colleghe di dimensioni superiori. I risultati? Oltre 26 metri di sbraccio orizzontale e quasi 10 tonnellate di capacità massima di sollevamento in uno chassis ridotto, agile ed estremamente manovrabile.

### Tecnologia:

**Every Function Under Control** Il radiocomando proporzionale multifunzione con display per controllo integrato, consente anche di visualizzare in tempo reale tutti i parametri della macchina.

**No Limits Rotation** La zavorra mobile montata sul carro permette la rotazione continua in sagoma.

**Always Ready to Work** Telaio ad "X" che consente di lavorare con gli stabilizzatori in sagoma e l'ingombro al minimo.

**Easy To Drive** Può stabilizzare e lavorare in terreni scoscesi.

**Load & Transport** La compattezza e l'ampio angolo di attacco permettono di caricare la gru utilizzando rampe corte.

**Jib Over Line** Lunghezza e portata del Jib da record.

**Electric Engine Always Allowed**

Motore elettrico trifase 15 Kw/400V controllato da inverter.



## CWE 315. High Performance in Tight Space

The brilliant crane, with performances that until now were considered impossible. CWE 315 is an exclusive project of BG LIFT, born from the need to create a compact and light crane, but at the same time strong and powerful as his colleagues of higher dimensions. The results? More than 26 meters of horizontal outreach and almost 10 Ton of maximum lifting capacity in a reduced chassis, agile and extremely maneuverable

### Technology:

**Every Function Under Control** The multifunction proportional radio control provided with an integrated control display, permits as well to verify in real time all the parameters of the machine.

**No Limits Rotation** The removable Ballast mounted on the Chassis permits the continuous "in shape" Rotation.

**Always Ready to Work** The "X" configuration allows to operate with narrow outriggers and minimum obstruction.

**Easy To Drive** The Machine can level and operate on steep grounds.

**Load & Transport** The compactness and the wide ground clearance angle allows the crane to be loaded using Short ramp.

**Jib Over Line** Noteworthy Jib Length and Load.

**Electric Engine Always Allowed**

15 Kw Three Phases Electric Engine, 400V inverter controlled.

## CWE 315. Viel Leistung in wenig Platz

Der geniale Kran mit Leistungen, die bisher als unmöglich galten. CWE 315 ist ein exklusives Projekt von BG LIFT, geboren aus der Not einen kompakten und leichten Kran zu schaffen, aber gleichzeitig stark und so mächtig wie seine Kollegen höherer Dimensionen. Die Ergebnisse? Über 26 Meter seiten-reichweite und fast 10 Tonnen maximale Kapazität Heben in einem reduzierten Fahrgestell, wendig und extrem manövrierfähig.

### Technologie:

**Every Function Under Control** Die Proportionale Multifunktions-Fernbedienung mit Display und Integraler Kontrolle, ermöglicht den kompletten Überblick aller Parameter der Maschine. **No Limits Rotation**

Das auf dem Rahmen montierte mobile Ausgleichsgewicht, ermöglicht eine bedingungslose Rotation des Krans. **Always Ready to Work**

Die X- Konfiguration des Rahmens ermöglicht das Arbeiten mit eingefahrenen Stabilisatoren bei minimalen Platz-Dimensionen. **Easy To Drive**

Ermöglicht auch auf weichen und unebigen Grund eine Stabilisierung des Krans. **Load & Transport**

Die Kompakte Bauart des Krans, ermöglichen aufgrund der Bodenfreiheit, eine problemlose Auf und Ab-Ladung für den Transport. **Jib Over Line**

**Electric Engine Always Allowed**

15 Kw/400V Dreiphasen-Elektromotor mit Inverter.



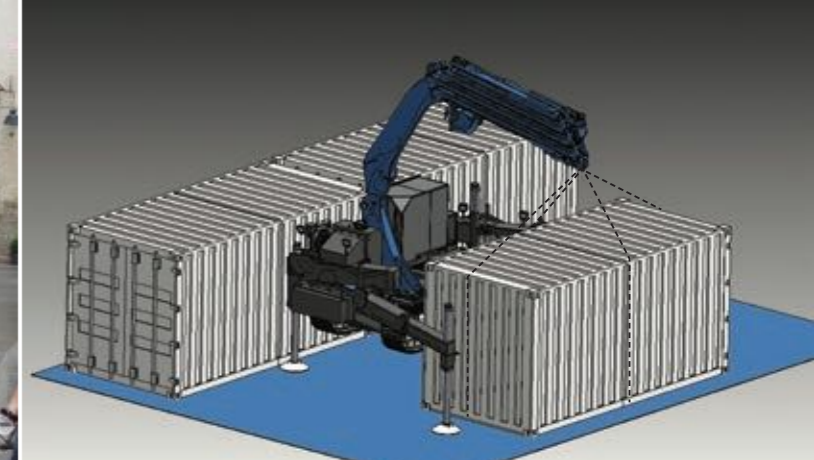

## CWE 315 / TECHNOLOGY APPLICATIONS



### Stabilizzazione in pendenza

Gli stabilizzatori delle gru **CWE 315**, con il sistema a traverse incrociate, conferiscono al basamento della gru un'incomparabile resistenza torsionale mantenendo estremamente compatte le dimensioni di ingombro in assetto di trasferimento.

I cilindri di stabilizzazione, robusti con corsa maggiorata, facilitano la tenuta della gru su terreni fortemente scoscesi.

### Sloping Stabilization

The outriggers of **CWE 315** Range, Provided With Cross Beams System, confer to the Crane Chassis an incomparable torsion resistance always keeping extremely Compact the machine Dimensions in rest position.

The outriggers cylinders, solid with extended stroke, Simplify the Crane Endurance on strongly steep grounds.

### Stabil auch in Hang-Situationen

Die Stabilisatoren der Gamma **CWE 315**, verfügen über eine Kreuz-Traverse, die dazu beitragen beim basieren des Krans, extremen widerstand auf Torsion zu leisten, um somit die kompakten Dimensionen bei Bewegung des Krans zu erhalten.

Die Zylinder der Stabilisatoren, sind robust und haben einen längeren Hub, ermöglichen somit den Kran eine sichere Stabilisation auf weichen und unebigen Untergrund.

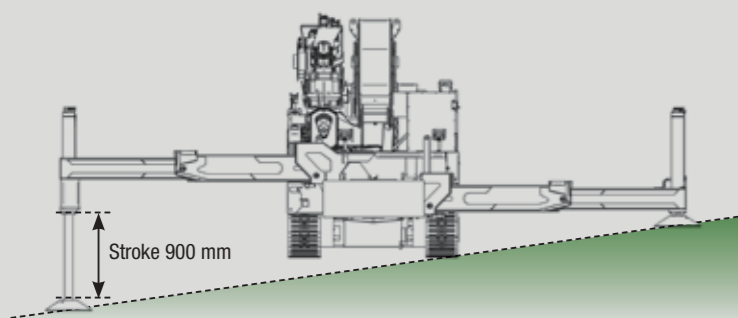

### Gestione del carico

Un largo impiego di acciai speciali ad alto limite di snervamento come lo **STRENX 1300**, consente di contenere il peso a vantaggio delle prestazioni, soprattutto nelle portate più esterne in punta al JIB.

### Load Management

A large Employment of high enervation limit special steels, such as **STRENX 1300**, allow to limit the weight in order to take advantage of the performance; especially with more external loads on the top of the Jib.

### Zuladung

Der Einsatz von speziellem Stahl wie **STRENX 1300**, ermöglichen einen ideale Gewichtverlagerung das sich Vorteilhaft auf Leistungen auswirkt, speziell bei Einsätzen mit weit ausgefahrenen JIB.

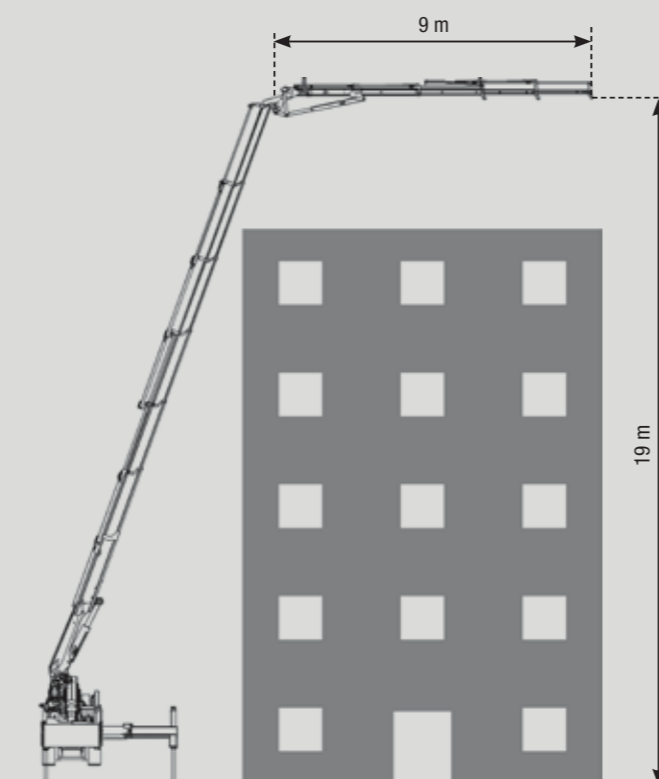

*Technical data can be modified without prior notice*

### Trasporto

Gli ampi angoli d'attacco consentono di caricare la macchina su autocarri anche con rampe corte. Facilitando le manovre e ottimizzando i tempi di carico.

### Transport

The generous ground clearance angle permit to load the machine as well on truck with short ramps; simplifying the manoeuvres and optimizing loading time.

### Transport

Die Bauart des Krans, ermöglichen aufgrund der Bodenfreiheit, eine problemlose Auf und Ab-Ladung für den Transport, im geringen Zeitraum.

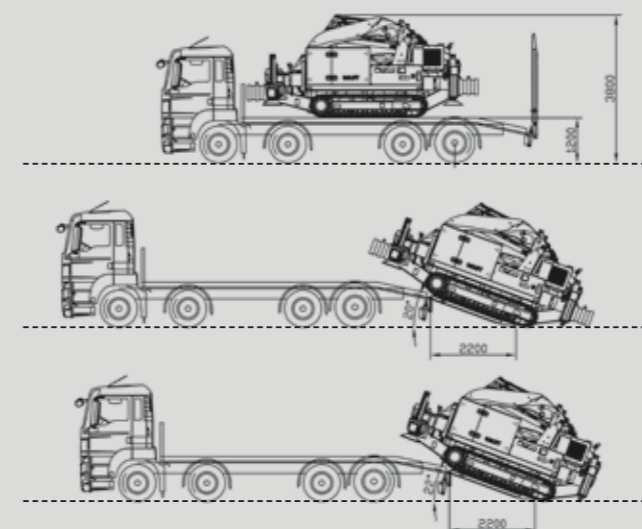

### Prestazioni a corto raggio

Le gru **CWE 315** è costruita con baricentri molto bassi, i quali, uniti alla geometria delle traverse incrociate, consentono di sviluppare la piena potenza ed abbracciare carichi pesanti e voluminosi (Macchine utensili e altro) operando a ridosso degli stessi in spazi ed altezze contenute.

### “Short ray” Performance

**CWE 315** is Built with very low barycentres which, combined to the Cross Beams Geometry, Permit to develop the full power and cover heavy and voluminous loads (Machines Tools and other) operating close to the load in reduced spaces and heights.

### Leistung bei kurzem Radius

Die Bauart der **CWE 315** hat einen niedrigen Schwerpunkt, das zusammen mit der Geometrie der Traversen, eine hohe Belastung bzw. Beladen des Krans (zb. Arbeitsmaschinen), bei geringen Platzmöglichkeiten ermöglichen.

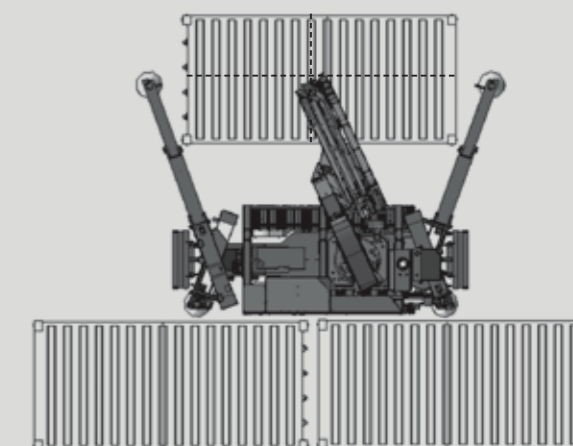

*Technical data can be modified without prior notice*



## CWE 315 / TECHNOLOGY APPLICATIONS



### Stabilità con limitazione del carico (Progress)

Il Sistema di controllo integrato consente alla gru infinite possibilità di stabilizzazione adeguando automaticamente il limitatore di carico alla situazione determinata dalla posizione di ogni stabilizzatore consentendo all'operatore di lavorare in sicurezza, e nel contempo, impostando configurazioni fino ad ora impensabili.

### Load Limit Stability (Progress)

The integrated control system give to the Crane infinite Stabilization possibilities, Automatically upgrading the load limiting device to the situation determined by the position of each outriggers; permitting the operator to completely work in safety conditions and, simultaneously, setting configurations unthinkable until today.

### Stabilität mit automatischer Abregelung des Gewichts (Progress)

Das integrierte Kontrollsystem des Krans, ermöglicht unendliche Möglichkeiten zur Stabilisierung, passt dabei automatisch den Sicherheitsregler an jede Position des Krans an, um somit das Arbeiten mit höchster Sicherheit zu ermöglichen, und zugleich eine Konfiguration des Krans, wie zuvor nicht Erdenklich.

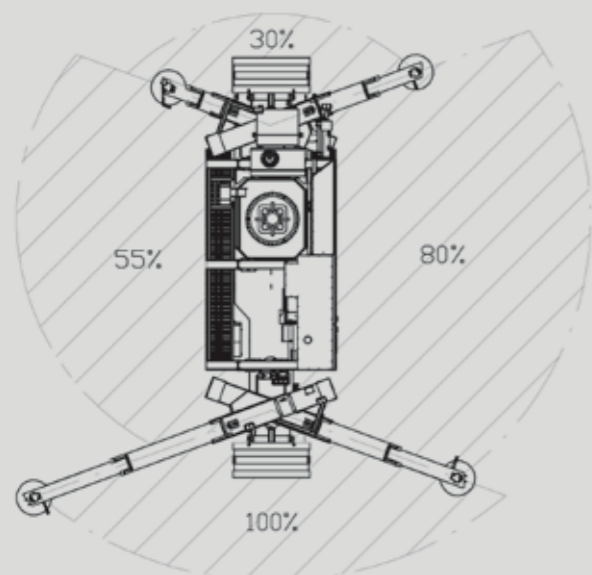

### Angolo positivo per accessi difficili (JOL)

Il secondo braccio articolato telescopico ed il Jib idraulico telescopico hanno un'operatività angolare rispettivamente di 15° e di 20° al di sopra dell'allineamento orizzontale del braccio. Tale soluzione consente di operare all'interno di edifici con la possibilità di superare ostacoli come travi, soppalchi e portoni.

### Positive Angle for Hard Access

The second Articulated Telescopic Boom and the Hydraulic Jib have angular operating system respectively of 15° and 20° Over the Horizontal alignment of the boom. This situation allow to operate inside buildings and give the possibility to overcome obstacles such as lofts, front door and Beams.

### Positiver Winkel für extrem schwierige Einfahrten

Der zweite gelenkte teleskopische Arm und der hydraulisch gesteuerte und teleskopische JIB, haben einen Schließwinkel von 15° und 20°, über der horizontaler Ausrichtung des Arms. Diese Lösung ermöglicht die Betreibung der Maschine auch in engen und niedrigen Gebäuden bzw. Räumlichkeiten, mit niedrigen Decken und Tore.

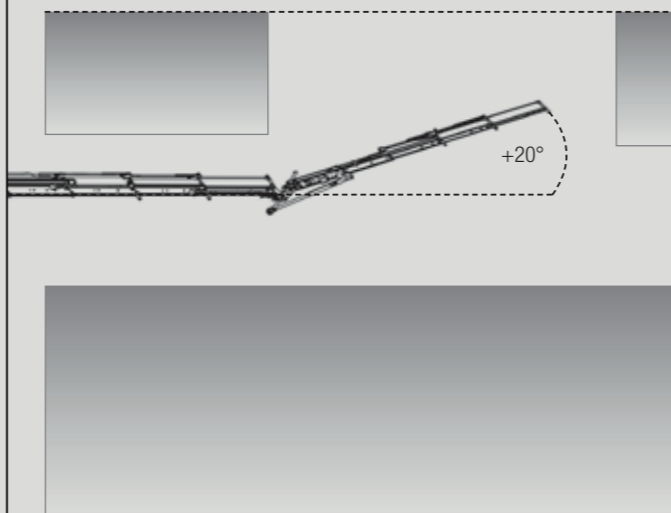

Technical data can be modified without prior notice

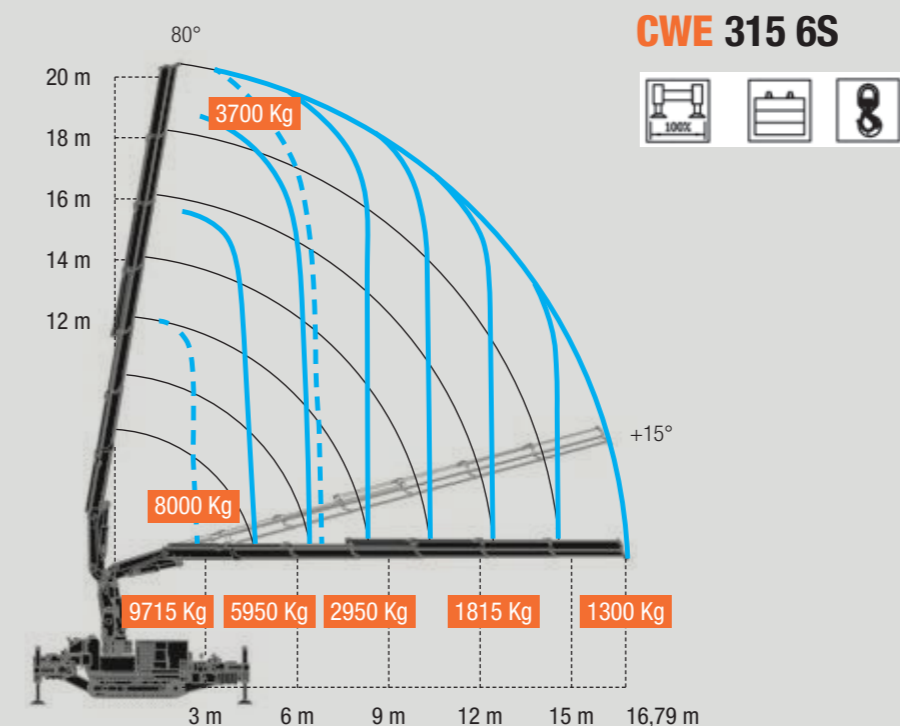
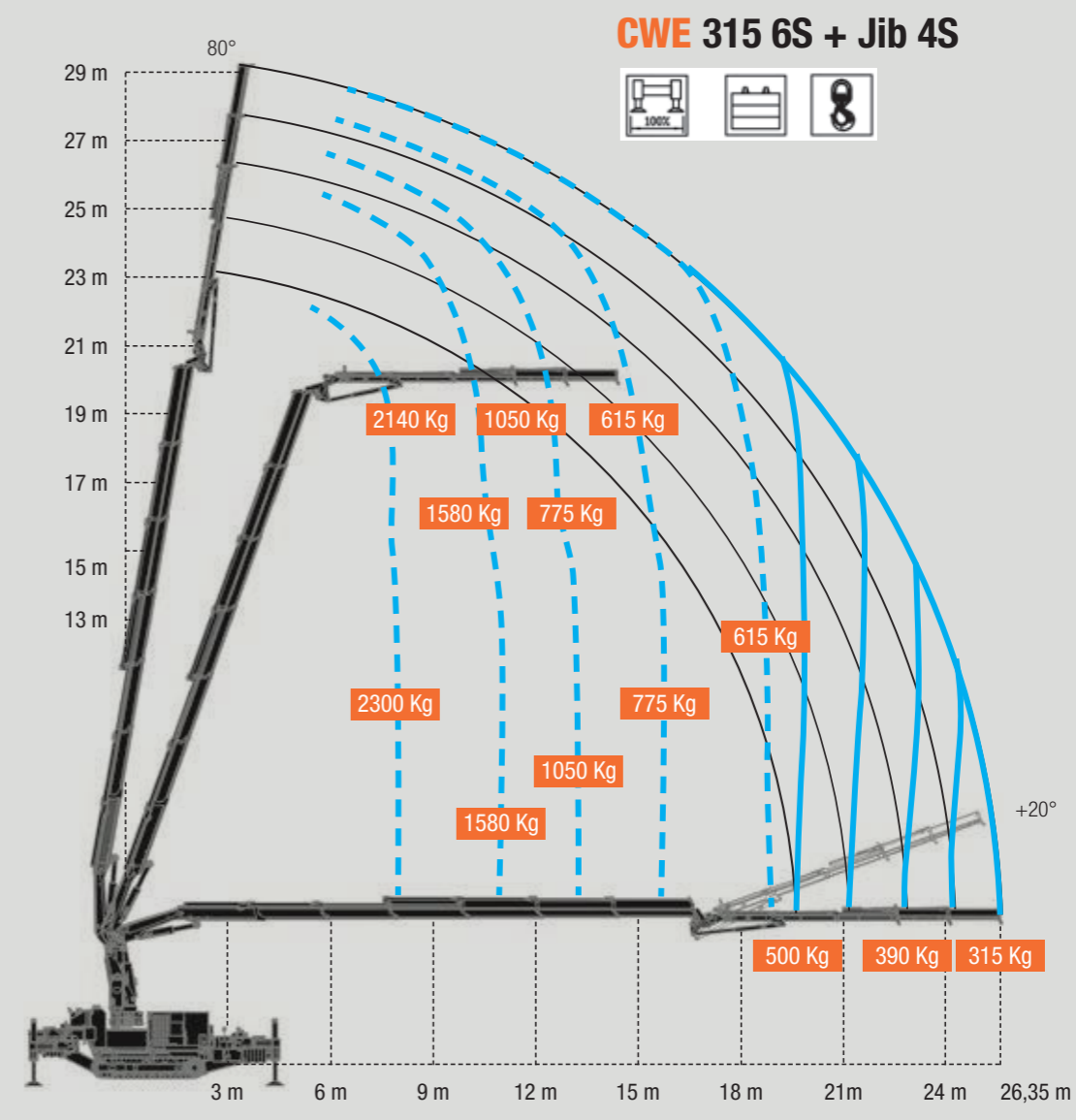

Technical data can be modified without prior notice



	Carico massimo gru Max capacity Traglast	9715 Kg / 2,70 m
	Raggio massimo di lavoro (versione 6S) Max outreach (6S version) Maximaler Arbeitsradius (Version 6S)	16,79 m
	Raggio massimo di lavoro con Jib idraulico (versione 6S+JIB 4S) Max outreach with Jib (version 6S+Jib 4S) Maximaler Arbeitsradius mit hydraulischem Jib (Version 6S+ Jib 4S)	26,35 m
	Altezza massima del braccio (versione 6S) Max hook height (6S version) Maximale Höhe des Armes (Version 6S)	20 m
	Altezza massima con Jib idraulico (versione 6S+JIB 4S) Max hook height with Jib (version 6S+Jib 4S) Maximale Höhe des Armes mit hydraulischem Jib (Version 4S)	29,2 m
	Angolo di rotazione-velocità Slewing angle-speed Schwenkbereich - Fahrgeschwindigkeit	Continua / 1,5 rpm Continuous / 1,5 rpm Endlos / 1,5 rpm
	Argano (optional) Winch (optional) Seilwinde (optional)	Tiro in diretta / First layer pull / Traglast 1-strangig Lunghezza fune / Rope length / Seillänge Velocità in tiro diretto / Speed in direct pull / Geschwindigkeit bei 1-Strang-Betrieb
	Radiocomando Radio remote control Fernsteuerung	Steady Can-Bus + Display a colori / Color display / Farbdisplay
	Limitatore di carico Stability control Lastmomentbegrenzer	Elettronico Electronic computergesteuert
	Stabilizzazione Stability system Abstützung	Infinita possibilità di posizionamento Dynamic stability area calculation Unendlich viele Möglichkeiten
	Peso degli elementi Weights Gewichte	Gru standard (Versione 6S) / Standard crane (6S Version)/ Standard Krane (Version6S) Jib (4S) Motore elettrico 15Kw/400 V / Electric motor 15 Kw/400V / Electromotor 15 Kw/400v Argano / Winch / Seilwinde Zavorra Mobile / Mobile ballast / Abnehmbare Ausgleichsgewichte Pattini in gomma / Rubber pads /Rollschienen in Gummi
	Trazione carro cingolato Crawler crane traction Antrieb des Raupenkrans	Trasmissione / Transmission / Antrieb Portata / Scope / Zulässige Traglast Pressione / Pressure / Druck Velocità / Speed / Fahrgeschwindigkeit Pendenza max / Max slope degree / Max. überwindbare Steigung Pressione al suolo / Max pressure on the ground / Bodendruck Larghezza pattino / Traks width / Breite des Läufer Carico max. stabilizzatore / Max. outrigger load / Maximale Belastung des Stabilisatoren
	Motore diesel Diesel engine Diesel Motor	Marca / Brand / Marke Modello / Model / Typ Potenza max / Max power / Max Leistung Coppia max / Max torque / Maximale Drehmoment Capacità serbatoio / Tank capacity / Tankinhalt

## DOTAZIONI STANDARD / STANDARD EQUIPMENT

- Radiocomando con display per ogni funzione del Carro, Stabilizzatori e Gru
- Rotazione continua
- Biella e forcella su ogni articolazione della gru
- Scambiatore di calore a velocità variabile
- Predisposizione per argano
- Predisposizione per il Jib
- Predisposizione per il cestello Porta operatore
- Sistema di controllo a variazione continua degli stabilizzatori
- Zavorre amovibili
- Avanzamento cingoli a 2 velocità
- Acceleratore dei giri motore
- N° 4 attacchi per il sollevamento
- N° 4 piastre amovibili per stabilizzatori
- Limitatore di carico elettronico
- Autodiagnosi
- Gru colore Giallo RAL 1007
- Carro colore RAL 9005
- Normativa di riferimento EN 12999.

- Radio remote control with display for crawler, chassis and crane function.
- Continuous rotation
- Links on all the crane articulations
- Variable speed oil fan cooler
- Predisposition for winch installation
- Predisposition for Jib Installation
- Predisposition for two man baskets installation
- Outriggers continuous variations
- Control system
- Removable ballast
- Two speed crawler translation
- Engine manual rpm increment
- N° 4 lifting connections
- N° 4 removable outriggers plates
- Electronic limiting device
- Auto diagnostic
- Crane color yellow RAL 1007
- Crawler color black RAL 9005
- According to EN12999.

- Fernbedienung mit Display für alle Funktionen des Rahmens (Fahrwerk), Stabilisatoren und Kran
- Endlos Umdrehung
- Kniehebelsystem an alle Kniepunkte
- Wärmeaustauscher mit variabler Geschwindigkeit
- Vorbereitung für Winde
- Vorbereitung für JIB
- Vorbereitung für Personen-Arbeitskorb
- Kontrollsystem mit fortlaufender Variation der Stabilisatoren
- abnehmbare Gegengewichte
- zweistufige Geschwindigkeit der Fahrwerk
- Manuelles Gaspedal
- N° 4 Befestigungspunkte für das Heben der Fahrwerk
- N°4 abnehmbare plattformen für die Stabilisatoren
- Elektronische Lasthaltventil
- Auto-Diagnose
- Farbe des Krans Gelb RAL 1007
- Farbe des Fahrwerks RAL 9005
- Übereinstimmung mit der Norm EN 12999.

## OPTIONAL

- Scanreco Can-Bus + Display
- Jib idraulico con operatività 200°
- Connessione idraulica Quick-Faster
- Linee idrauliche per accessori
- Prolunghe manuali
- Ganci Ribassati
- Attacchi ribassati per ventose
- Cestelli Porta operatori CE
- Argano a tiro diretto fino a 4 rinvii
- Ventose
- Fari di lavoro su braccio
- Fari di lavoro su carro
- Verricello di traino
- Generatore di corrente
- Cassette di grandi dimensioni amovibili
- Pianalino di carico amovibile
- Motore elettrico 15Kw/400 V trifase con inverter
- Piastre maggiorate per stabilizzatori
- Luci a LED per stabilizzatori
- Sovrappattini in gomma
- Pattini con gomma vulcanizzata antitraccia
- Olio biodegradabile
- Race
- DLC
- Sense.

- Scanreco Can-Bus + display
- Hydraulic Jib with opening up to 200°
- Quick-faster hydraulic connection
- Hydraulic line for accessorize
- Manual extensions
- Lowered hook connections
- Lowered connections for vacuum glass lifters
- Two man capacity baskets CE
- Direct pull winch up to 4th fall
- Vacuum glass lifters
- Working LED lightson the boom
- Working LED lightson the crawler
- Towing winch
- Electric generator
- Removable large box
- Removable loading flat bed
- Three phases electric engine15 Kw/400 V with inverter
- Bigger plates for outriggers
- LED lights for outriggers
- Rubber pads
- No marking rubber pads
- Green oil
- RACE
- DLC
- SENSE.

- Funkfernsteuerung Scanreco mit Can-Bus + display
- Hydraulischer JIB mit 200° Betrieb
- Hydraulische schnellverbindung
- Hydraulische Zusatzlinie für Zubehör
- Manuelle Verlängerungen
- Niedrige Lasthaken
- Niedrige Anbaustellen für Saugmembranen
- Arbeitskorb für Personen CE
- Seilwinde mit 4 Seil-Zug
- Saugteller (Mebranen)
- Arbeitscheinwerfer am Arm
- Arbeitscheinwerfer am Fahrwerk
- Seilwinde zum Schleppen
- Stromgenerator
- Grosse Werkzeugkästen abnehmbar
- Trittbrett abnehmbar
- Elektrischer Motor dreiphasig 15Kw/400V mit Inverter
- Grössere Plattformen für Stabilisatoren
- LED -Licht für Stabilisatoren
- Gummi-Pads
- Spurlos Gummi-Pads
- Biologisches abbaubares Öl
- Race
- DLC
- Sense.





Meno centimetri in altezza, lunghezza e larghezza ed un controllo millimetrico di avanzamento, consentono il raggiungimento di luoghi precedentemente preclusi a gru con tali prestazioni. Dimensioni record 4608X1650, H 2443 mm.

Less centimetres in height, length, width and a millimetric translation control, permit to reach places previously inaccessible to other cranes with same performance. Noteworthy sites: 4608X1650, H 2443 mm.

Die Niedrige Bauart und Dimensionen 4608X1650, H 2443 mm ermöglichen den Betrieb an Orten wo bisher keine konventionelle Kranfahrzeuge betrieben werden können.

BG LIFT, divisione "Gru compatte" di Brennero Gru, solida realtà produttiva nel settore del sollevamento. BG LIFT è un brand leader estremamente propositivo e fortemente focalizzato verso l'innovazione tecnologica e il design distintivo.

BG LIFT, A Brennero Gru "Compact Crane" division, solid production reality of the lifting branch. BG LIFT is a leader brand, extremely positive, ambitious and deeply focused on technologic innovation and peculiar design.

BG LIFT, Abteilung für "kompakte Kräne" von Brennero Gru, solide Produktgesellschaft im Kran - Sektor. BG LIFT, ist ein Leader-Brand und extrem Ausschau-haltend für Innovation in der Technologie und Design.

ADVINCERE.COM

**BG LIFT**  
by Brennero Gru 



**SILCOM NORTH UAB**  
www.silcomnorth.com  
hello@silcomnorth.com  
phone +370 672166  
Antakalnio g. 17, Vilnius 10312, Lithuania

R A N G E  
**CWE 315**