

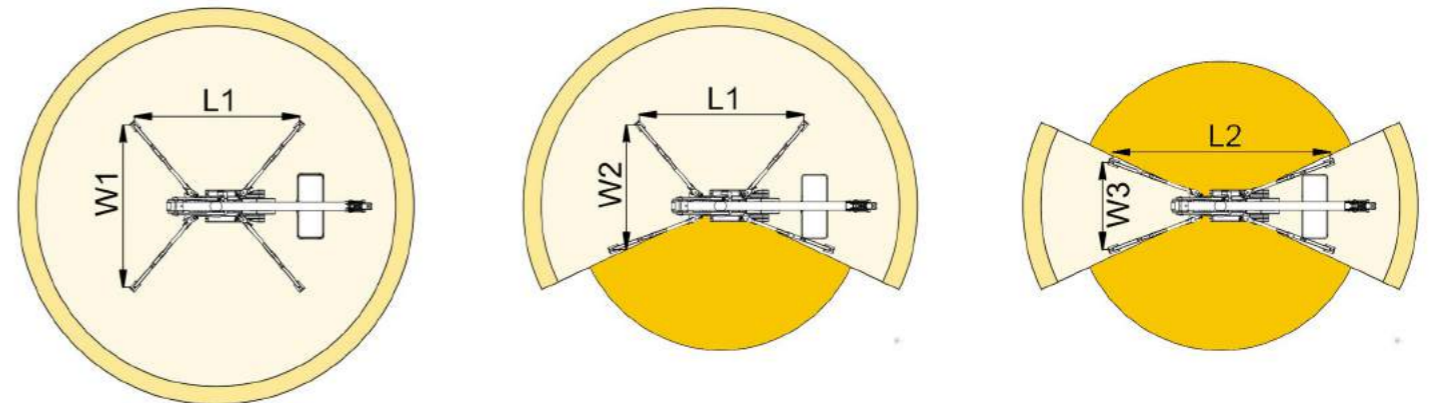

25 m ↑
13,2 m →
250 Kg 👤 👤

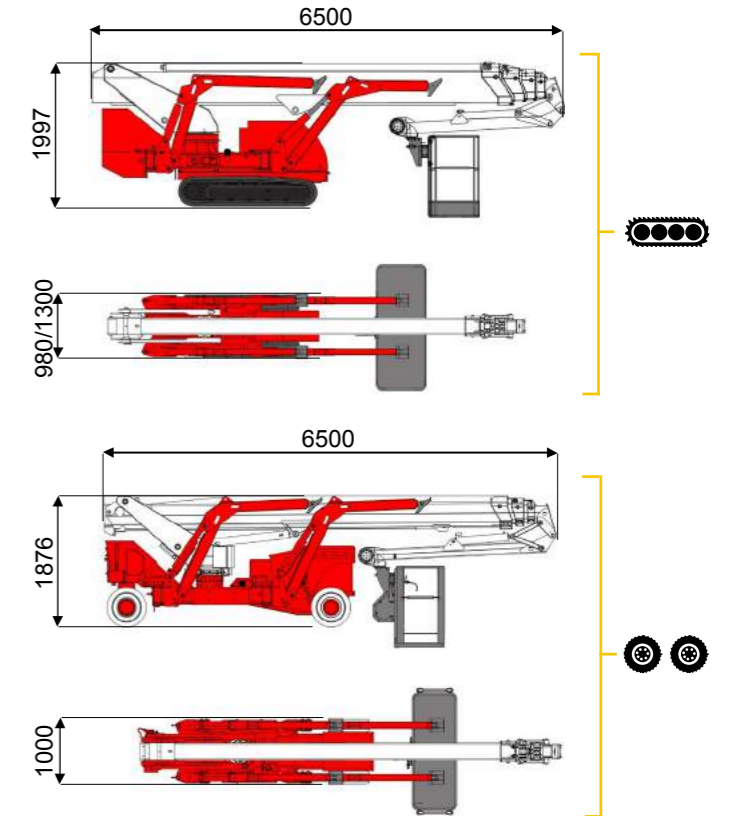
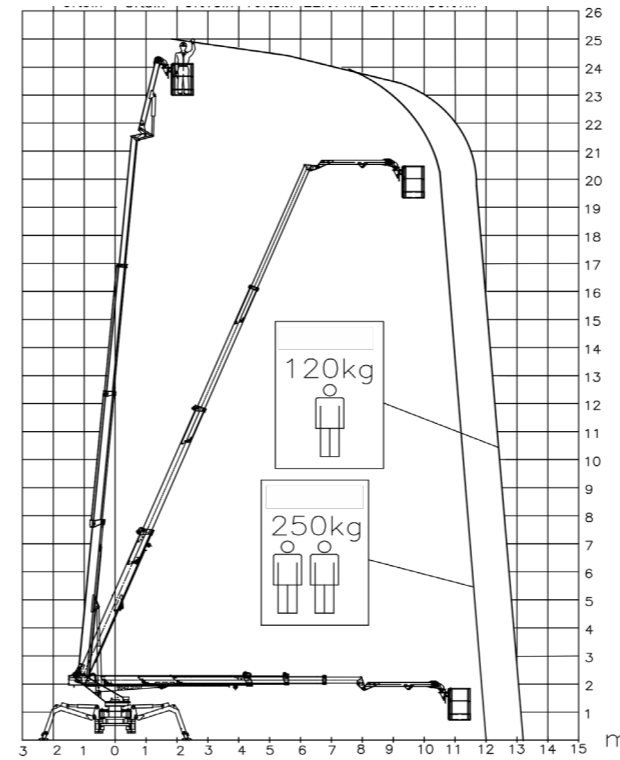

12 m	13,2 m	7,5 m	L1	L2	W1	W2	W3
250 kg	120 kg	120/250 kg	4971 mm	6542 mm	4853 mm	3732 mm	2610 mm

BI-ENERGY Diesel+AC															
TSJ 25/C		25 m	13,2 m	250 kg	170°	660°	180x70 cm	90°+80°	2,61-4,85 m	32%	36%	1 km/h	3950 kg	26 kN	1,64 kN/m ² 3,38 kN/m ²
TSJ 25/R		25 m	13,2 m	250 kg	170°	660°	180x70 cm	90°+80°	2,61-4,85 m	32%	19%	1 km/h	3950 kg	26 kN	1,64 kN/m ² 3,38 kN/m ²

Available version:

- BI-ENERGY (DIESEL+AC)
- ECO (DC+AC)
- HYBRID (DIESEL+DC)

Characteristics and technical data are informative only and subjected to change without notice.



Silcom North UAB
BALTIC OFFICIAL DELAER
hello@silcomnorth.com
Phone +370 67216691
www.silcomnorth.com
Antakalnio g. 17 Vilnius 10312
Lithuania
Company Code 30447488
VAT Code LT100010886914

COMPANY WITH
QUALITY SYSTEM
CERTIFIED BY DNV GL
= ISO 9001 =