

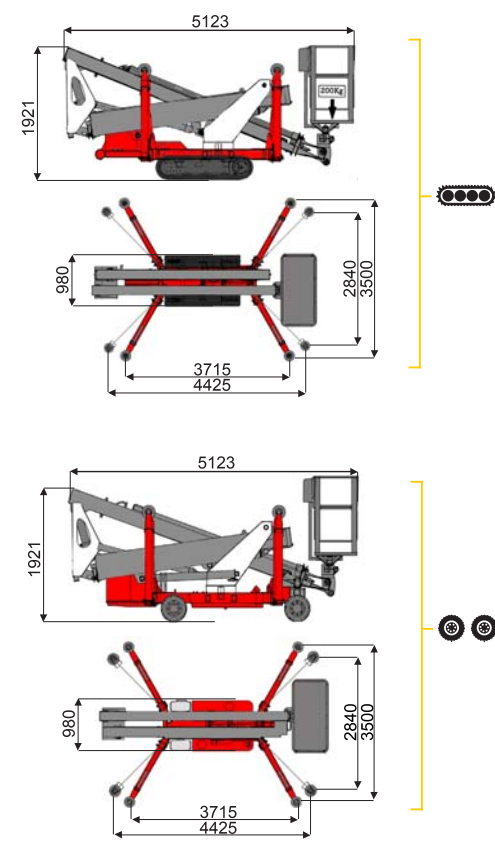

25 m ↑
10,6 m →
250 Kg 👤 👤

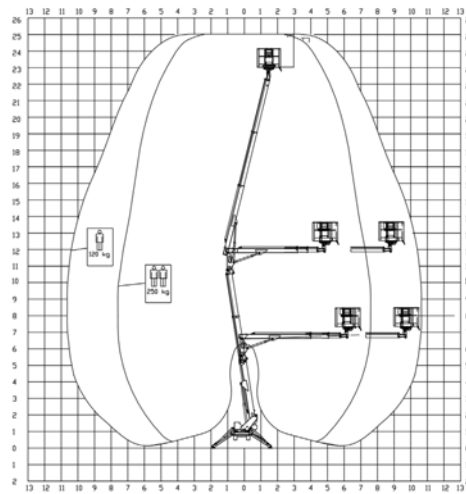

BI-ENERGY
Diesel+AC



TZX 250/C	25 m	10,6 m	250 kg	360°	140x70 cm	90°+90°	2,84-3,5 m	19%	23%	2,4 km/h	2660 kg	19,5 kN	2,05 kN/m ²	3,71 kN/m ²
TZX 250/R	25 m	10,6 m	250 kg	360°	140x70 cm	90°+90°	2,84-3,5 m	19%	21%	1,5 km/h	2660 kg	19,5 kN	2,05 kN/m ²	3,71 kN/m ²

Available version:

- BI-ENERGY (DIESEL+AC)
- ECO (DC+AC)

Characteristics and technical data are informative only and subjected to change without notice.

