

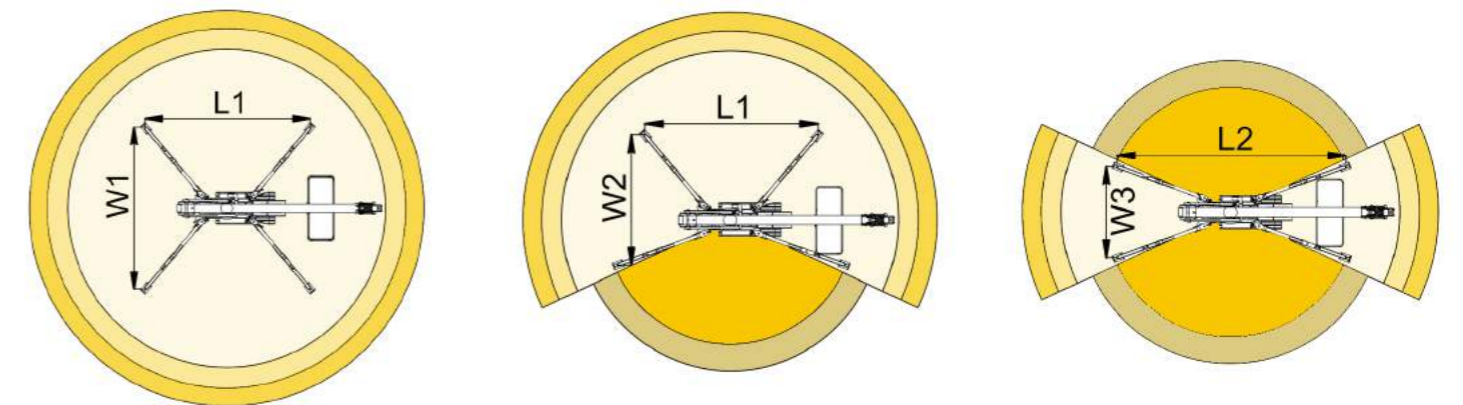

**52 m** ↑  
**19,5 m** →  
**400 Kg\*** 👤👤👤

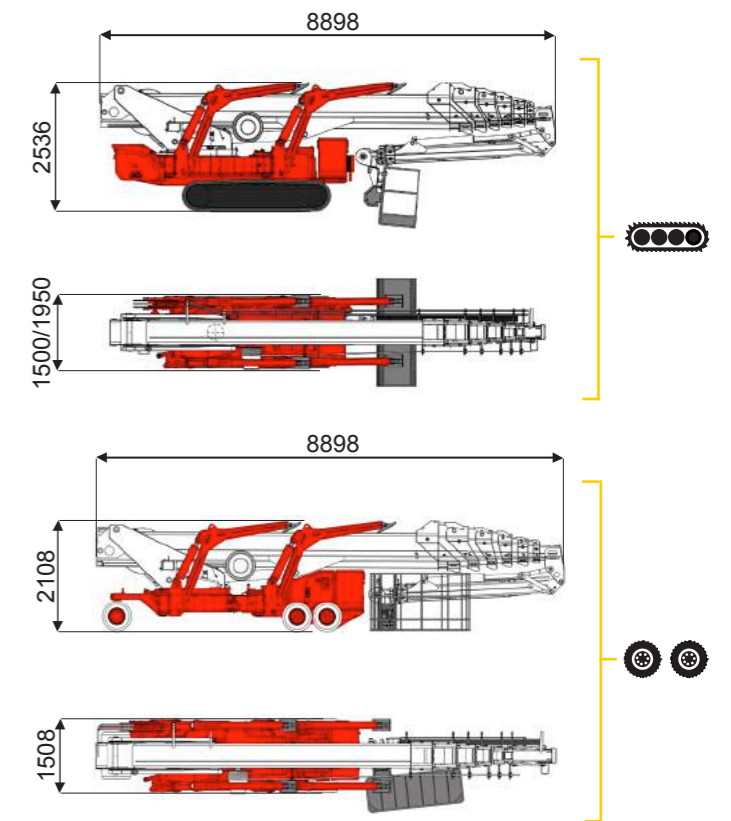
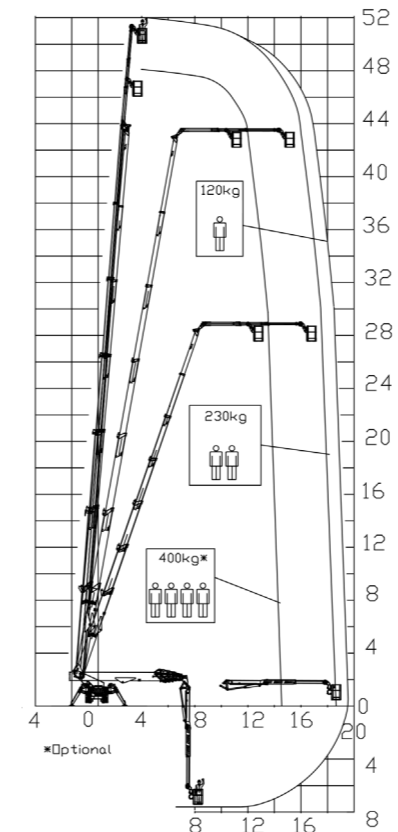

16,8 m	18,5 m	19,5 m	14,8 m	16,5 m	L1	L2	W1	W2	W3
400 kg*	230 kg	120 kg	400 kg*	120/230 kg	6460 mm	7190 mm	5170 mm	4655 mm	4130 mm

**BI-ENERGY**  
Diesel+AC

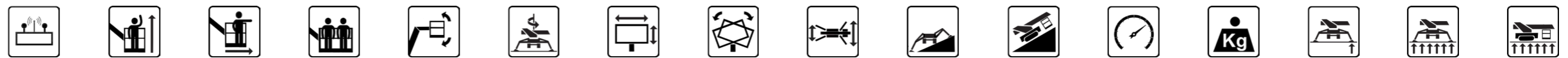

<b>XTJ 52+/C</b>	🚧	52 m	19,5 m	400 kg*	170°	660°	240x70 cm	90°+80°	4,13-5,17 m	16%	42%	1 km/h	14000 kg	80 kN	4,19 kN/m <sup>2</sup>	6,56 kN/m <sup>2</sup>
<b>XTJ 52+/R</b>	🚧	52 m	19,5 m	400 kg*	170°	660°	240x70 cm	90°+80°	4,13-5,17 m	16%	21%	1 km/h	13000 kg	80 kN	3,89 kN/m <sup>2</sup>	6,09 kN/m <sup>2</sup>

Available version:

- BI-ENERGY (DIESEL+AC)
- ECO (DC+AC)
- HYBRID (DIESEL+DC)

Characteristics and technical data are informative only and subjected to change without notice.



Silcom North UAB  
BALTIC OFFICIAL DELAER  
hello@silcomnorth.com  
Phone +370 67216691  
www.silcomnorth.com  
Antakalnio g. 17 Vilnius 10312  
**Lithuania**  
Company Code 30447488  
VAT Code LT100010886914

COMPANY WITH  
QUALITY SYSTEM  
CERTIFIED BY DNV GL  
= ISO 9001 =