

Righetti

smart vacuum lifters

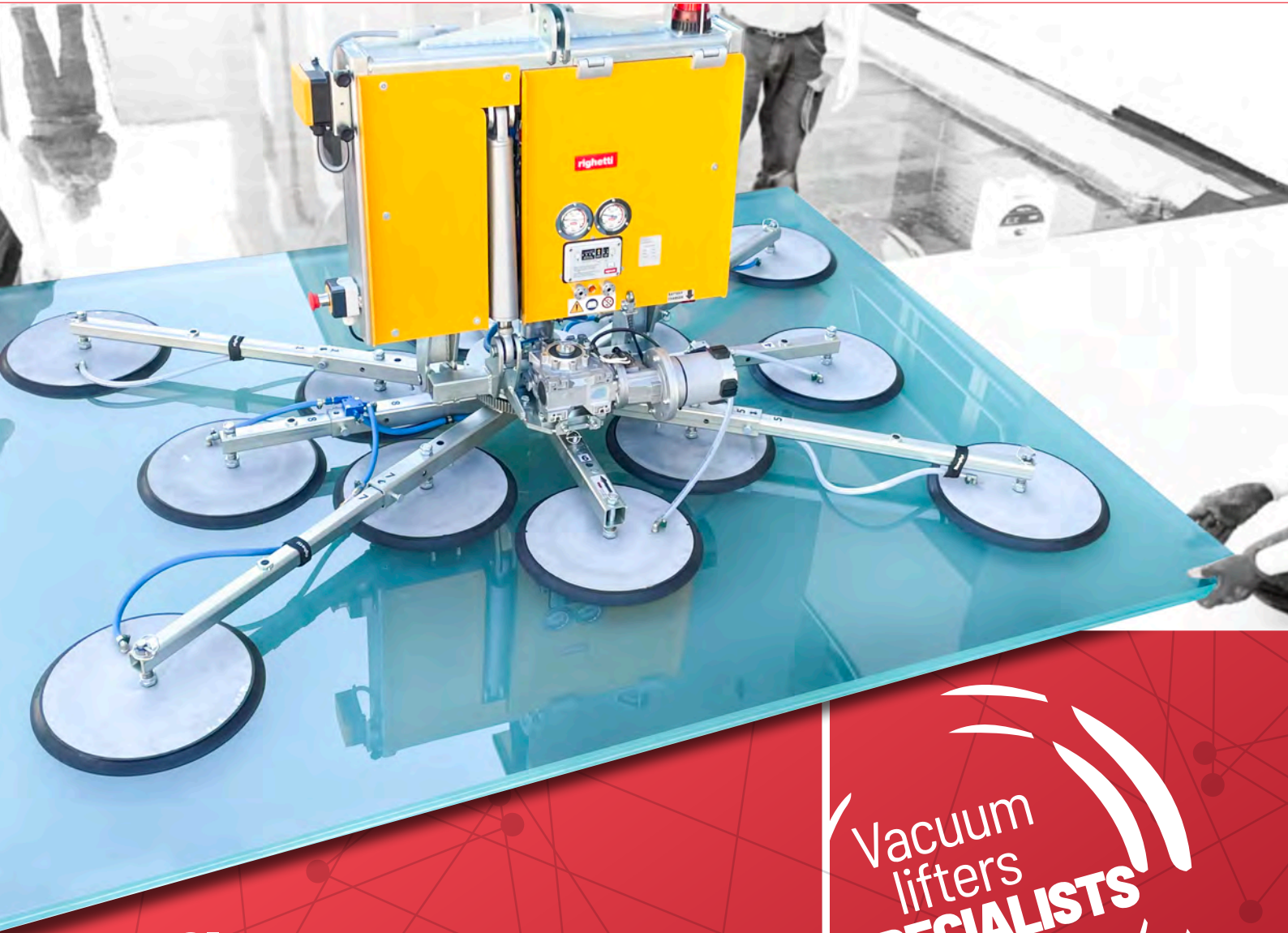

Glass vacuum lifters

Vacuum
lifters
SPECIALISTS

People Behind Vacuum
Lifting Technology Excellence

Italian craftsmanship
and smart technology:
your vacuum lifter
for every application



Specialists in Vacuum Lifters

For over 20 years we've been working combining typical Italian handcraft creativity with the a technological and industrial advancement. The perfect mix of these two views has led to the conception and design of a broad range of products that we can introduce you to, both from the catalog and custom .

We like solutions that work, that get there by the requested deadlines, and that come with rapid, competent service catered to the customer.

We love getting anywhere with our lifters, even on a global scale. The experience we've gathered on the field helps us give you accurate answers, no matter where you are.

The geographic area isn't a limit anymore, but a way to make new long-lasting relationships. Because buying a Righetti means finding a reliable and efficient ally for optimizing your productivity.

From hands experienced in working the metal, from a precise and industrial organisation: this is where your vacuum lifter takes shape.



**Design
and production**



**More than
500 models**



**3500 m²
warehouse**



**International
shipments**

Why using vacuum lifters?

For some time now, Vacuum Lifters have been a valuable aid in handling and lifting glass panes both on construction site and in production environments.



Why choosing a Righetti?

Top technology, user-friendliness, comfortable to use, safety. All in one machine.

What are the pros?

Righetti has designed vacuum lifters capable of automating the work and reducing the times of production.

- Make work easier, safer and faster
- Reduce handling times and labor costs
- Immediate suction of the load
- Wide choice of models and possibilities of customization

How does it work?

- 1 Power supply:** electric, batteries or compressed air
- 2 Safety devices:** constant monitoring vacuum level, plus visual and acoustic warning systems
- 3 Suction pads:** gaskets specific for glass
- 4 Vacuum circuit:** tested reliability and safety to respect EN13155 standard

Righetti Service: your assistance

We support you via phone and video to never stop your work. We are by your side with fast and precise assistance directly from those who built your lifter.

Fast production

Artisan heart and industrial production: the perfect union to get you the vacuum lifter you choose in the shortest time possible.

Safety above all else

Both the worker and the load are always taken as the focal points during the design and construction of the lifters. Rely on us.

Worldwide shipping

Our vacuum lifters reach everywhere, even to you. Experience and relationships with customers throughout the world allow us to ship anywhere, in established times.

Righetti
smart vacuum lifters

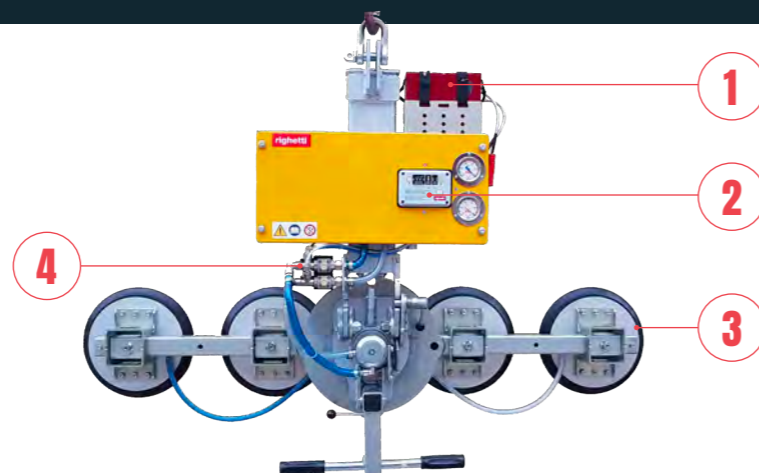

Specialists in vacuum lifters not just talk, but real advantages for your job

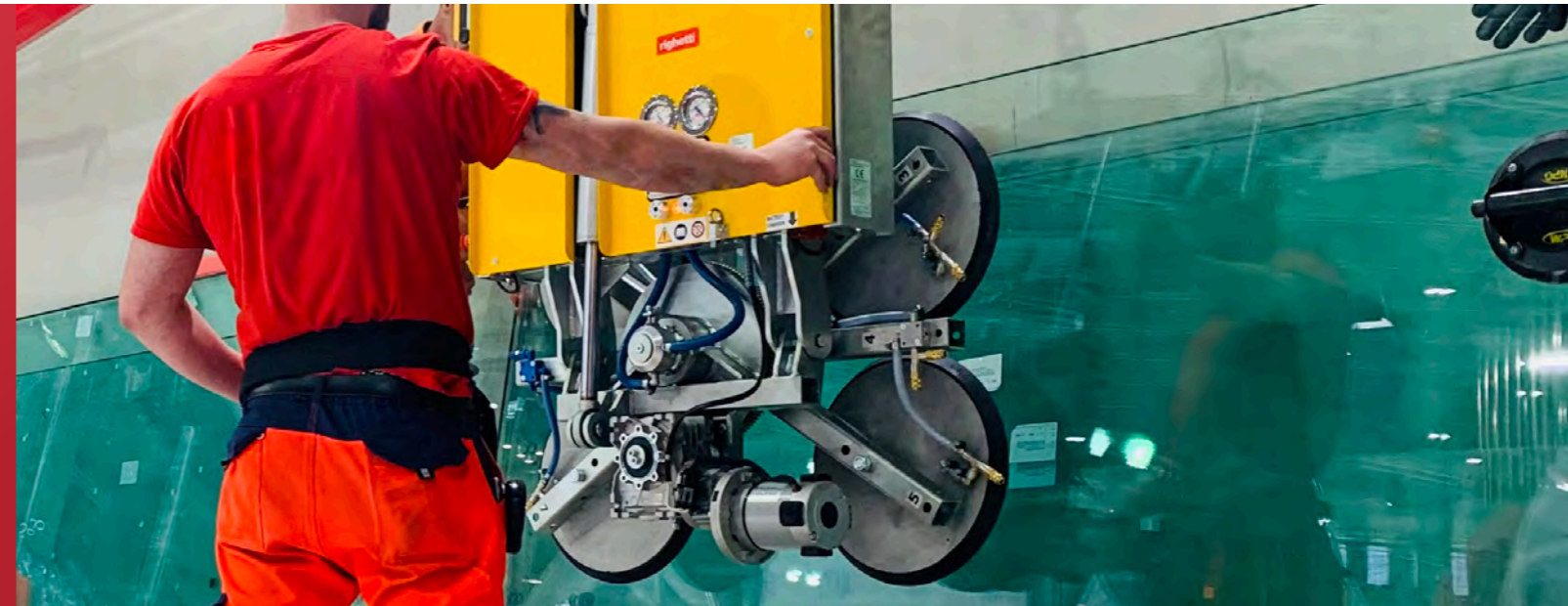

1

Absolute focus on safety

The load and the operator are always protected with Righetti systems

Our vacuum lifters come complete with systems for monitoring the vacuum to guarantee safety while lifting the load. The dual acoustic and visual alarm warns the operator if there isn't enough vacuum to lift the load safely. The ample vacuum reservoir on the lifter guarantees a hold on the load even if there is a malfunction or the power gets cut off.

3

Lifters with sturdy structures for professional use

Compact but robust structures to last over time

Righetti's vacuum lifters have a structure that is sturdy, yet compact and streamlined. Solid structures guarantee the stability of the load and the lifter itself, even with large weights and sizes.

2

Suitable to any size load

The modular configurations let you exploit the lifters on any size

Our R&D department designed the glass vacuum lifters contemplating the more common needs of handling glass panes. Our lifters have repositionable suction pads and extension arms to create several configurations and adapt to different sizes and shapes.

With just one machine you will be more versatile on the job.

4

Gripping speed and instant suction

The lifters' gripping speed will get the job done faster

Vacuum lifters become handy when you need to get the job done faster. It will also help you in lowering labor costs.

The technology developed by Righetti make grabbing the load extremely faster. This is because our R&D has designed specific suction pads to guarantee an optimal hold and a fast adhesion to the load.

5

Suction pads for all the cases

Flexibility is the key and we work for proving it to you

Righetti has widen up its range of suction pads and accessories in order to give you wide flexibility. Our suction pads may be interchanged to lift standard, frosted or curved glass with just one single vacuum lifter. And if you need to handle also window frames, we have the right support for creating distance between the frame and the glass.

6

A solution for all your needs

We have a vast array of vacuum lifters for lifting glass. We have developed solutions with batteries for construction sites and outdoor usage, while we have created electrically or compressed-air operated models for production and indoor use.

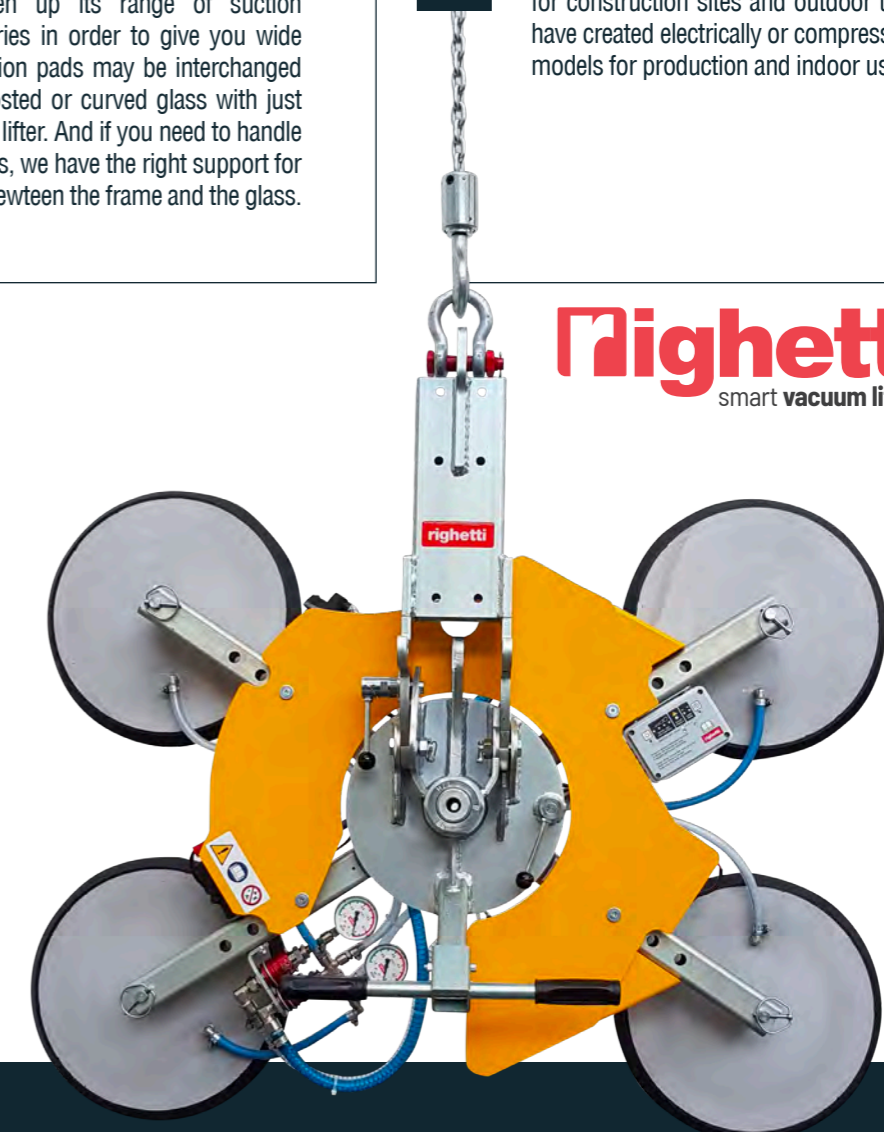

Righetti
smart vacuum lifters

Table of contents

11

CONSTRUCTION SITES

Battery powered with manual movements

VB4 RCMBM	16
VB4 PRO	17
VB4+4	18
VB4+4 X/XL	19
VB4T4	20
VB4T4 PRO	21
VB2 / VB4L	24
VB6 / VB8	25
VB6+4 / VB8+4	26
GLAXTER	27
GL-VB2 / GL-VB4L / GL-VB4TR	28
VB-SP2 / VB-SP3	29
SLIM	30

Battery powered with electric movements

VB4 RCEBE	36
VB4 RCEBE PRO	37
VB4+4 RCEBE	38
VB4+4 RCEBE X/XL	39
VB4L RCEBE / VB6 RCEBE	40
VB8 RCEBE / VB6+4 RCEBE	41
GLE 4+8	42
GLE2200	44
GLE3000	45

Battery powered for curved glass

VB4-C / VB-CG	50
VB-CGE	51

55

PRODUCTION

Electrically powered with manual movements

VEB2 RCMBM / VEB4L RCMBM	58
VEB4 RCMBM / VEB4 RCMBM PRO	59
VEB6 RCMBM / VEB8 RCMBM	60
VEB4+4 RCMBM / VEB4+4 RCMBM XL	61

Electrically powered with electric movements

VEB2 RCEBE / VEB4L RCEBE	64
VEB4 RCEBE / VEB4X RCEBE	65
VEB6 RCEBE / VEB8 RCEBE	66
VEB4+4 RCEBE / VEB4+4 RCEBE XL	67

Compressed-air powered

VA-RCM / VA-RCMBM	70
VA-RCMBP / VA4 RCMBP-R	71
VA-RP / VA2+2T-RP/TH	72
VA-RPBP / VA-BP	73
R1	74

Vertically fixed frame

VEB-FV/VA-FV / VEB-L-FV	78
OPTIONAL	79



Righetti
smart vacuum lifters

Glass vacuum lifters
specifically for

**construction
sites**

Righetti has a wide range of glass vacuum lifters specific for construction site.

These vacuum lifters are specifically designed for working outdoors, as they are equipped with a dual vacuum circuit and safety systems to warn you about potential dangers. Moreover, they are operated by high-capacity batteries, which can be easily removed and recharged.

In the models hereby presented, all the movements (tilt and rotation) are done manually.

VACUUM CONTROL UNIT

An on-board computer (PLC) that constantly controls the vacuum lifter and its safety components, besides executing a self-diagnostics to guarantee the well-functioning. It is also equipped with:

- **ACOUSTIC AND VISUAL ALARMS** to warn the worker about possible dangers
- **BATTERIES STATUS INDICATOR** to keep the batteries level under control
- **A BUILT-IN ECONOMIZER** to lengthen batteries life

LOWERED HOOK CONNECTION

for installing glass panes even in the toughest spots

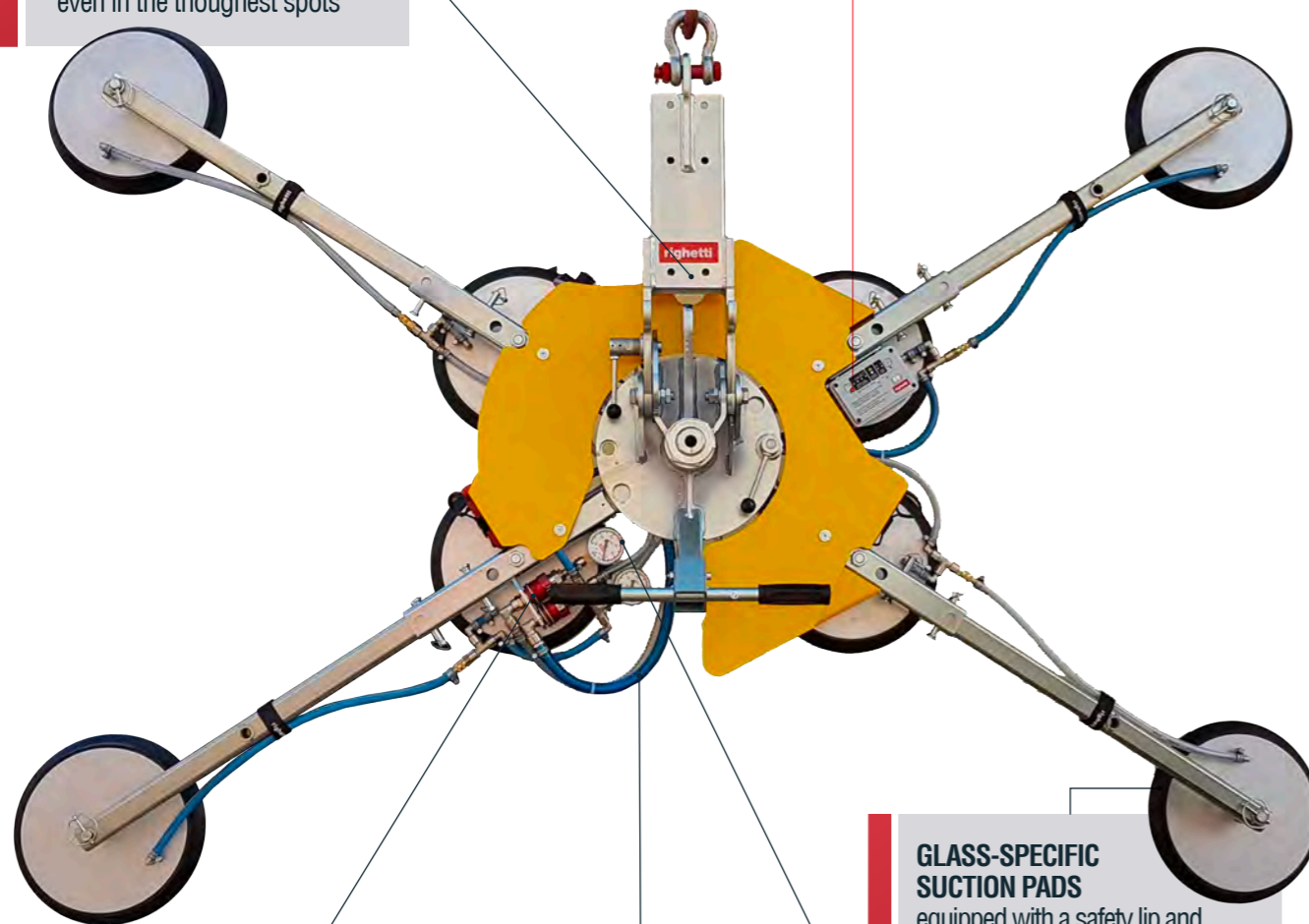

GLASS-SPECIFIC SUCTION PADS

equipped with a safety lip and rings, plus double spring system to compensate the flexion of the load

DUAL-ACTION OFF COMMAND

to safely control load suction and release

DUAL VACUUM CIRCUIT

to guarantee safety in compliance with standard EN13155

DUAL VACUUM GAUGES

with color scale to visually monitor the vacuum level in the circuit

Glass vacuum lifters

battery powered with manual movements



Batteries operated



Manual 360° rotation



Manual tilt 0-90°

Righetti
smart vacuum lifters

6 reasons for choosing our VB4 series

1 Glass installation even in height-limited spaces

Complicated below-the-hook heights will no longer be a problem thanks to the lowered hook connection that Righetti vacuum lifters mount as standard (only in manual movements lifters).

In case a worker needs to pass below an existing structure within certain height limits, it is possible to reduce the below-the-hook height by lowering the lifting arm and using the lowered hook connection.

2 Removable and easily replaceable batteries

Righetti batteries are quick to replace and easy to recharge.

Designed for your safety, the charge level will always be indicated by the indicator light. And to never stop your construction site, you can have an extra kit and separate charger included: while you're working, you can always have a pair of batteries charging.

3 Instant suction for faster work

Vacuum lifters' job is to make your workload easy and faster.

Because of this, suction pads are designed and created to perfectly adapt to the surface of the load.

At activation of suction, our special vacuum circuit guarantees immediate aspiration of the glass panels. Within few seconds you can safely handle and lift the load.

4 Controlled inclination system

Do you find challenging to manually tilt your vacuum lifter? Righetti has your back. We have studied, designed, created and patented a mechanism that gives you full control of the manual tilt in both directions (0-90°). Just rotate the handwheel located in the center of the vacuum lifter to adjust its inclination according to your needs. Fast, easy and safe to use: opt for controlled inclination system to simplify your job.

5 Modular frame

What makes VB4 series truly appealing to workers is its flexibility and modularity.

Starting from the basic VB4, equipped with four repositionable suction pads, you can upgrade up to the most modular vacuum lifter VB4+4 XL. Using the latter lifter to handle your glass panes, you can create more than 8 configurations to adjust to all your needs: the size and shape of glass panes won't bother you anymore.

6 Low vacuum dispersion suction pads

At Righetti, we accurately study every detail of our vacuum lifters: suction pads are one of those aspects on which we concentrated much energy to come up with the perfect solution.

Our suction pads gaskets are sealed with safety lip and rings for extra hold. Moreover, suction pads have spring system to best compensate the flexion of glass sheets.

Safety systems for the load and the workers

For safely working on construction sites in compliance with EN13155, our vacuum lifters are equipped with a high-performing control unit that will warn you in case of any dangerous situations.

Moreover, the whole VB4 series has a dual vacuum circuit and reservoir to guarantee the hold of the load in case of malfunctions.

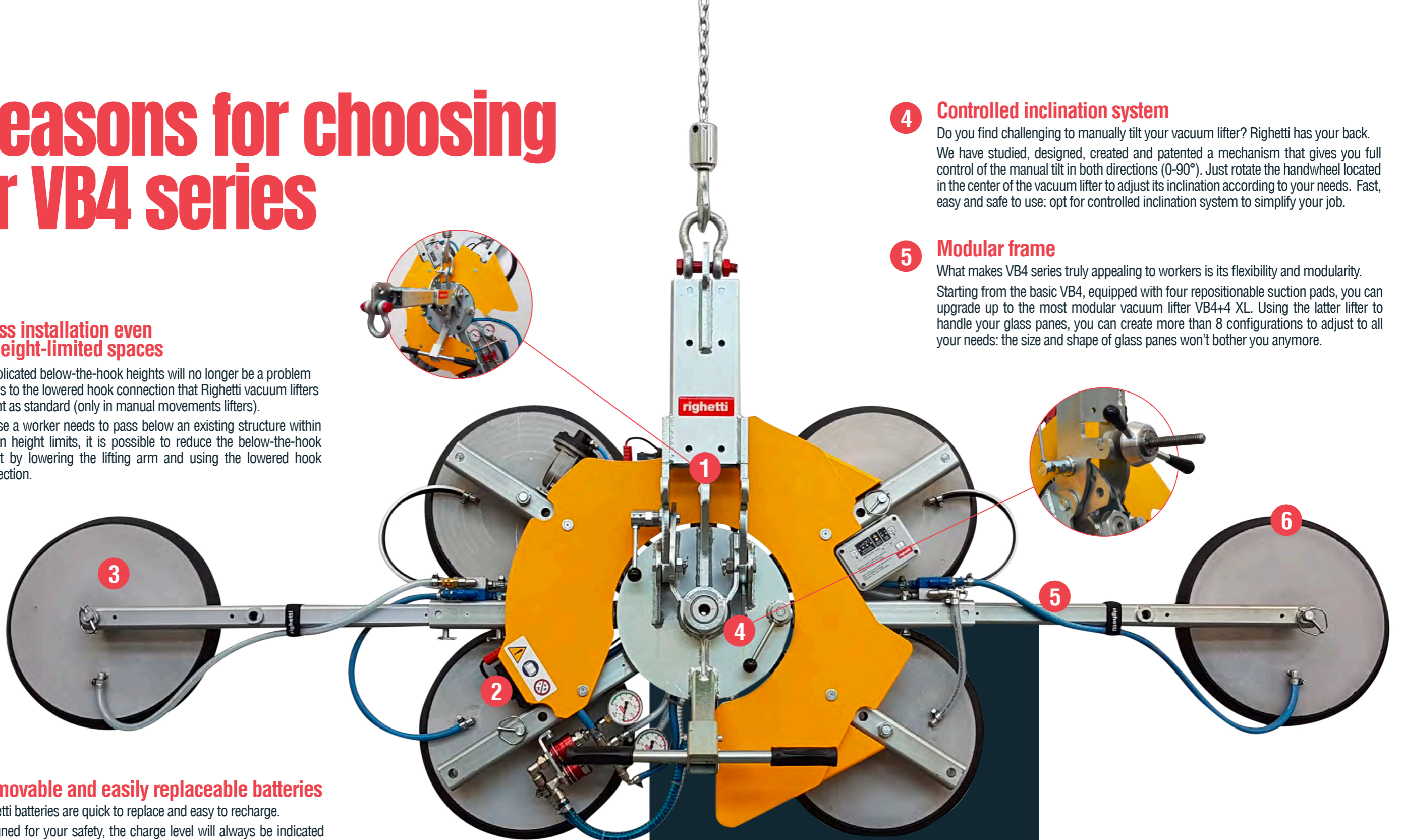

VB4 RCMBM

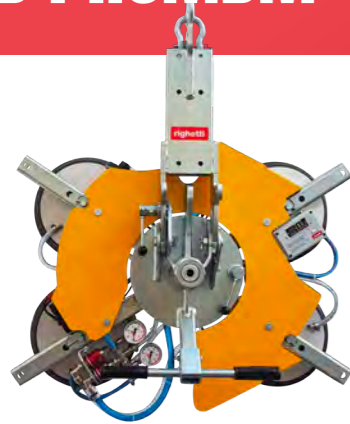

Batteries powered



Manual tilt 0-90°



Manual rotation 360°



4 suction pads



Dual vacuum circuit



Wireless radio remote control as optional

VB4 is a glass vacuum lifter equipped with 4 adjustable suction pads to create two configurations which make it possible to handle small and medium size panes. This model is powered by rechargeable and removable batteries to never interrupt your work on construction site. Tilting system and continuous rotation are done manually. In accordance with EN13115 laws, VB4 is equipped with a dual vacuum circuit, plus visual and acoustic safety alarms.

VB4 RCMBM 400kg

Kg max 400

Suction pads		Capacity Kg	Product code	Configurations	Suction pads spread
No.	Ø mm				mm
4	310	400	VB4 RCMBM	X1 * Y1	863 x 666
				X2 * Y2	1166 x 861

VB4 RCMBM d4 600kg

Kg max 600

Suction pads		Capacity Kg	Product code	Configurations	Suction pads spread
No.	Ø mm				mm
4	390	600	VB4 RCMBM d4	X1 * Y1	1019 x 795
				X2 * Y2	1246 x 941

Technical drawings

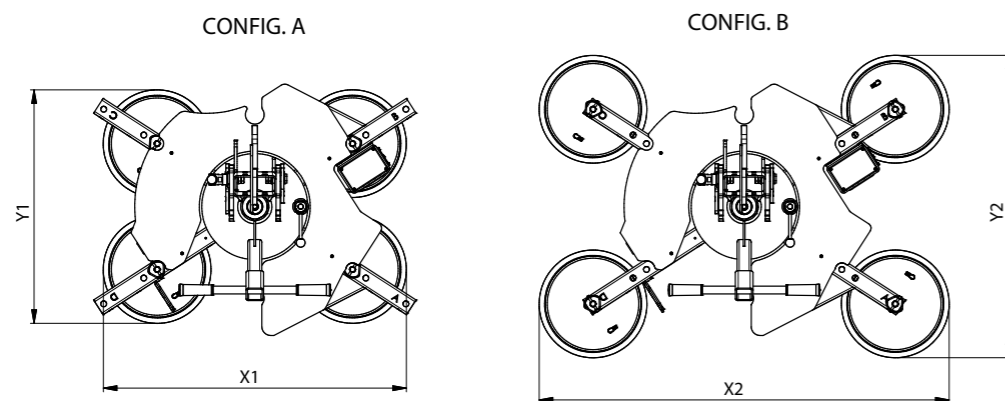

VB4 PRO

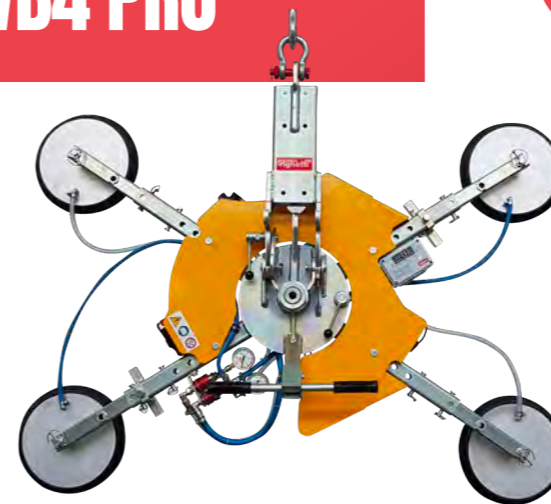

Batteries powered



Manual tilt 0-90°



Manual rotation 360°



4 suction pads



Dual vacuum circuit



Wireless radio remote control as optional

VB4 PRO is the upgraded glass vacuum lifter of the standard VB4. Its 4 adjustable suction pads allow you to create several configurations for a safe handling of small glass, large panes, and long and narrow panes. Thanks to its modularity, VB4 PRO gives you huge flexibility for working on construction site. Moreover, it is equipped with rechargeable and removable batteries, manual tilt, manual continuous rotation, safety devices and a dual vacuum circuit.

VB4 RCMBM PRO 400 kg

Kg max 400

Suction pads		Capacity Kg	Product code	Configurations	Suction pads spread
No.	Ø mm				mm
4	310	400	VB4 RCMBM PRO	X1 * Y1	863 x 666
				X2 * Y2	1166 x 861
				X3 * Y3	1535 X 1100
				X4 * Y4	1770 X 310

VB4 RCMBM d4 PRO 600kg

Kg max 600

Suction pads		Capacity Kg	Product code	Configurations	Suction pads spread
No.	Ø mm				mm
4	390	600	VB4 RCMBM d4 PRO	X1 * Y1	1019 x 795
				X2 * Y2	1246 x 941
				X3 * Y3	1630 x 1190
				X4 * Y4	1870 x 390

Technical drawings

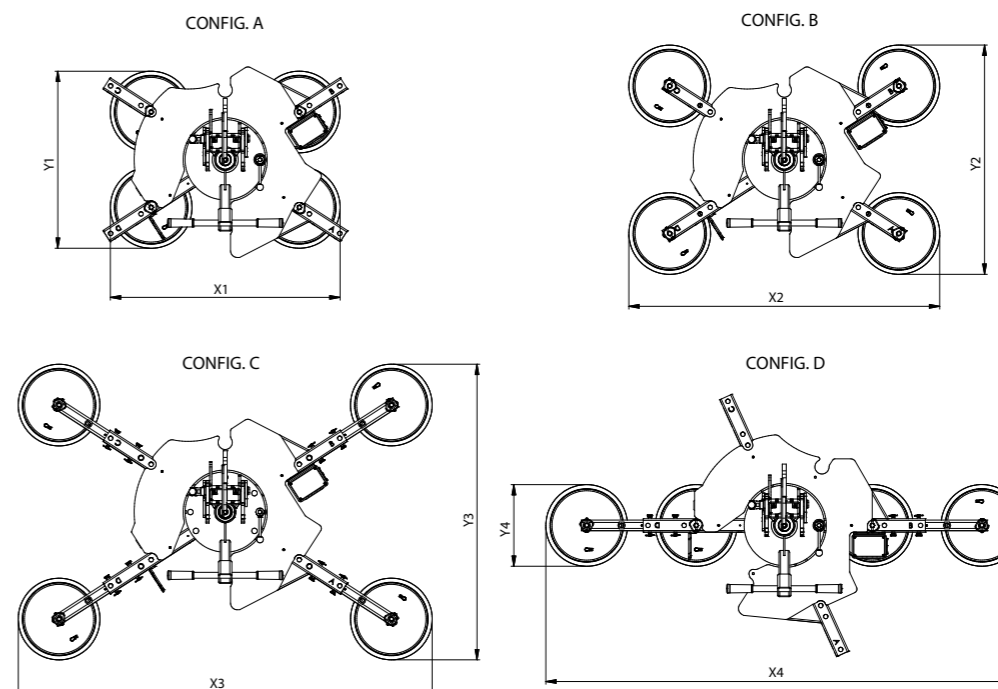

VB4+4

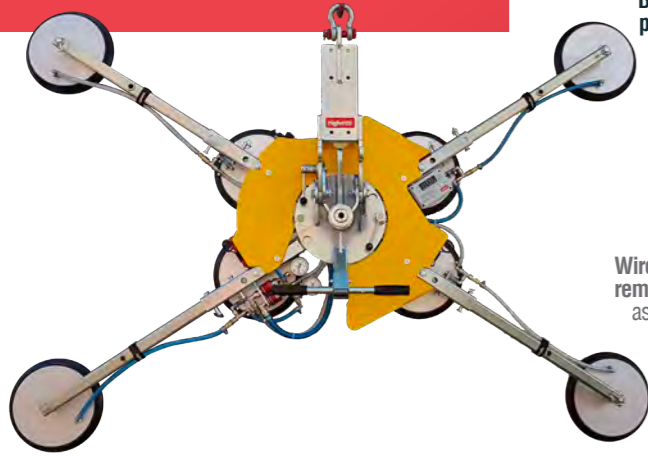

Wireless radio remote control as optional

VB4+4 is a glass vacuum lifter that offers you wide flexibility. This model is equipped with 4 fixed suction pads, plus 4 external suction pads placed on removable extension arms. By adding or removing the arms, you can increase or decrease the lifting capacity and pad spread of the vacuum lifter.

VB4+4 RCMBM 800kg

Kg max 800

Suction pads		Capacity Kg	Product code	Configurations			Suction pads spread
No.	Ø mm			Pads in use	Conf. capacity	Dimensions	mm
8	310	800	VB4+4 RCMBM	4	400	X1 * Y1	863 x 666
				4+4	800	X2 * Y2	1700 x 1210
				4+4	800	X3 * Y3	2145 x 1488
				4+4	800	X3 * Y3	2145 x 1488

VB4+4 RCMBM d4 1200kg

Kg max 1200

Suction pads		Capacity Kg	Product code	Configurations			Suction pads spread
No.	Ø mm			Pads in use	Conf. capacity	Dimensions	mm
8	390	1200	VB4+4 RCMBM d4	4	600	X1 * Y1	1019 x 795
				4+4	1200	X2 * Y2	1780 x 1290
				4+4	1200	X3 * Y3	2248 x 1596
				4+4	1200	X3 * Y3	2248 x 1596

Technical drawings

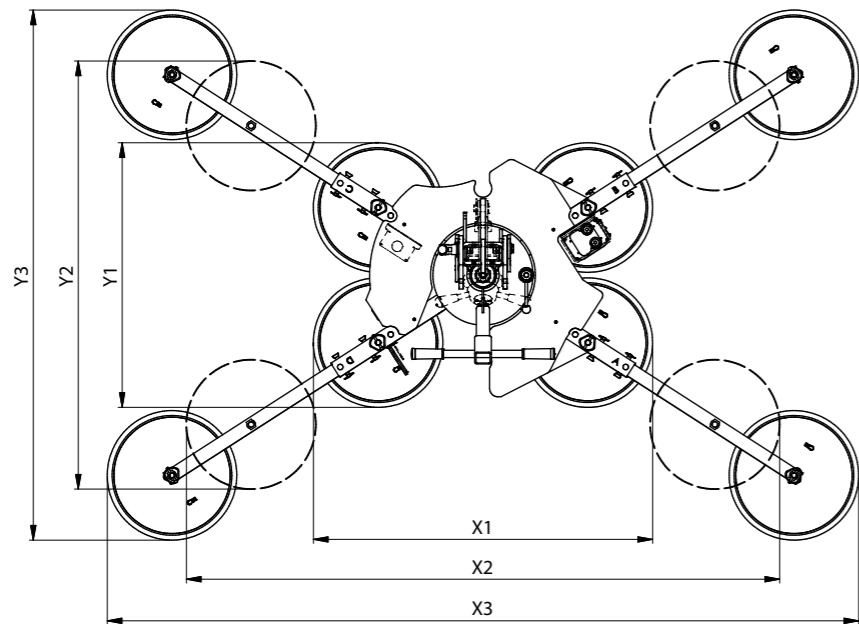

VB4+4 X/XL

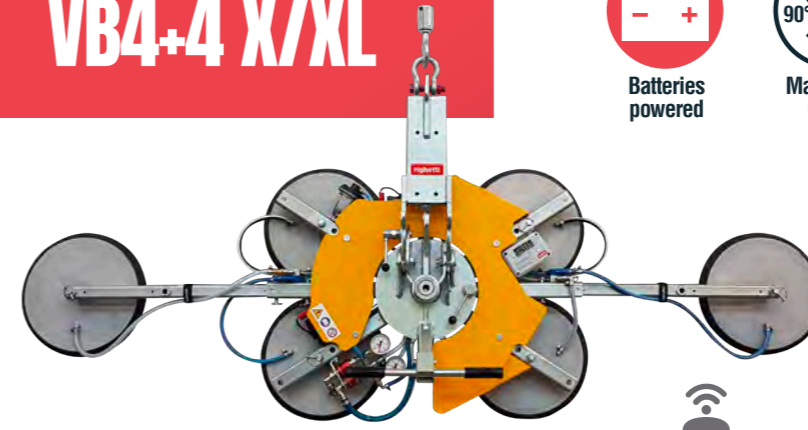

Wireless radio remote control as optional

VB4+4 X/XL is the upgraded version of VB4+4. What makes this model extremely interesting is the wide range of configurations and alignments that can be created. This model is equipped with 8 suction pads and 4 extension arms, thus giving the operator the power to easily change configurations. By adding or removing the suction pads, you can increase or decrease the lifting capacity and pad spread of the vacuum lifter.

VB4+4 RCMBM X / XL 800kg

Kg max 800

Suction pads		Capacity Kg	Product code	Configurations			Suction pads spread
No.	Ø mm			Pads in use	Conf. capacity	Dimensions	mm
8	310	800	VB4+4 RCMBM X	4	400	X1 * Y1	863 x 666
				4+4	800	X2 * Y2	1700 x 1210
				4+4	800	X3 * Y3	2145 x 1488
				4+2	600	X4 * Y4	2430 x 715
			VB4+4 RCMBM XL	4 (line)	400	X5 * Y5	2530 x 310
				2	200	X6 * Y5	970 x 310
				4 (line)	400	X5 * Y5	2530 x 310
				2	200	X6 * Y5	970 x 310

VB4+4 RCMBM d4 X / XL 1200kg

Kg max 1200

Suction pads		Capacity Kg	Product code	Configurations			Suction pads spread
No.	Ø mm			Pads in use	Conf. capacity	Dimensions	mm
8	390	1200	VB4+4 RCMBM d4 X	4	600	X1 * Y1	1019 x 795
				4+4	1200	X2 * Y2	1780 x 1290
				4+4	1200	X3 * Y3	2248 x 1596
				4+2	900	X4 * Y4	2510 x 800
			VB4+4 RCMBM d4 XL	4 (line)	600	X5 * Y5	2610 x 390
				2	300	X6 * Y5	1150 x 390
				4 (line)	600	X5 * Y5	2610 x 390
				2	300	X6 * Y5	1150 x 390

Technical drawings

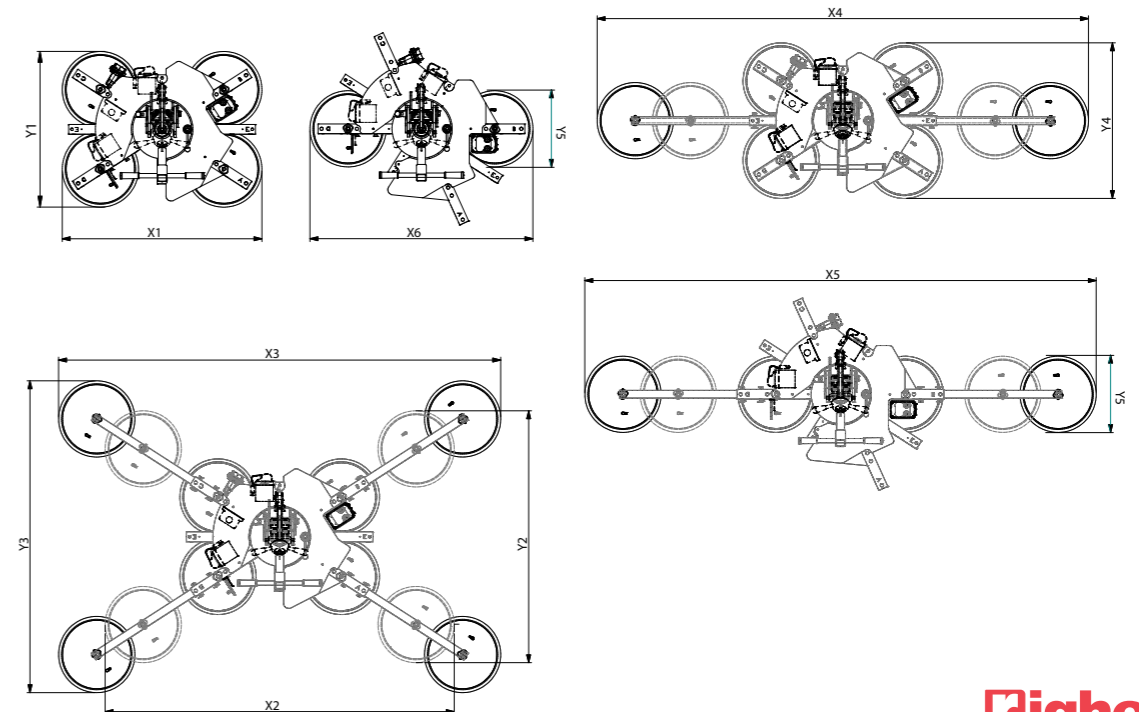

VBT4

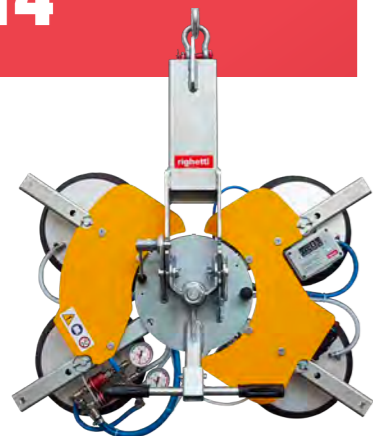

Batteries powered



Manual tilt 0-90°



Manual rotation 360°



4 suction pads



Dual vacuum circuit

VBT4 is a glass vacuum lifter equipped with 4 adjustable suction pads to create two configurations which make it possible to handle small and medium size panes. This model is powered by a single rechargeable and replaceable battery. The peculiarity of this model is its lightweight (only 48kg), which make it perfect for small lifting systems and trolleys.

VBT4 400kg

Kg max 400

Suction pads		Capacity Kg	Product code	Controlled inclination device connection	Configurations	Suction pads spread
No.	Ø mm					mm
4	310	400	VBT4	No (*)	X1 * Y1	863 x 666
					X2 * Y2	1166 x 861

(*) For models with controlled tilt device connection included, choose VBT4-CT

Technical drawings

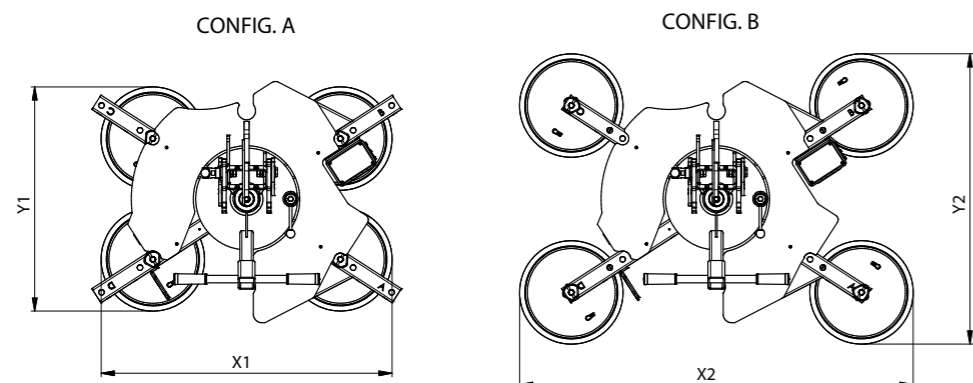

VBT4 PRO



Batteries powered



Manual tilt 0-90°



Manual rotation 360°



4 suction pads



Dual vacuum circuit

VBT4 PRO is the upgraded glass vacuum lifter of the standard VBT4.

Its 4 adjustable suction pads allow you to create several configurations for a safe handling of small glass, large panes, and long and narrow glass. Thanks to its modularity, VBT4 PRO gives you huge flexibility for working on construction site. The peculiarity of this model is its lightweight, which make it perfect for small lifting systems and trolleys.

VBT4 PRO 400kg

Kg max 400

Suction pads		Capacity Kg	Product code	Controlled inclination device connection	Configurations	Suction pads spread
No.	Ø mm					mm
4	310	400	VBT4 PRO	No (*)	X1 * Y1	863 x 666
					X2 * Y2	1166 x 861
					X3 * Y3	1535 X 1100
					X4 * Y4	1770 X 310

(*) For models with controlled tilt device connection included, choose VBT4-CT PRO

Technical drawings

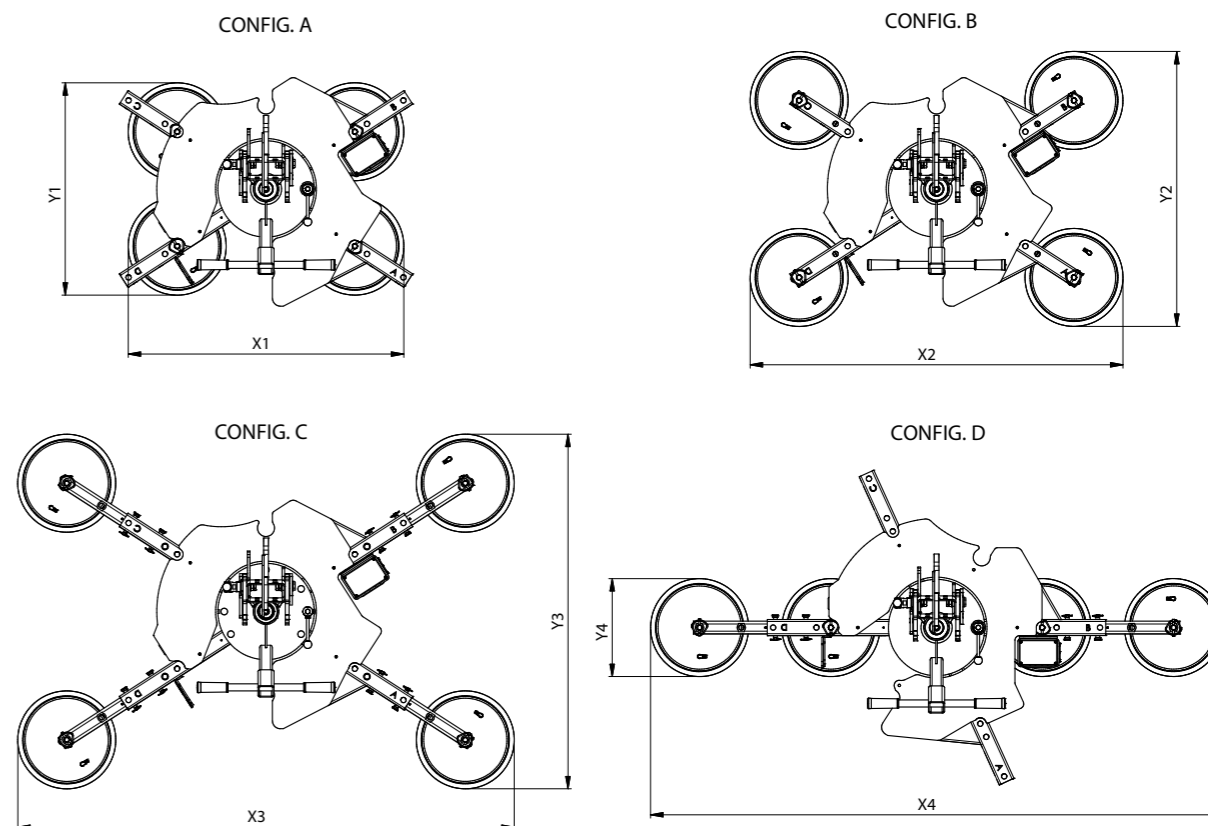

Model's comparison

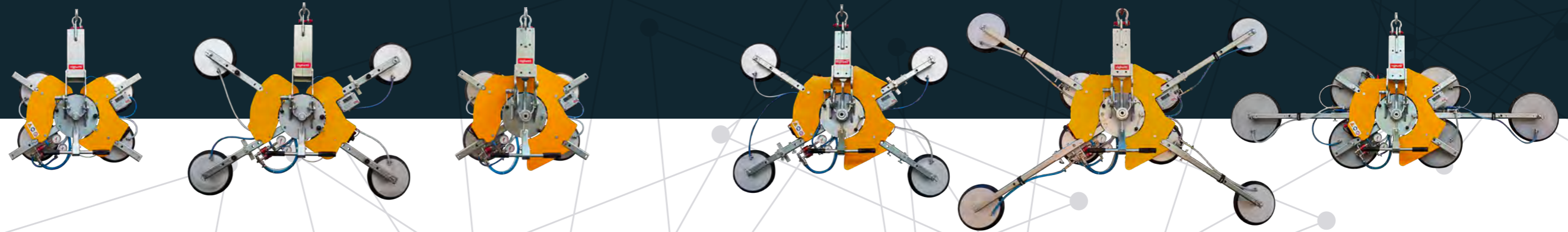

	VBT4	VBT4 PRO	VB4		VB4 PRO		VB4+4		VB4+4 X/XL		
Lifting capacity	kg 400	kg 400	kg 400	kg 600	kg 400	kg 600	kg 800	kg 1200	kg 800	kg 1200	Lifting capacity
Operating system	battery	battery	battery		battery		battery		battery		Operating system
No. of suction pads	4	4	4		4		4+4		4+4		No. of suction pads
Diameter of pad	310 mm	310 mm	kg 310	kg 390	310 mm	390 mm	310 mm	390 mm	310 mm	390 mm	Diameter of pad
Rotation 360° (manual)	✓	✓	✓		✓		✓		✓		Rotation 360° (manual)
Tilt 0-90° (manual)	✓	✓	✓		✓		✓		✓		Tilt 0-90° (manual)
Dual vacuum circuit	✓	✓	✓		✓		✓		✓		Dual vacuum circuit
Repositionable pads	✓	✓	✓		✓		✓		✓		Repositionable pads
Pad spread (mm)	863 x 666 1166 x 861	863 x 666 1166 x 861 1535 x 1100 1770 x 310	863 x 666 1166 x 861	1019 x 795 1246 x 941	863 x 666 1166 x 861 1535 x 1100 1770 x 310	1019 x 795 1246 x 941 1630 x 1190 1870 x 390	863 x 666 1700 x 1210 2145 x 1488	1019 x 795 1780 x 1290 2248 x 1596	863 x 666 1700 x 1210 2145 x 1488 2430 x 715 2530 x 310 970 x 310	1019 x 795 1780 x 1290 2248 x 1596 2510 x 800 2610 x 390 1150 x 390	Pad spread (mm)
Extension arms	✗	✓	✗		✓		✓		✓		Extension arms
Lowered hook connection	■ Available on VBT4-CT	■ Available on VBT4-CT PRO	✓		✓		✓		✓		Lowered hook connection
Possibility to install the controlled inclination system	■ Available on VBT4-CT	■ Available on VBT4-CT PRO	✓		✓		✓		✓		Possibility to install the controlled inclination system
Radio remote control	✗	✗	■		■		■		■		Radio remote control

✓ included

✗ not available

■ optional

VB2

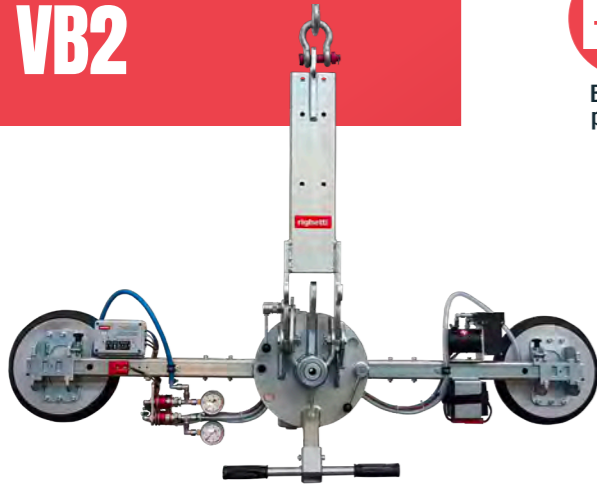

Batteries powered



Manual tilt 0-90°



Manual rotation 360°



2 suction pads



Dual vacuum circuit

The VB2 model is a vacuum glass lifter with two adjustable suction pads, perfect for lifting and handling small or narrow glass panels. VB2 is powered by a rechargeable battery that, if necessary, can be easily removed and quickly replaced. The vacuum glass lifter VB2 RCMBM has 0-90° tilt (horizontal/vertical), with possibility of automatic locking in upright and flat position and continuous 360° rotation, with possibility of automatic locking at each 90°.

Suction pads		Capacity	Product code	Suction pads spread
No.	Ø mm	Kg		mm
2	310	200	VB2 RCMBM	810 x 310
				1660 x 310
2	390	300	VB2 RCMBM d4	890 x 390
				1740 x 390

VB4L



Batteries powered



Manual tilt 0-90°



Manual rotation 360°



4 suction pads



Dual vacuum circuit

The VB4L is a below-the-hook vacuum glass lifter suitable for lifting and handling of long and narrow glass panes. Its four-in-line configuration permits to lift glass whose width goes from 32 cm. Vacuum glass lifter VB4L RCMBM is powered by rechargeable batteries that, if necessary, can be easily removed and quickly replaced.



Wireless radio remote control as optional

Suction pads		Capacity	Product code	Suction pads spread
No.	Ø mm	Kg		mm
4	310	400	VB4L RCMBM	1660 x 310
				1740 x 310
4	390	600	VB4L RCMBM d4	1740 x 390

VB6

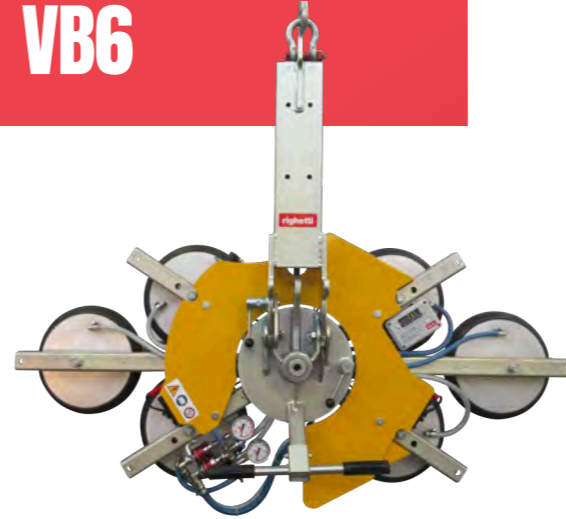

Batteries powered



Manual tilt 0-90°



Manual rotation 360°



6 suction pads



Dual vacuum circuit

The VB6 is 6 pads vacuum lifter with manual 360° continuous rotation and manual tilting system 0-90°. Vacuum glass lifter VB6 RCMBM is powered by rechargeable batteries that, if necessary, can be easily removed and quickly replaced.



Wireless radio remote control as optional

Suction pads		Capacity	Product code	Suction pads spread
No.	Ø mm	Kg		mm
6	310	600	VB6 RCMBM	1420 x 678
				1810 x 678
6	390	900	VB6 RCMBM d4	1810 x 830

VB8

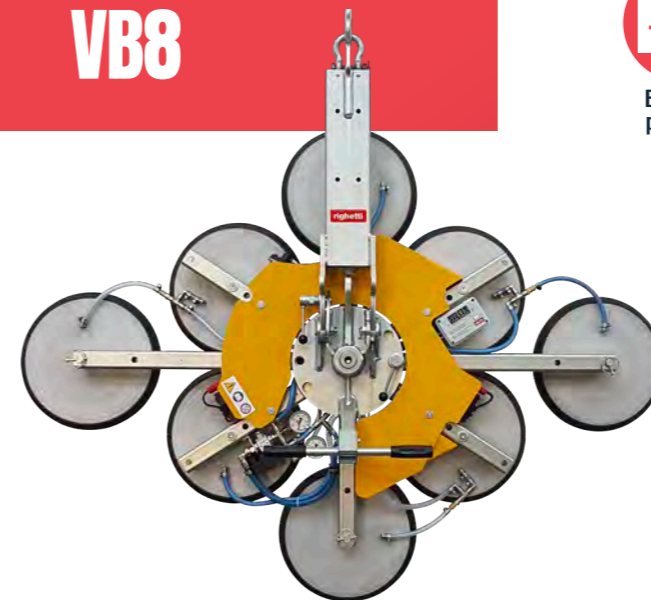

Batteries powered



Manual tilt 0-90°



Manual rotation 360°



8 suction pads



Dual vacuum circuit

The VB8 is a below-the-hook vacuum glass lifter suitable for lifting and handling glass units weighting up to 1200 kg. Vacuum glass lifter VB8 RCMBM is powered by rechargeable and removable batteries. The VB8 RCMBM vacuum lifter features manual tilt and manual 360 degree rotation with possibility of automatic stop or continuous rotation.



Wireless radio remote control as optional

Suction pads		Capacity	Product code	Suction pads spread
No.	Ø mm	Kg		mm
8	310	800	VB8 RCMBM	1420 x 970
				1810 x 970
8	390	1200	VB8 RCMBM d4	1810 x 1360

VB6+4



Batteries powered



Manual tilt 0-90°



Manual rotation 360°



10 suction pads



Dual vacuum circuit



Wireless radio remote control as optional

The VB6+4 is a modular vacuum glass lifter with a maximum lifting capacity of 1000kg. This model is equipped with 6 fixed suction pads, plus 4 external suction pads placed on removable extension arms. By adding or removing the external pads, you can increase or decrease the lifting capacity and pad spread of the vacuum lifter.

Suction pads		Capacity Kg	Product code	Configurations		Suction pads spread mm
No.	Ø mm			Pads in use	Conf. capacity	
10	310	1000	VB6+4 RCMBM	6	600	1420 x 678
				6+4	1000	2145 x 1488

VB8+4



Batteries powered



Manual tilt 0-90°



Manual rotation 360°



12 suction pads



Dual vacuum circuit

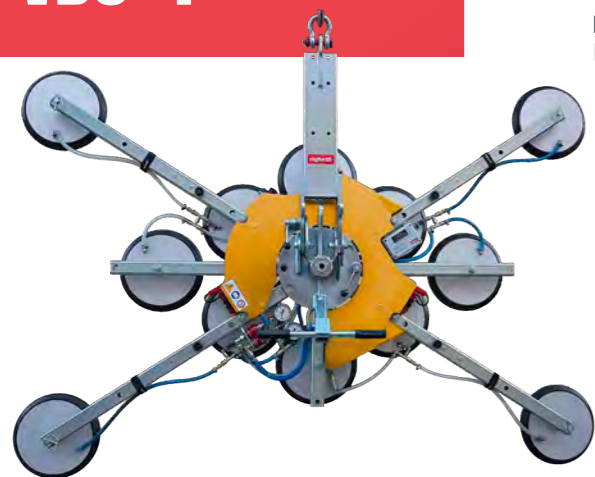

Wireless radio remote control as optional

The VB8+4 is a modular vacuum glass lifter equipped with 12 suction pads. This model is particularly helpful in handling medium to large glass panes. On VB8+4 model, the four external suction pads are on removable extension arms that can increase the lifting capacity and the pad spread.

Suction pads		Capacity Kg	Product code	Configurations		Suction pads spread mm
No.	Ø mm			Pads in use	Conf. capacity	
12	310	1200	VB8+4 RCMBM	8	800	1420 x 970
				8+4	1200	2145 x 1488

GLAXTER



Batteries powered



Manual tilt 0-90°



Manual rotation 360°



6/10 suction pads



Dual vacuum circuit

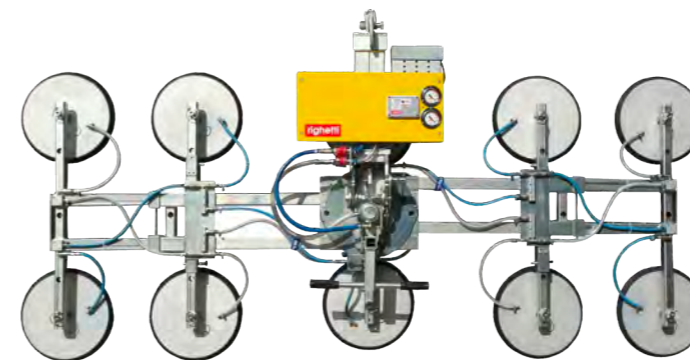

Wireless radio remote control as optional

Glaxter is a modular glass vacuum lifter that adapts to different sizes and shapes of glass. Starting from 2 suction pads and a lifting capacity of 240kg, the ultra-compact Glaxter lifter can quickly and easily morph into a large size lifter, equipped with 6 or 10 pads.

GLAXTER 1200 kg

Kg max 1200

Suction pads		Capacity Kg	Product code	Configurations			Suction pads spread mm
No.	Ø mm			Pads in use	Conf. capacity	Dimensions	
6	390	720	GL-6	2	240	X1 * Y1	390 x 916
				4	480	X2 * Y1	1040 x 916
				6	720	X3 * Y1	1238 x 916
				6	720	X4 * Y1	2026 x 916
10		1200	GL-10	10	1200	X5 * Y1	2268 x 916
				10	1200	X6 * Y1	3056 x 916

Technical drawings

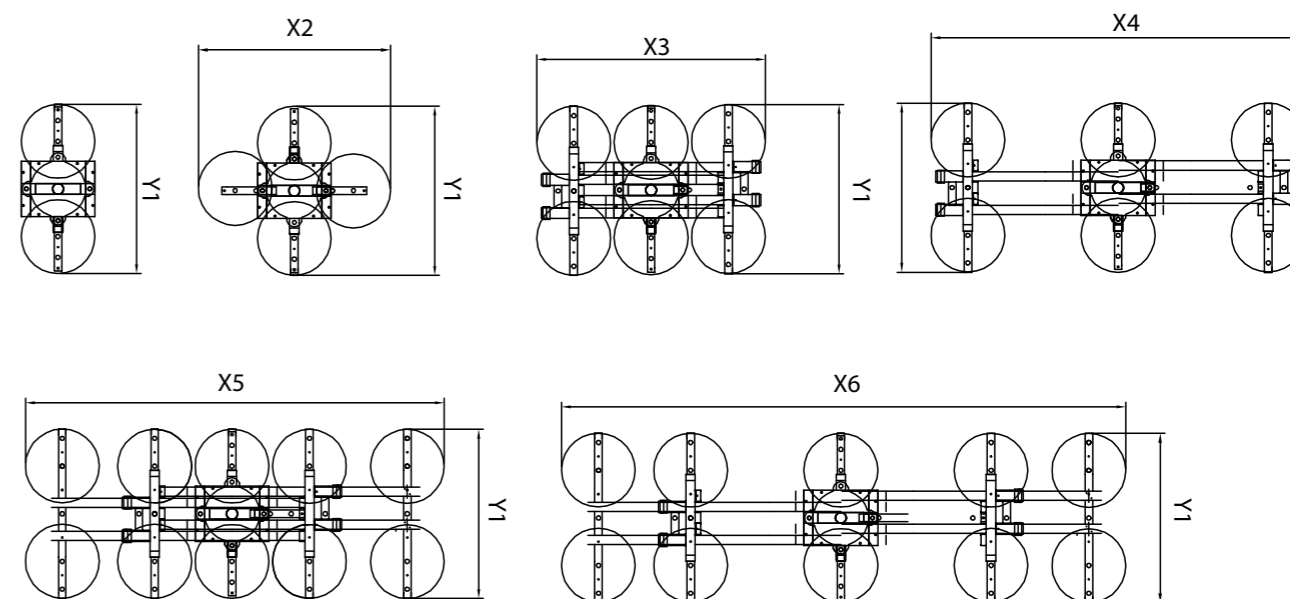

GL-VB2



Batteries powered



Manual tilt 0-90°



Manual rotation 360°



2 suction pads



Dual vacuum circuit

The GL-VB2 model is a vacuum lifter with 2 suction pads whose lifting capacity is 200kg or 300kg. This vacuum lifter is ideal for handling small glass panes. You can choose between two beam lengths: short beam (900mm) or standard beam (1500mm).

Suction pads		Capacity	Product code
No.	Ø mm	Kg	
2	310	200	GL-VB2
2	390	300	GL-VB2 d4

GL-VB4L



Batteries powered



Manual tilt 0-90°



Manual rotation 360°



4 suction pads



Dual vacuum circuit

The GL-VB4L model is a vacuum lifter with 4 in-line suction pads and 400 kg or 600 kg lifting capacity. This model is great for lifting long and narrow glass panes. This lifter features a manual 0-90° tilt system and manual 360° continuous rotation.

Suction pads		Capacity	Product code
No.	Ø mm	Kg	
4	310	400	GL-VB4L
4	390	600	GL-VB4L d4

GL-VB4TR



Batteries powered



Manual tilt 0-90°



Manual rotation 360°



4 suction pads



Dual vacuum circuit

The GL-VB4TR model is a vacuum lifter with 4 repositionable suction pads. GL-VB4TR is a modular vacuum lifter: the suction pads can be positioned on cross arms or in a row on the main beam. Moreover, two pads can be removed for creating a two-in-line configuration.

Suction pads		Capacity	Product code
No.	Ø mm	Kg	
4	310	400	GL-VB4TR
4	390	600	GL-VB4TR d4

VB-SP2



Batteries powered



4 suction pads



Dual vacuum circuit

Vacuum lifter VB-SP2 is a battery powered model ideal for construction site use, since it is equipped with a dual vacuum circuit (in accordance to EN13155). Its lifting capacity is up to 400kg. VB-SP2 is really useful on construction site thanks to its vertically fixed frame, which makes it easy to move glass panes placed in a vertical position.

Suction pads		Capacity	Product code
No.	Ø mm	Kg	
4	310	400	VB-SP2



Wireless radio remote control as default

VB-SP3



Batteries powered



4 suction pads



Dual vacuum circuit

VB-SP3 is the transformable version of VB-SP2. Starting from basic configuration as VB-SP2, the suction pads arms can be removed and attached in a lower position by using lifting sling straps. This configuration is ideal for handling window frames. VB-SP3 can be used on construction site as it is powered by batteries and it features a dual vacuum circuit, in compliance with EN13155 standard.

Suction pads		Capacity	Product code
No.	Ø mm	Kg	
4	310	400	VB-SP3



Wireless radio remote control as default

SLIM



Batteries powered



Manual tilt 0-90°



Manual rotation 360°



4/6 suction pads



Dual vacuum circuit



Wireless radio remote control as optional

The SLIM model is a vacuum lifter with 4-in-line suction pads. Its flat and compact design allows SLIM to work behind scaffoldings. Its removable lifting arm lets you reduce the depth of the lifter to just 143mm. SLIM is available also with two extension arms to further extend its length. The manual 0 – 90° tilting system allows the movement of the glass from vertical to horizontal and vice versa.

SLIM4

Kg max 500

Suction pads		Capacity Kg	Product code	Configurations	Suction pads spread
No.	Ø mm				mm
4	310	400	SLIM4	X1*Y1	1540 x 310
4	390	500	SLIM4 d4		1597 x 390

SLIM4+2

Kg max 500

Suction pads		Capacity Kg	Product code	Configurations			Suction pads spread
No.	Ø mm			Pads in use	Conf. capacity	Dimensions	mm
6	310	500	SLIM4+2	4	400	X1*Y1	1540 x 310
				6	500	X2*Y2	2340 x 310
6	390	500	SLIM4+2 d4	4	500	X1*Y1	1597 x 390
				6	500	X2*Y2	2424 x 390

Technical drawings

SLIM

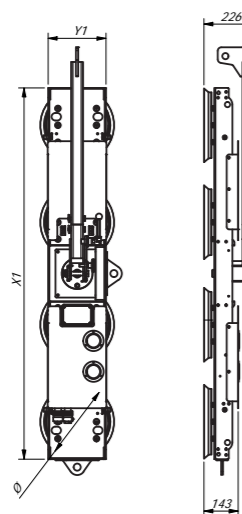

SLIM4+2

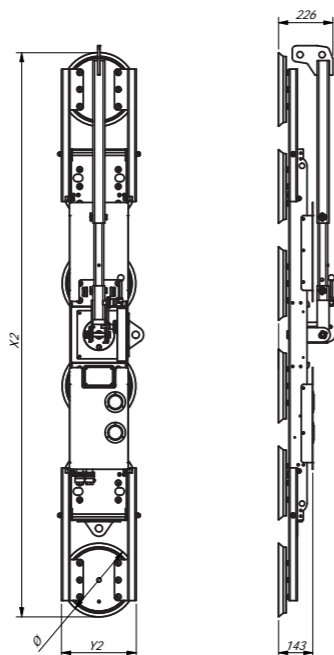

Righetti has a wide range of battery powered vacuum lifters specific for construction site with electric movements.

These vacuum lifters are specifically designed for working outdoors, as they are equipped with a dual vacuum circuit and safety systems to warn you about potential dangers.

Moreover, they are operated by high-capacity batteries, which can be easily removed and recharged.

In the models hereby presented, tilt and rotation are powered and commanded at a distance via a wireless radio remote control.

VACUUM CONTROL UNIT

An on-board computer (PLC) that constantly controls the vacuum lifter and its safety components, besides executing a self-diagnostics to guarantee the well-functioning. It is also equipped with:

- **ACOUSTIC AND VISUAL ALARMS** to warn the worker about possible dangers
- **BATTERIES STATUS INDICATOR** to keep the batteries level under control
- **A BUILT-IN ECONOMIZER** to lengthen batteries life

DUAL VACUOMETER

with a color scale to monitor vacuum level in the circuits

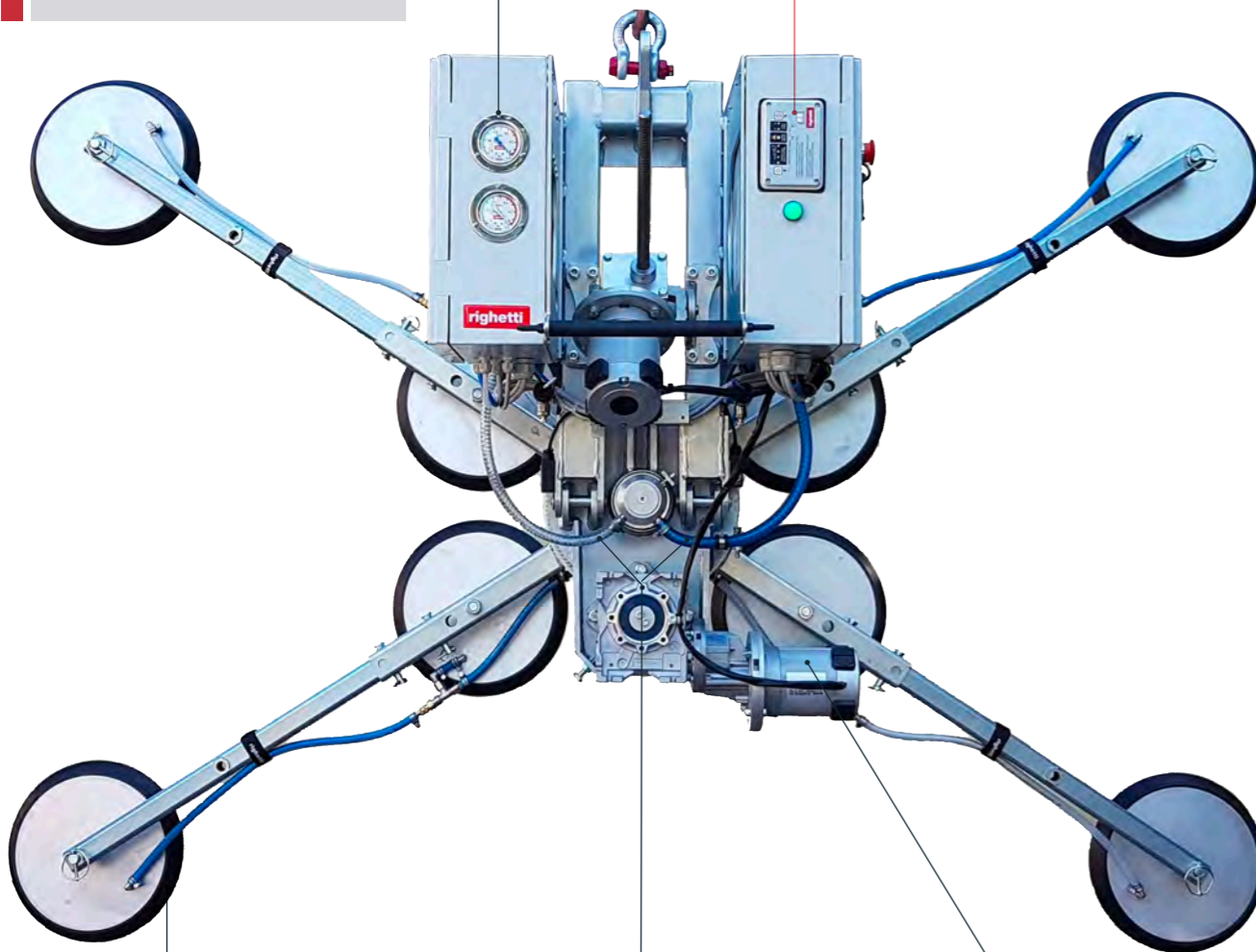

GLASS-SPECIFIC SUCTION PADS

equipped with a safety lip and rings, plus double spring system to compensate the flexion of the load

DUAL VACUUM CIRCUIT

to guarantee safety in compliance with standard EN13155

ELECTRIC MOVEMENTS

to precisely control tilt and rotation

Glass vacuum lifters

battery powered

with electric movements



Batteries operated



Electric Rotation 360°



Electric tilt 0-90°

Righetti
smart vacuum lifters

5 reasons for choosing our models with electric movements

1 Double kit of removable and easily replaceable batteries

Righetti batteries are quick to replace and easy to recharge. Designed for your safety, the charge level will always be indicated by the indicator light. And to never stop your construction site, you can have an extra kit and separate charger included: while you're working, you can always have a pair of batteries charging.

2 Precise movements thanks to electric mechanism

While handling glass panes, precision is the key. Using a Righetti vacuum lifter with powered movements, you can easily manage glass tilt and rotation at a distance with pinpoint accuracy by using the radio remote control.

3 Instant suction for faster work

Vacuum lifters' job is to make your workload easier and faster. Because of this, suction pads are designed and created to perfectly adapt to the surface of the load. At activation of suction, our special vacuum circuit guarantees immediate aspiration of the glass panels. Within few seconds you can safely handle and lift the load.

4 Modular frame

What makes Righetti vacuum lifters truly appealing to workers is their flexibility and modularity. Starting from the basic VB4, equipped with four repositionable suction pads, you can upgrade up to the most modular vacuum lifter VB4+4 XL. Using the latter lifter to handle your glass panes, you can create more than 8 configurations to adjust to all your needs: the size and shape of glass panes won't bother you anymore.

5 Suction pads with low vacuum dispersion

At Righetti, we accurately study every detail of our vacuum lifters: suction pads are one of those aspects on which we concentrated much energy to come up with the perfect solution. Our suction pads gaskets are sealed with safety lip and rings for extra hold. Moreover, suction pads have spring system to best compensate the flexion of glass sheets.

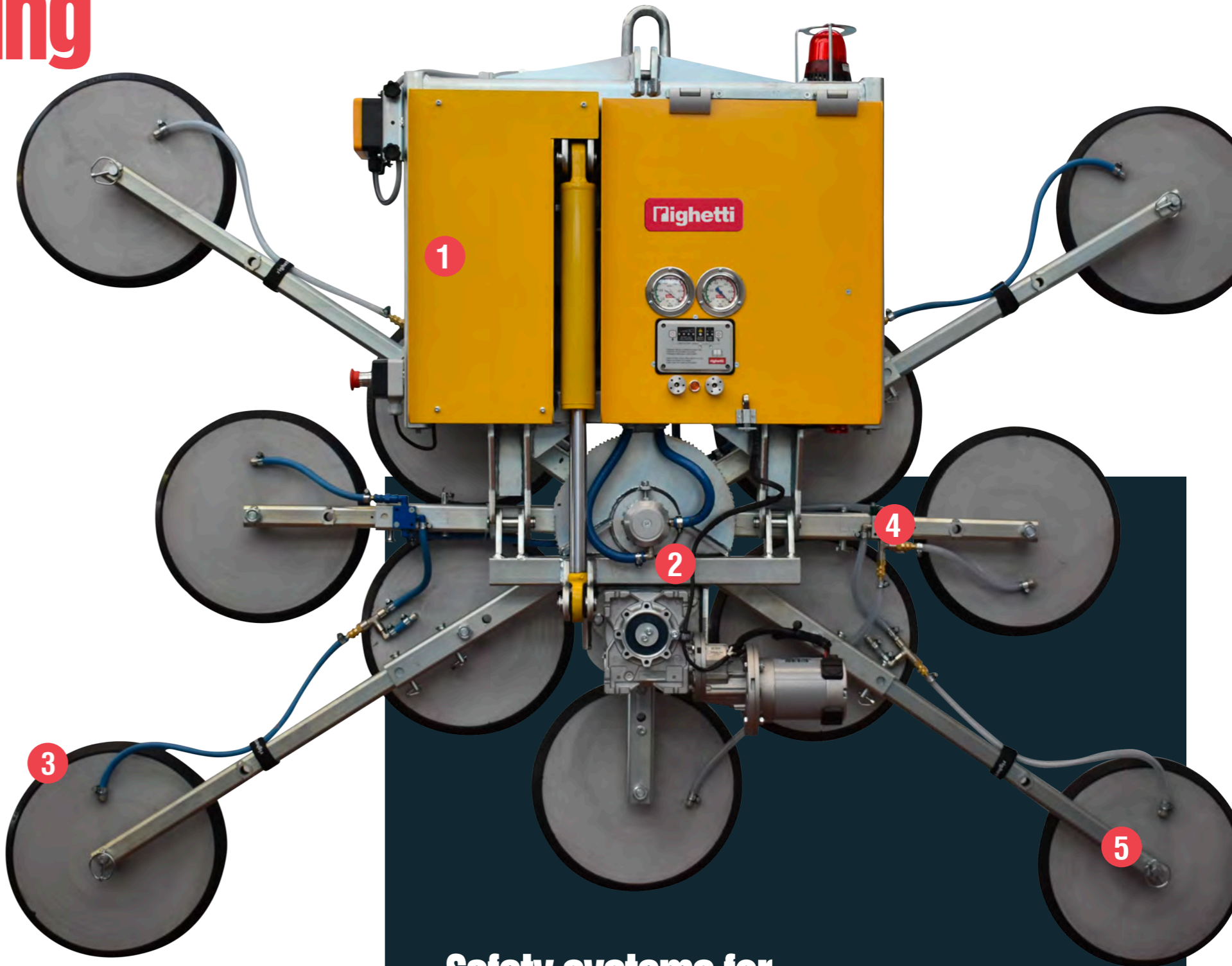
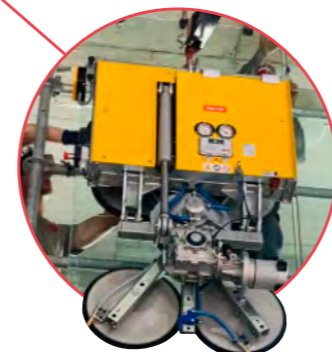

Safety systems for the load and the workers

For safely working on construction sites in compliance with EN13155, our vacuum lifters are equipped with a high-performing control unit that will warn you in case of any dangerous

situations. Moreover, all the models dedicated to construction sites have a dual vacuum circuit and reservoir to guarantee the hold of the load even in case of malfunctions.

VB4 RCEBE



Batteries powered



Electric tilt 0-90°



Electric rotation 360°



4 suction pads



Dual vacuum circuit



Wireless radio remote control as default

The VB4 RCEBE with electric movements is a battery-powered vacuum lifter with continuous 360° electric rotation and powered tilt. The rechargeable batteries can be easily removed and quickly replaced.

Besides having both electric movements, this model is available in other two possible combinations: manual tilt and electric rotation or electric tilt and manual rotation.

Moreover, you can place the suction pads in two different positions for lifting both small and medium glass panes.

VB4 RCEBE 400kg

Kg max 400

Suction pads		Capacity	Model with			Configurations	Suction pads spread
No.	Ø mm	Kg	electric tilt and electric rotation	manual tilt and electric rotation	electric tilt and manual rotation		mm
4	310	400	VB4 RCEBE	VB4 RCEBM	VB4 RCMBE	X1 * Y1	863 x 666
						X2 * Y2	1166 x 861

VB4 RCEBE d4 600kg

Kg max 600

Suction pads		Capacity	Model with			Configurations	Suction pads spread
No.	Ø mm	Kg	electric tilt and electric rotation	manual tilt and electric rotation	electric tilt and manual rotation		mm
4	390	600	VB4 RCEBE d4	VB4 RCEBM d4	VB4 RCMBE d4	X1 * Y1	1019 x 795
						X2 * Y2	1246 x 941

Technical drawings

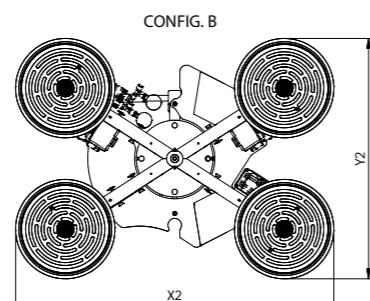
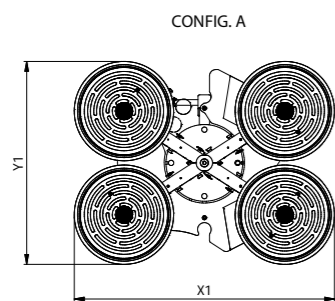

VB4 RCEBE PRO

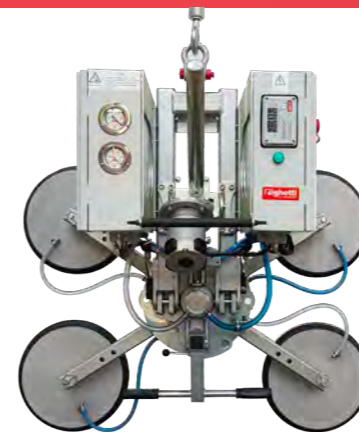

Batteries powered



Electric tilt 0-90°



Electric rotation 360°



4 suction pads



Dual vacuum circuit



Wireless radio remote control as default

VB4 RCEBE PRO is the upgraded glass vacuum lifter of the standard VB4. Its 4 adjustable suction pads allow you to create several configurations for a safe handle of small glass, large panes, and long and narrow sheets. Thanks to its modularity, VB4 PRO gives you huge flexibility for working on construction site. Moreover, it is equipped with rechargeable and removable batteries, manual or electric tilt, manual or powered continuous rotation, safety devices and a dual vacuum circuit.

VB4 RCEBE PRO 400KG

Kg max 400

Suction pads		Capacity	Model with			Configurations	Suction pads spread
No.	Ø mm	Kg	electric tilt and electric rotation	manual tilt and electric rotation	electric tilt and manual rotation		mm
4	310	400	VB4 RCEBE PRO	VB4 RCEBM PRO	VB4 RCMBE PRO	X1 * Y1	863 x 666
						X2 * Y2	1166 x 861
						X3 * Y3	1535 X 1100
						X4 * Y4	1770 X 310

VB4 RCEBE d4 PRO 600kg

Kg max 600

Suction pads		Capacity	Model with			Configurations	Suction pads spread
No.	Ø mm	Kg	electric tilt and electric rotation	manual tilt and electric rotation	electric tilt and manual rotation		mm
4	390	600	VB4 RCEBE d4 PRO	VB4 RCEBM d4 PRO	VB4 RCMBE d4 PRO	X1 * Y1	1019 x 795
						X2 * Y2	1246 x 941
						X3 * Y3	1630 x 1190
						X4 * Y4	1870 x 390

Technical drawings

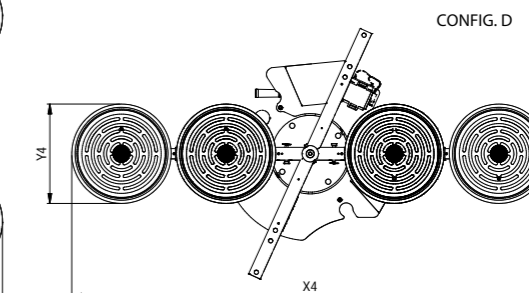
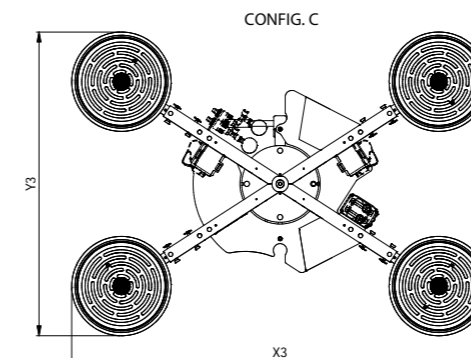
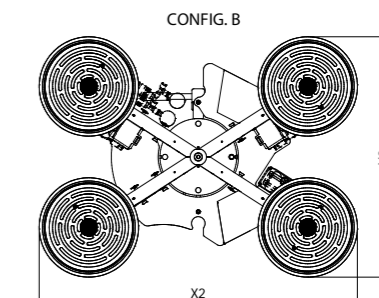
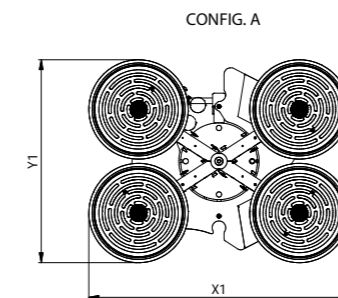

VB4+4 RCEBE

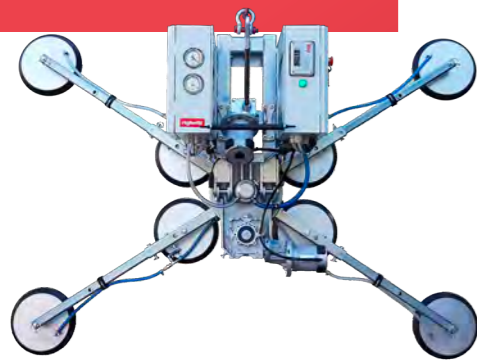

Batteries powered



Electric tilt 0-90°



Electric rotation 360°



8 suction pads



Dual vacuum circuit



Wireless radio remote control as default

VB 4+4 RCEBE is a glass vacuum lifter that offers you wide flexibility. This model is equipped with 4 fixed suction pads, plus 4 external suction pads placed on removable extension arms. By adding or removing the external pads, you can increase or decrease the lifting capacity and pad spread of the vacuum lifter. It can be built with manual tilt and electric rotation, electric tilt and manual rotation, or both electric movements.

VB4+4 RCEBE 800kg

Kg max 800

Suction pads		Capacity	Model with			Configurations			Suction pads spread
No.	Ø mm	Kg	electric tilt and electric rotation	manual tilt and electric rotation	electric tilt and manual rotation	Pads in use	Conf. capacity	Dimensions	mm
8	310	800	VB4+4 RCEBE	VB4+4 RCEBM	VB4+4 RCMBE	4	400	X1 * Y1	863 x 666
						4+4	800	X2 * Y2	1700 x 1210
						4+4	800	X3 * Y3	2145 x 1488

VB4+4 RCEBE d4 1200kg

Kg max 1200

Suction pads		Capacity	Model with			Configurations			Suction pads spread
No.	Ø mm	Kg	electric tilt and electric rotation	manual tilt and electric rotation	electric tilt and manual rotation	Pads in use	Conf. capacity	Dimensions	mm
8	390	1200	VB4+4 RCEBE d4	VB4+4 RCEBM d4	VB4+4 RCMBE d4	4	600	X1 * Y1	1019 x 795
						4+4	1200	X2 * Y2	1780 x 1290
						4+4	1200	X3 * Y3	2248 x 1596

Technical drawings

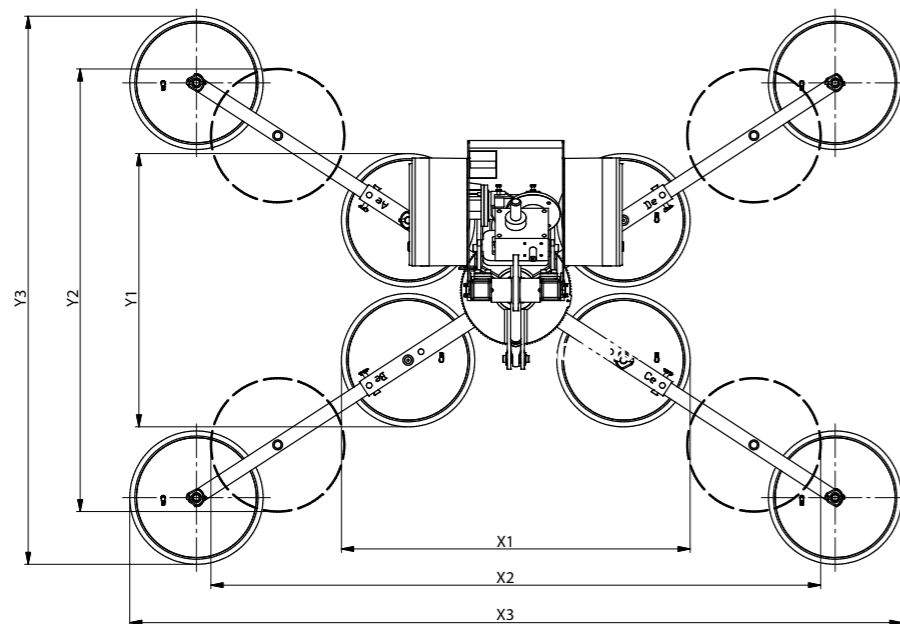

VB4+4 RCEBE X/XL

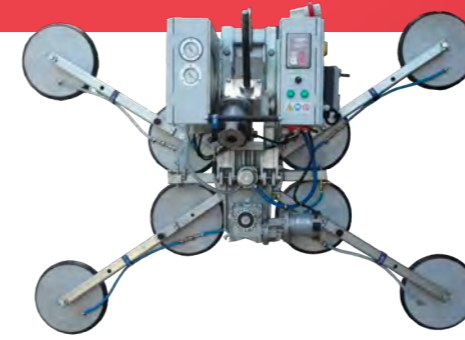

Batteries powered



Electric tilt 0-90°



Electric rotation 360°



8 suction pads



Dual vacuum circuit



Wireless radio remote control as default

VB4+4 RCEBE X/XL is the upgraded version of VB4+4. What makes this model extremely interesting is the wide range of configurations and alignments that can be created. This model is equipped with 8 suction pads and 4 extension arms, thus giving the operator the power to easily change configurations. By adding or removing the suction pads, you can increase or decrease the lifting capacity and pad spread of the vacuum lifter.

VB4+4 RCEBE X / XL 800kg

Kg max 800

Suction pads		Capacity	Model with			Configurations			Suction pads spread
No.	Ø mm	Kg	electric tilt and electric rotation	manual tilt and electric rotation	electric tilt and manual rotation	Pads in use	Conf. capacity	Dimensions	mm
8	310	800	VB4+4 RCEBE X	VB4+4 RCEBM X	VB4+4 RCMBE X	4	400	X1 * Y1	863 x 666
						4+4	800	X2 * Y2	1700 x 1210
						4+4	800	X3 * Y3	2145 x 1488
			4+2	600	X4 * Y4	2430 x 715			
			4 (line)	400	X5 * Y5	2530 x 310			
			2	200	X6 * Y5	970 x 310			

VB4+4 RCEBE d4 X / XL 1200kg

Kg max 1200

Suction pads		Capacity	Model with			Configurations			Suction pads spread
No.	Ø mm	Kg	electric tilt and electric rotation	manual tilt and electric rotation	electric tilt and manual rotation	Pads in use	Conf. capacity	Dimensions	mm
8	390	1200	VB4+4 RCEBE d4 X	VB4+4 RCEBM d4 X	VB4+4 RCMBE d4 X	4	600	X1 * Y1	1019 x 795
						4+4	1200	X2 * Y2	1780 x 1290
						4+4	1200	X3 * Y3	2248 x 1596
			4+2	900	X4 * Y4	2510 x 800			
			4 (line)	600	X5 * Y5	2610 x 390			
			2	300	X6 * Y5	1150 x 390			

Technical drawings

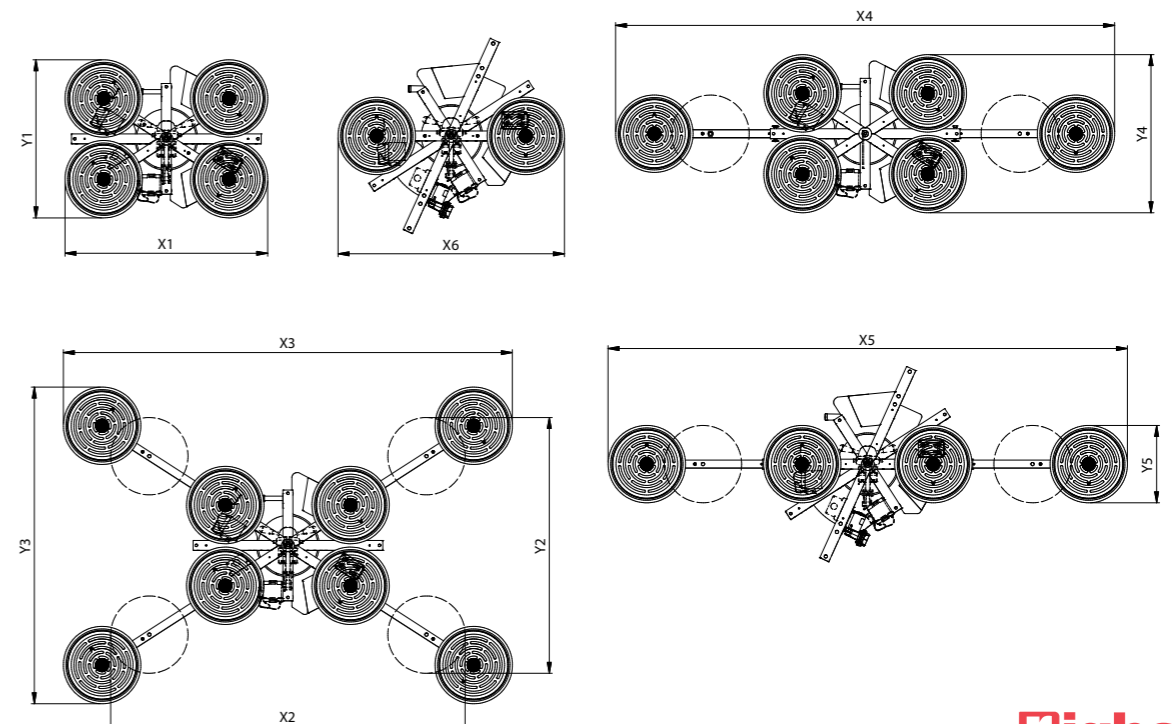

VB4L RCEBE



Batteries powered



Electric tilt 0-90°



Electric rotation 360°



4 suction pads



Dual vacuum circuit

The VB4L RCEBE is a battery-powered vacuum lifter with 4 suction pads in a row. It can lift up to 400 kg or 600 kg. It can be equipped with manual tilt and electric rotation, electric tilt and manual rotation, or both electric movements. The aspiration, release and tilting commands are controlled by wireless radio remote control.



Wireless radio remote control as default

Suction pads		Capacity	Model with			Suction pads spread
No.	Ø mm	Kg	electric tilt and electric rotation	manual tilt and electric rotation	electric tilt and manual rotation	mm
4	310	400	VB4L RCEBE	VB4L RCEBM	VB4L RCMBE	1660 x 310
4	390	600	VB4L RCEBE d4	VB4L RCEBM d4	VB4L RCMBE d4	1740 x 390

VB8 RCEBE



Batteries powered



Electric tilt 0-90°



Electric rotation 360°



8 suction pads



Dual vacuum circuit



Wireless radio remote control as default

The VB8 RCEBE model is a battery-powered vacuum lifter with 8 suction pads. Its lifting capacity can go up to 800 kg or 1200 kg. Its continuous rotation and tilting system could either be manual or electric. This model is powered by removable and rechargeable batteries.

Suction pads		Capacity	Model with			Suction pads spread
No.	Ø mm	Kg	electric tilt and electric rotation	manual tilt and electric rotation	electric tilt and manual rotation	mm
8	310	800	VB8 RCEBE	VB8 RCEBM	VB8 RCMBE	1420 x 970
8	390	1200	VB8 RCEBE d4	VB8 RCEBM d4	VB8 RCMBE d4	1810 x 830

VB6 RCEBE



Batteries powered



Electric tilt 0-90°



Electric rotation 360°



6 suction pads



Dual vacuum circuit

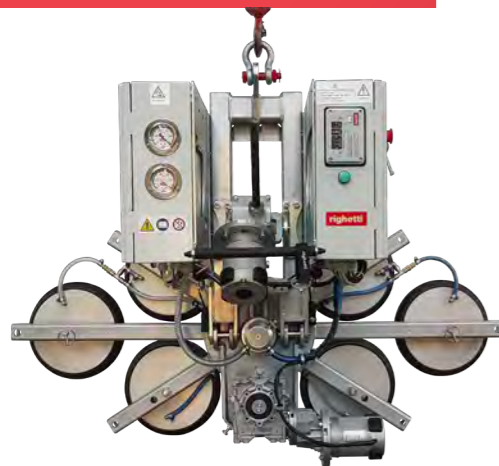

Wireless radio remote control as default

The VB6 RCEBE is a battery-powered vacuum lifter with lifting capacity up to 600 or 900 kg. Its tilting system and rotation can be either electric or manual. The operating system is powered by rechargeable and removable batteries. The aspiration, release and tilting and rotating commands are controlled by wireless radio remote control.

Suction pads		Capacity	Model with			Suction pads spread
No.	Ø mm	Kg	electric tilt and electric rotation	manual tilt and electric rotation	electric tilt and manual rotation	mm
6	310	600	VB6 RCEBE	VB6 RCEBM	VB6 RCMBE	1420 x 678
6	390	900	VB6 RCEBE d4	VB6 RCEBM d4	VB6 RCMBE d4	1810 x 830

VB6+4 RCEBE



Batteries powered



Electric tilt 0-90°



Electric rotation 360°



10 suction pads



Dual vacuum circuit

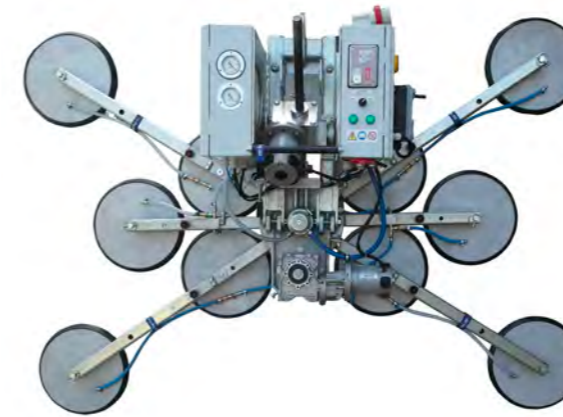

Wireless radio remote control as default

VB6+4 RCEBE is a modular glass vacuum lifter. This model has 6 fixed suction pads plus 4 external pads placed on removable extension arms. Adding the 4 external arms lets you increase the lifting capacity from 600kg to 1000kg. This model is powered by easily removable and rechargeable batteries.

Suction pads		Capacity	Model with			Configurations		Suction pads spread
No.	Ø mm	Kg	electric tilt and electric rotation	manual tilt and electric rotation	electric tilt and manual rotation	Pads in use	Conf. capacity	mm
10	310	1000	VB6+4 RCEBE	VB6+4 RCEBM	VB6+4 RCMBE	6	600	1420 x 678
						6+4	1000	2145 x 1488

GLE 4+8



Batteries powered



Electric tilt 0-90°



Electric rotation 360°



12 suction pads



Dual vacuum circuit

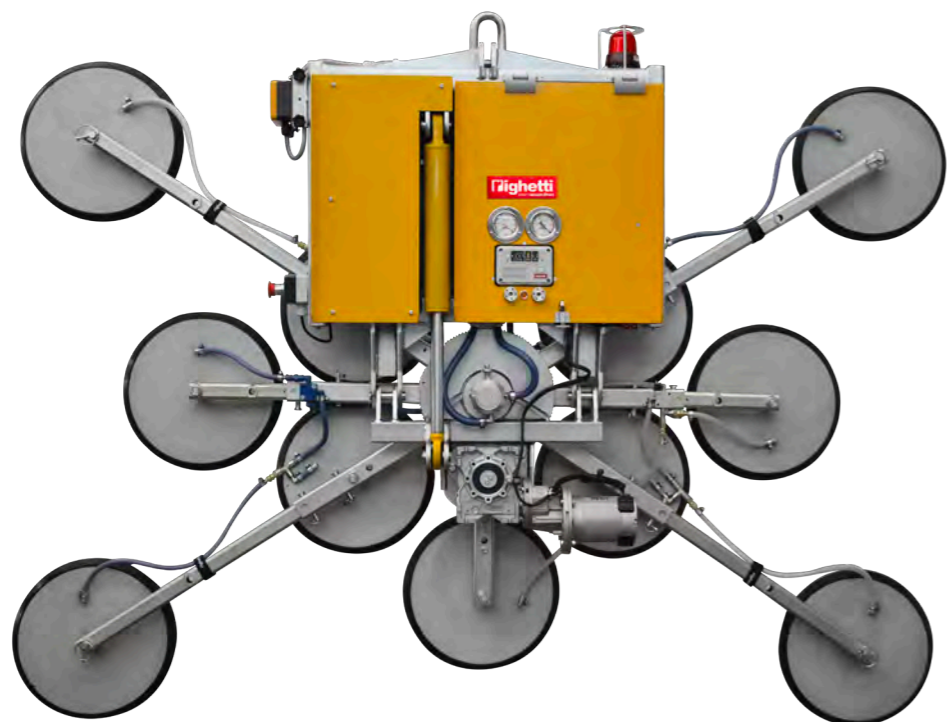

GLE4+8 is a modular vacuum lifter with up to 1500 kg lifting capacity. GLE4+8's modularity allows you to handle small, medium and large glass panes. This model has continuous 360° electric rotation and 0-90° electric tilt and it is powered by rechargeable and easily removable batteries. The compact size of the control unit box gives the lifter an outstanding width of only 318mm, making it possible to reach even the toughest spots.

GLE 4+8 d3 1200kg

Kg max 1200

Suction pads		Capacity	Product code	Configurations			Suction pads spread
No.	Ø mm	Kg		Pads in use	Conf. capacity	Dimensions	mm
12	310	1200	GLE 4+8 d3	4	400	X1 * Y1	945 x 725
				6	600	X2 * Y1	1690 x 725
				8	800	X2 * Y2	1690 x 1295
				8	800	X3 * Y3	2175 x 1525
				10	1000	X3 * Y3	2175 x 1525
				12	1200	X3 * Y3	2175 x 1525

GLE 4+8 d4 1500kg

Kg max 1500

Suction pads		Capacity	Product code	Configurations			Suction pads spread
No.	Ø mm	Kg		Pads in use	Conf. capacity	Dimensions	mm
12	390	1500	GLE 4+8 d4	4	500	X1 * Y1	1020 X 800
				6	750	X2 * Y1	1765 x 800
				8	1000	X2 * Y2	1765 x 1370
				8	1000	X3 * Y3	2250 x 1600
				10	1250	X3 * Y3	2250 x 1600
				12	1500	X3 * Y3	2250 x 1600

Technical drawings

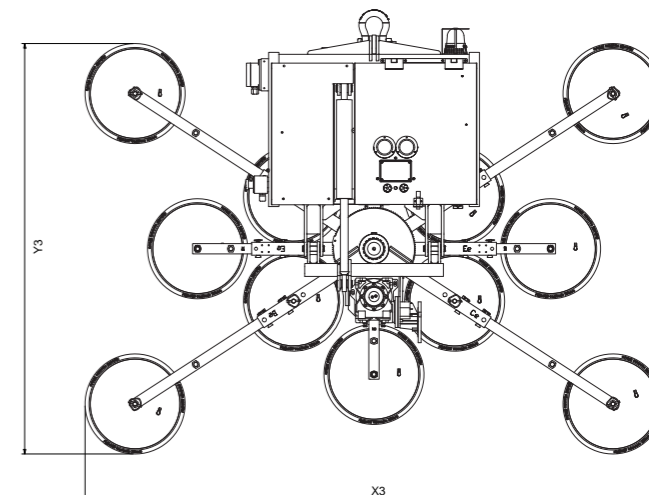
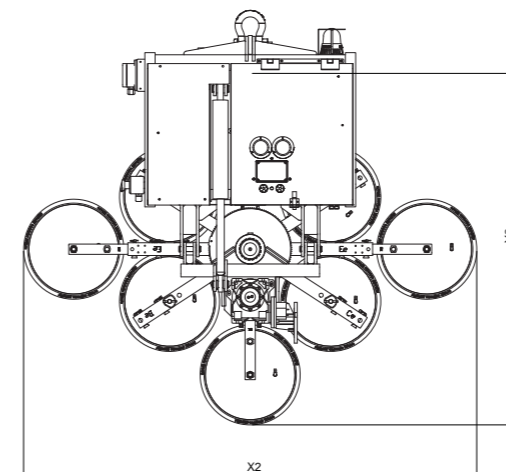
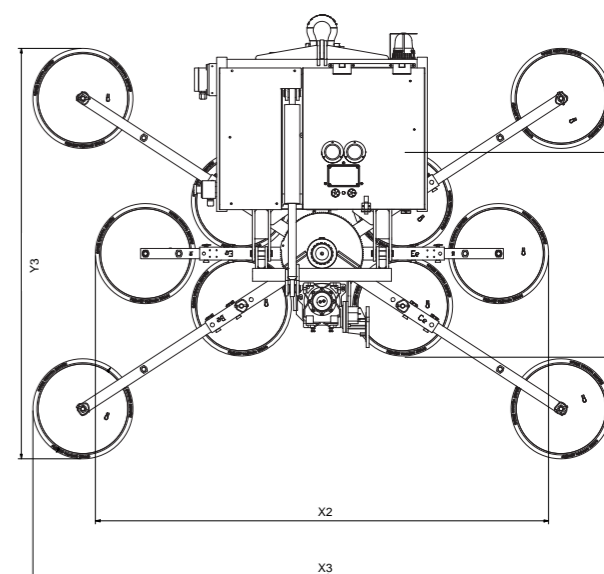
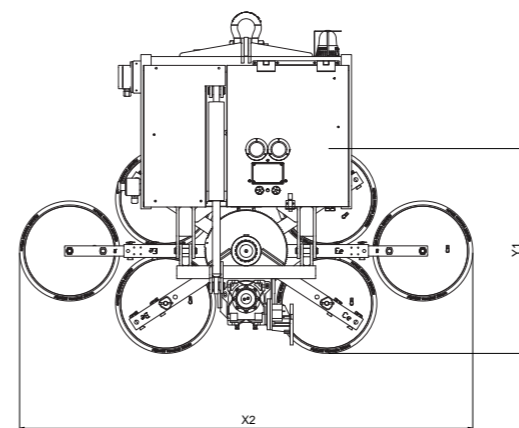
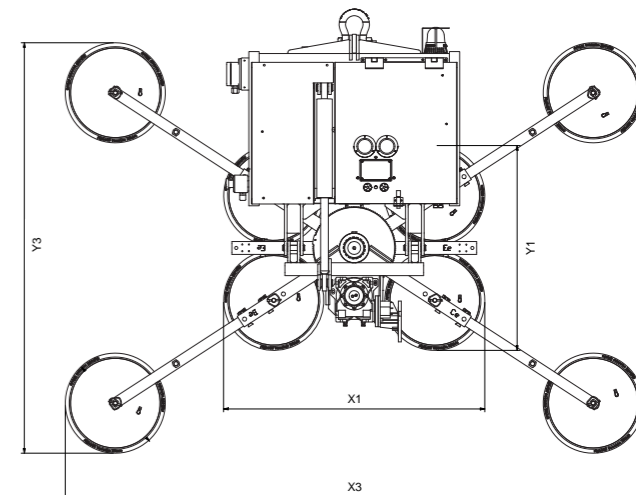
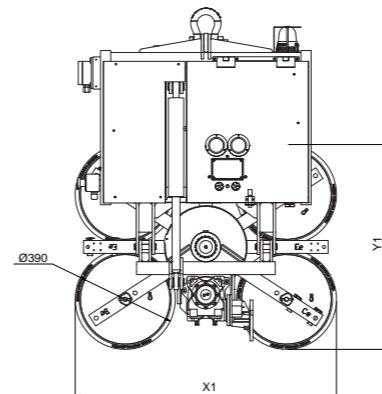

GLE2200



Batteries powered



Electric tilt 0-90°



Electric rotation 360°



16 suction pads



Dual vacuum circuit

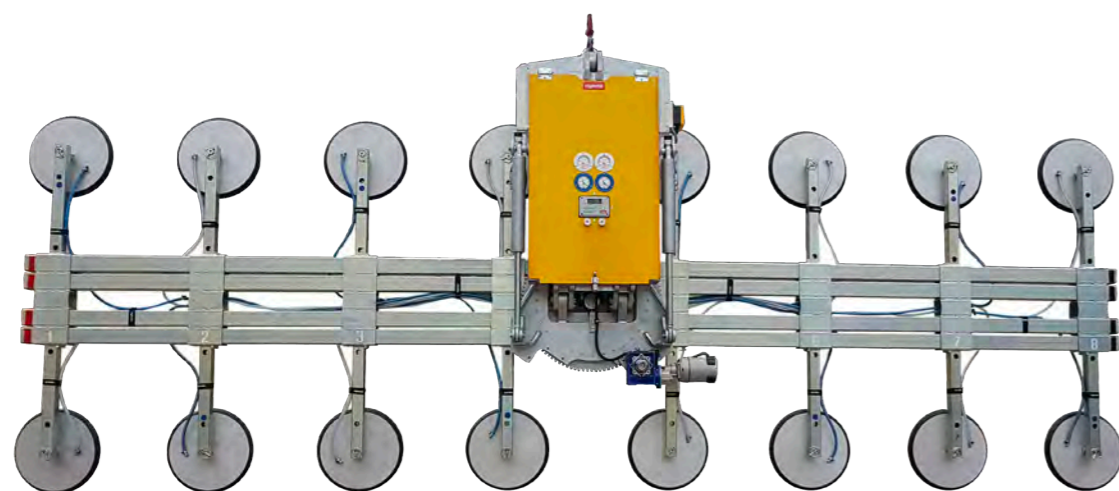

GLE2200 is modular vacuum lifter with up to 2200 kg lifting capacity, which make it perfect for big, heavy glass installations. The GLE2200 has continuous 360° electric rotation and electric 0-90° tilt. It is powered by high-capacity batteries, which can be removed and recharged.

GLE2200

Kg max 2200

Suction pads		Capacity	Product code	Configurations		Suction pads spread
No.	Ø mm	Kg		Pads in use	Conf. capacity	mm
16	390	2200	GLE2200	8	1100	1840 x 1000
						1840 x 1400
						1840 x 1830
				16	2200	4440 x 1000
						4440 x 1830

GLE3000



Batteries powered



Electric tilt 0-90°



Electric rotation 360°



28 suction pads



Four vacuum circuits

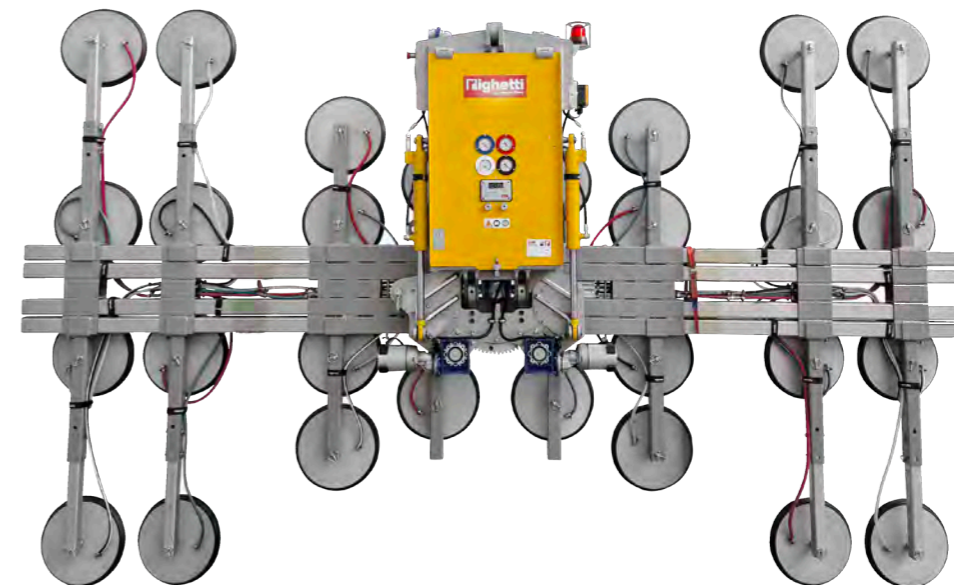

GLE3000 is a modular vacuum lifter with up to 3000 kg lifting capacity, perfect for big and heavy glass installations. It can be used with either 12 or 28 suction pads. The GLE3000 has continuous 360° electric rotation and 0-90° electric tilt, that can be controlled using the wireless remote control. It is powered by high-capacity batteries, which can be removed and recharged.

GLE3000

Kg max 3000

Suction pads		Capacity	Product code	Configurations			Suction pads spread
No.	Ø mm	Kg		Pads in use	Conf. capacity	Dimensions	mm
28	390	3000	GLE3000	12	1500	X1 * Y1	1840 x 1830
				28	3000	X2 * Y1	4440 x 1830
						X2 * Y2	4440 x 2670

Technical drawings

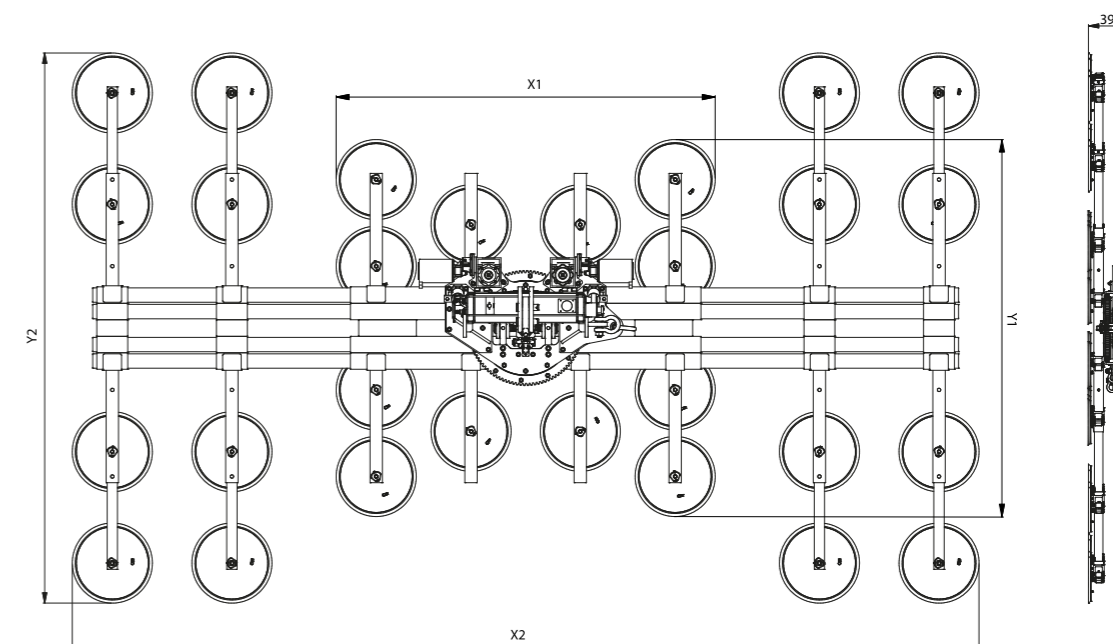

Accessories and optional for VB4 series

Radio remote control

Radio remote control is available on most of the VB series lifters (except for the VB2 RCMBM and VBT4). Please indicate this optional when ordering the vacuum lifter, as it is not available for purchase separately.



Controlled inclination device

Manually controlled inclination mechanism lets you precisely adjust the degree of inclination in both directions (down / up). Controlled inclination system is very useful during the installation of glass or shop windows. This optional can be added to all our VB glass lifter series even in a second moment (for VBT4 choose the version VBT4-CT).



Pads supports for greater distance from the glass

Specific supports to obtain a greater distance between the lifter frame and glass, in cases when you can't use the standard supports with the window frame. This optional has to be authorized by Righetti since it cannot be used on all models.

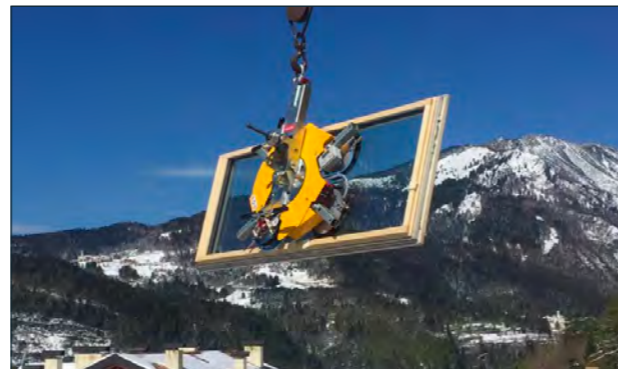

Parking stand

VB series lifters can be equipped with handy parking stands. There are several stands available: standard ones, stand with wheels or forkable stands.

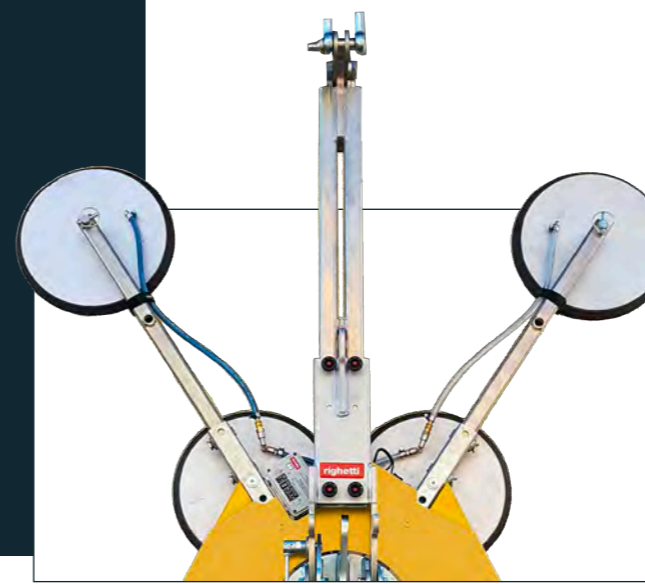
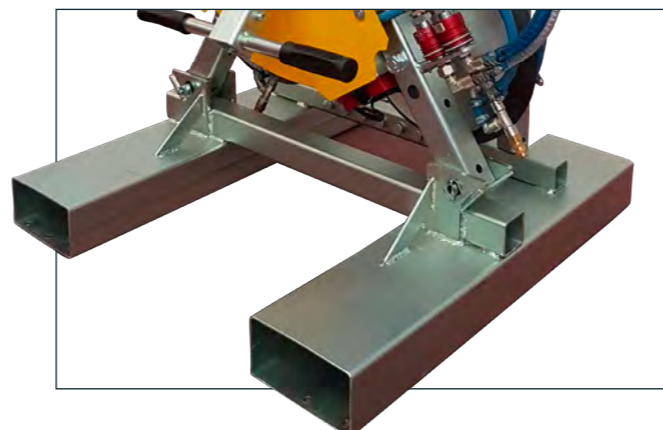

Extension of lifting arm

Removable extension of lifting arm, useful on lifters with removable pad arms. With its higher hook point it lets you keep the glass in a more vertical position.



Pads covers

Protect your pads' gaskets by using specific covers. Covers are built in a special waterproof and resistant material that will keep the pads away from dust, rain and damages.

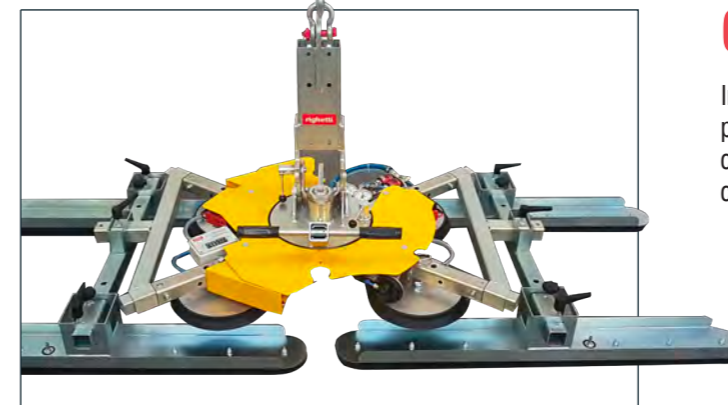

Cladding kit

In certain cases, you might need to install not only glass panes but also sandwich panels. To have your back covered, we offer you a removable kit of pads specific for cladding, in order to install sandwich panels up to 400kg.

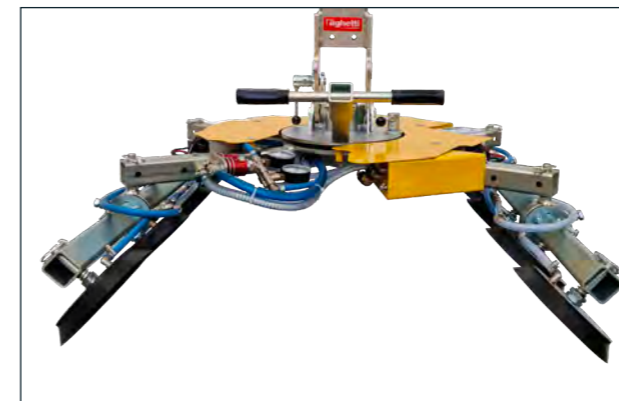

Curved glass kit

VB4 series can now transform into a vacuum lifter for curved glass! Remove all the standard flat pads and change them with specific arms with curved glass pads.

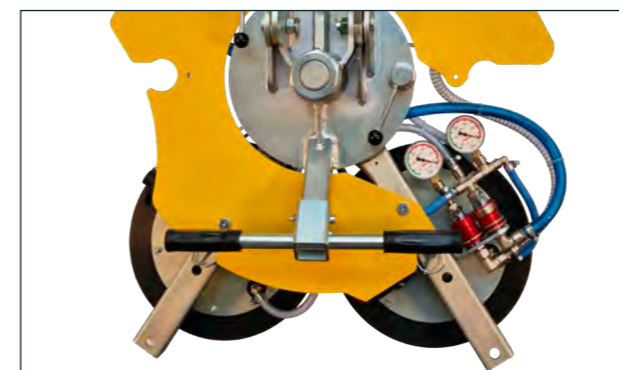

Suction pads for textured glass

To guarantee firm hold on all glass types, even the textured ones, we have designed a special suction pad that will perfectly adjust to the surface.

In its fleet of vacuum lifters, Righetti can count several options for curved glass.

Facing the increasing demands for curved glass in construction environments, Righetti has developed its range of vacuum lifters for satisfying all needs.

Righetti curved glass vacuum lifters are available with different lifting capacity and frames to adapt to all panes. Moreover, they can feature manual or powered movements.

Equipped with high-capacity rechargeable and removable batteries, Righetti vacuum lifters for curved glass are ideal for working on construction sites.

VACUUM CONTROL UNIT

An on-board computer (PLC) that constantly controls the vacuum lifter and its safety components, besides executing a self-diagnostics to guarantee the well-functioning. It is also equipped with:

- **ACOUSTIC AND VISUAL ALARMS** to warn the worker about possible dangers
- **BATTERIES STATUS INDICATOR** to keep the batteries level under control
- **A BUILT-IN ECONOMIZER** to lengthen batteries life

POWERED BY BATTERIES

which are removable and rechargeable

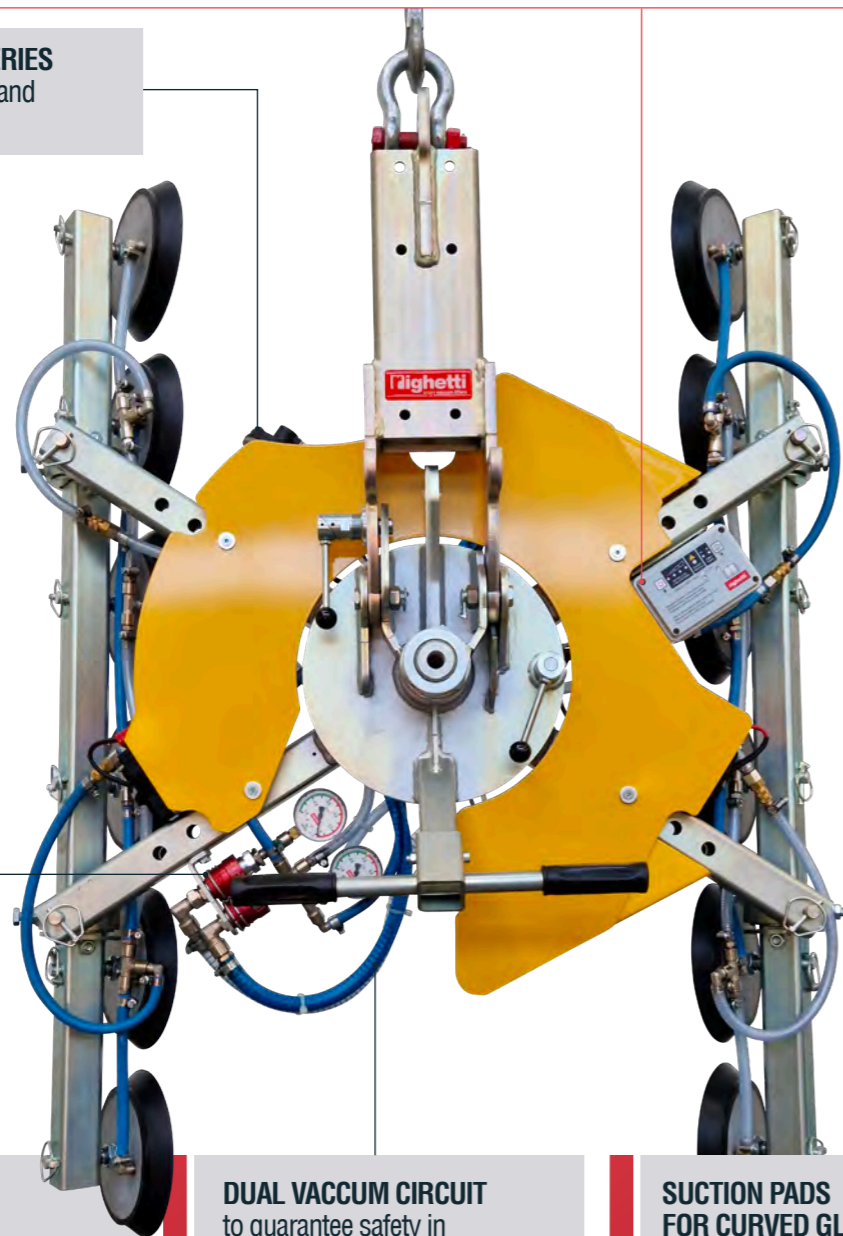

DUAL-ACTION OFF COMMAND

to safely control load suction and release

DUAL VACCUM CIRCUIT

to guarantee safety in compliance with standard EN13155

SUCTION PADS FOR CURVED GLASS

thanks to their gaskets that are specifically designed to adapt to curved surfaces

Glass vacuum lifters

battery powered

for curved glass



Batteries operated



Electric Rotation 360°



Manual Rotation 360°



Electric tilt 0-90°



Manual tilt 0-90°

VB4-C

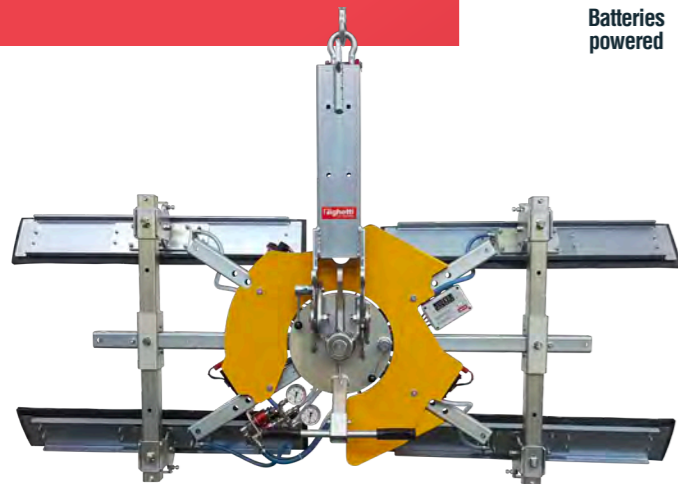

The VB4-C vacuum lifter for curved glass has a max lifting capacity of 400 kg. Its system is operated by removable and rechargeable batteries, which make working on construction site extremely convenient. VB4-C is an easy-to-use vacuum lifter to handle curved glass with compact sizes.

Suction pads		Capacity Kg	Product code	Suction pads spread	
No.	Ø mm			mm	
4	930x170	400	VB4C	2260 x 475	2260 x 750

VB-CG

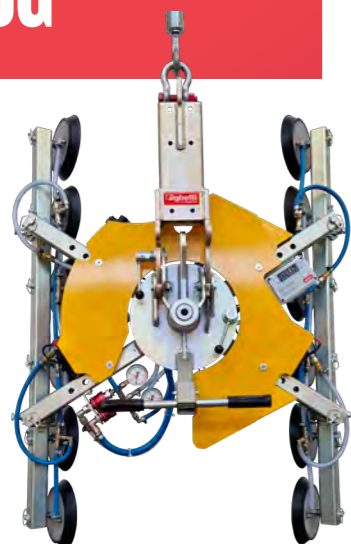

The VB-CG vacuum lifter series is dedicated to lifting curved glass up to 600kg. Thanks to its battery-operated system and its dual vacuum circuit, it is suitable for construction site. It can be equipped with up to 20 suction pads specific for curved glass panes in order to give adequate support to both concave and convex glass.

Suction pads		Capacity Kg	Product code	Suction pads spread	
No.	Ø mm			mm	
12	200	400	VB12CG	507/1006 x 1325	
16	200	500	VB16CG	507/1006 x 1775	
20	200	600	VB20CG	507/1006 x 2225	
12+8	200	600	VB12+8CG	507/1006 x 1325	507/1006 x 2225
				507/1006 x 2225	

VB-CGE



VB-CGE is a series of vacuum lifters for curved glass with electric 360° continuous rotation and electric tilting system. They are available with 20 or 32 suction pads according to the load to lift. As all the movements are electric, radio remote control is included as standard. In order to safely and efficiently work on construction site, this series is equipped with a dual vacuum circuit and rechargeable on-board batteries.

VB-CGE 1100kg

Kg max 1100

Suction pads		Capacity Kg	Product code	Suction pads spread	
No.	Ø mm			mm	
12+8	200	600	VB12+8CGE	507/1006 x 1325	507/1006 x 2225
20	200	600	VB20CGE	507/1006 x 2225	
32	200	1100	VB32CGE	1780 x 1016	

Technical drawings

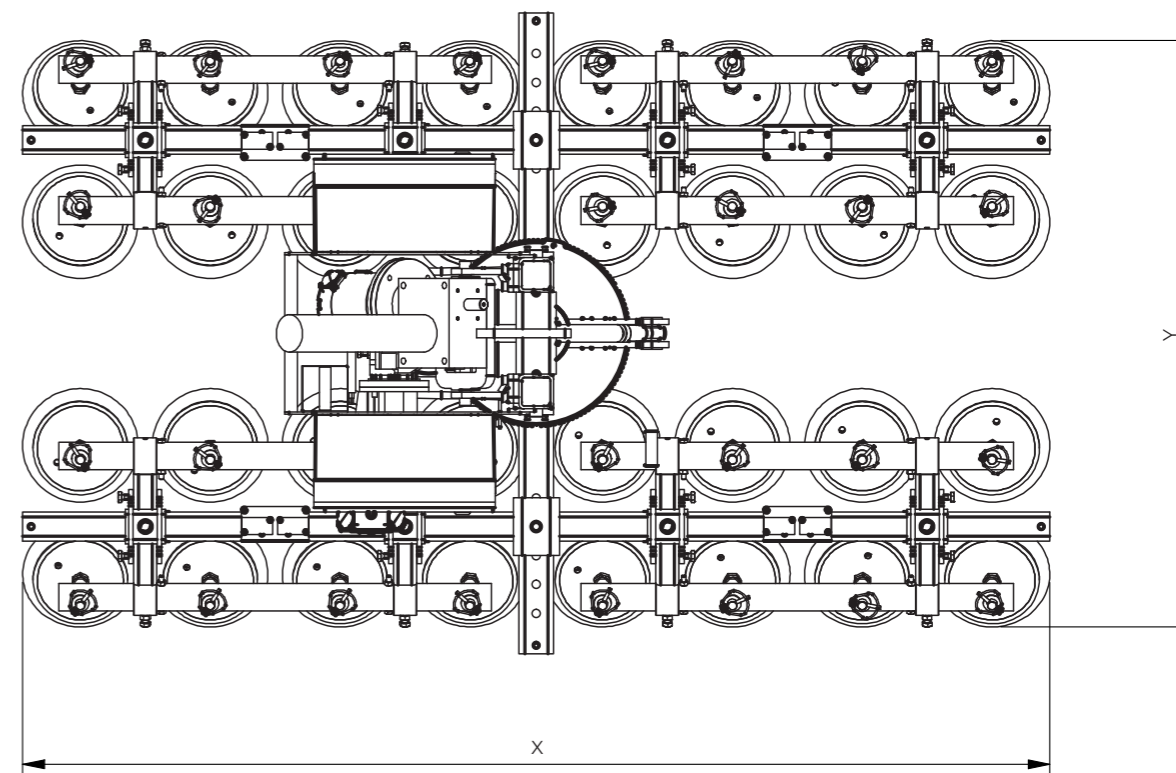

Suction pads for windscreen

Even though windshields may be counted as curved glass, they need to be handled differently. Indeed, their curvature radius is way smaller than actual curved glass panes yet considerable enough not to be lifted with standard flat suction pads.

This means that lifting car or boat windscreen might require specific handling and lifting equipment for an efficient work flux and a firm hold.

Righetti's R&D department has created vacuum lifters with suction pads specifically designed for lifting and handling windscreens.



Firm hold on all glass curvatures thanks to special suction pads specifically made for windscreens.



Transform your lifter in a curved glass vacuum lifter

During their work, glass installer might come across different shapes of glass panes: long and narrow, squared, small, large, and even curved.

In the latter case, using standard vacuum lifters may be sufficient when glass' bending angle is wide. However, as the radius of curvature becomes shorter, standard solutions won't adhere anymore correctly to the curved glass' surface.

To simplify installers' work, Righetti has therefore created a kit to transform your vacuum lifter in a VB-C model for curved glass. By removing the standard suction pads, installers can interchange them with dedicated arms equipped with suction pads for curved glass.

The arms can be placed in two different positions to adjust to both smaller and larger glasses.

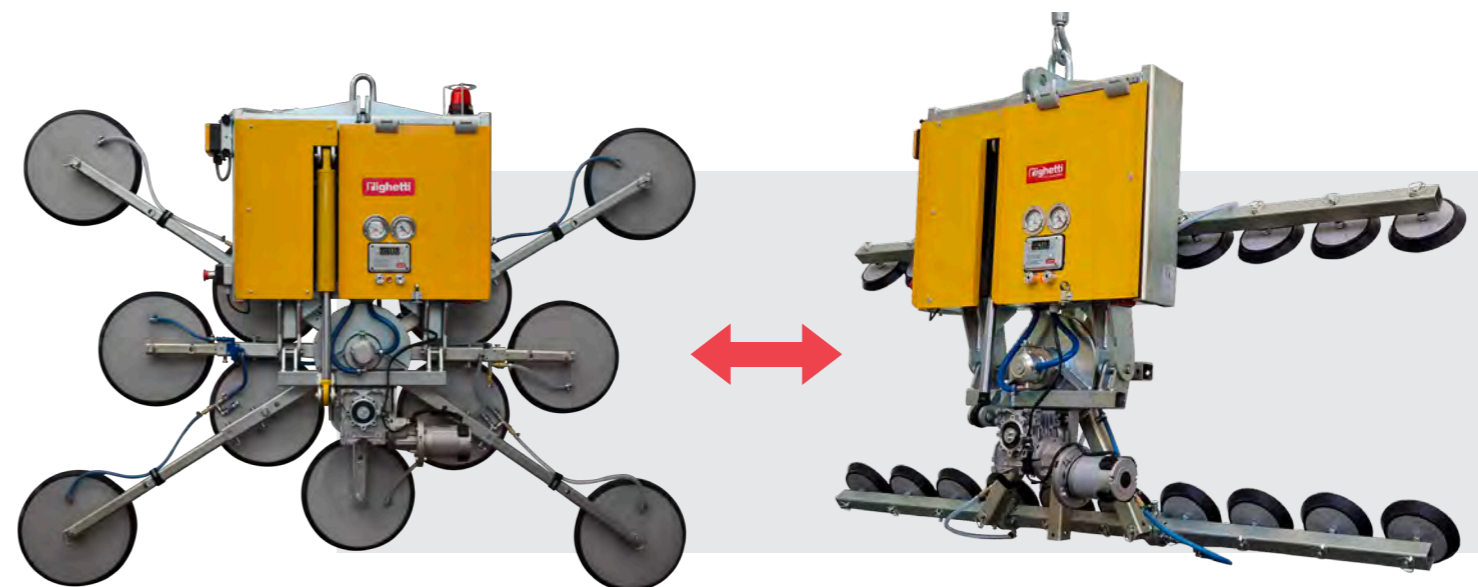
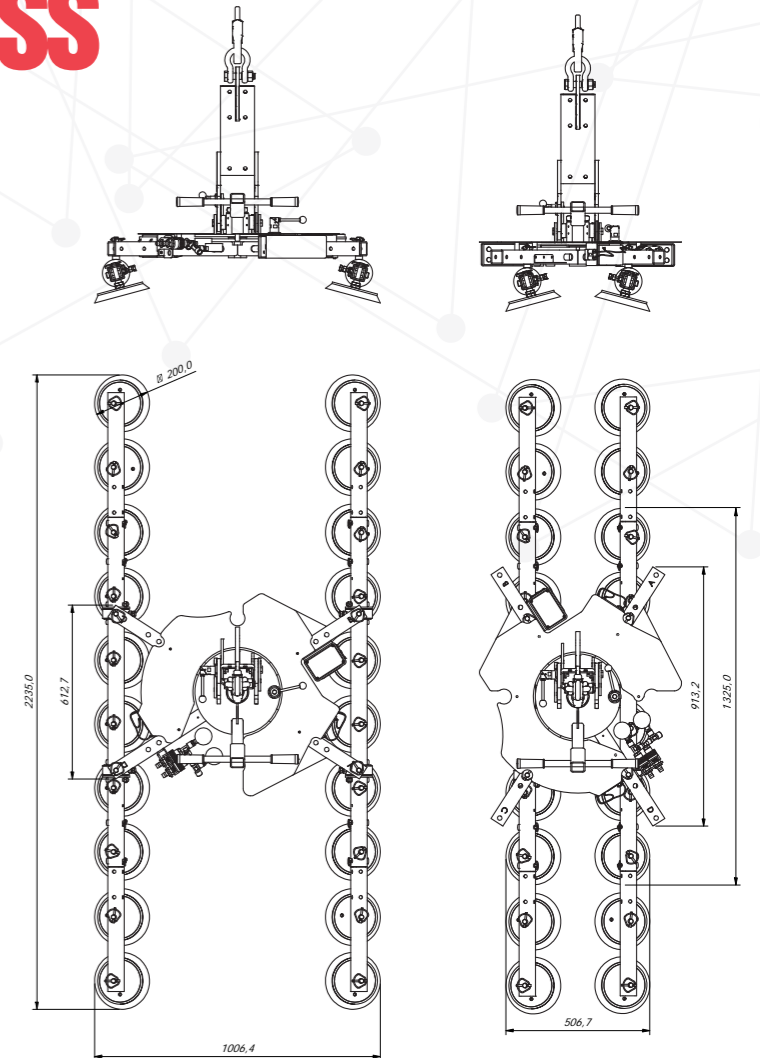



Righetti
smart vacuum lifters

Glass vacuum lifters
specifically for

production

Working in production environments requires specific vacuum lifters to satisfy all needs.

Glass vacuum lifters for production use hereby presented can be powered either by 220V single phase or 400V three-phase. Other voltages are available on request.

This line of products features manual tilt and rotation; moreover, it is equipped with a single vacuum circuit. Dual vacuum circuit is available on request to respect EN13155 for construction site use.

SUCTION PADS SPECIFIC FOR GLASS
equipped with a safety lip and rings, plus double spring system to compensate the flexion of the load

ELECTRIC VACUUM PUMP
available in two options: 220V single phase or 400V three phase

VISUAL AND ACOUSTIC ALARM
autonomously powered by built-in batteries

DUAL-ACTION OFF COMMAND
to safely control load suction and release

SINGLE VACUUM CIRCUIT AS STANDARD
while dual vacuum circuit is available on request for construction site use and for increasing safety

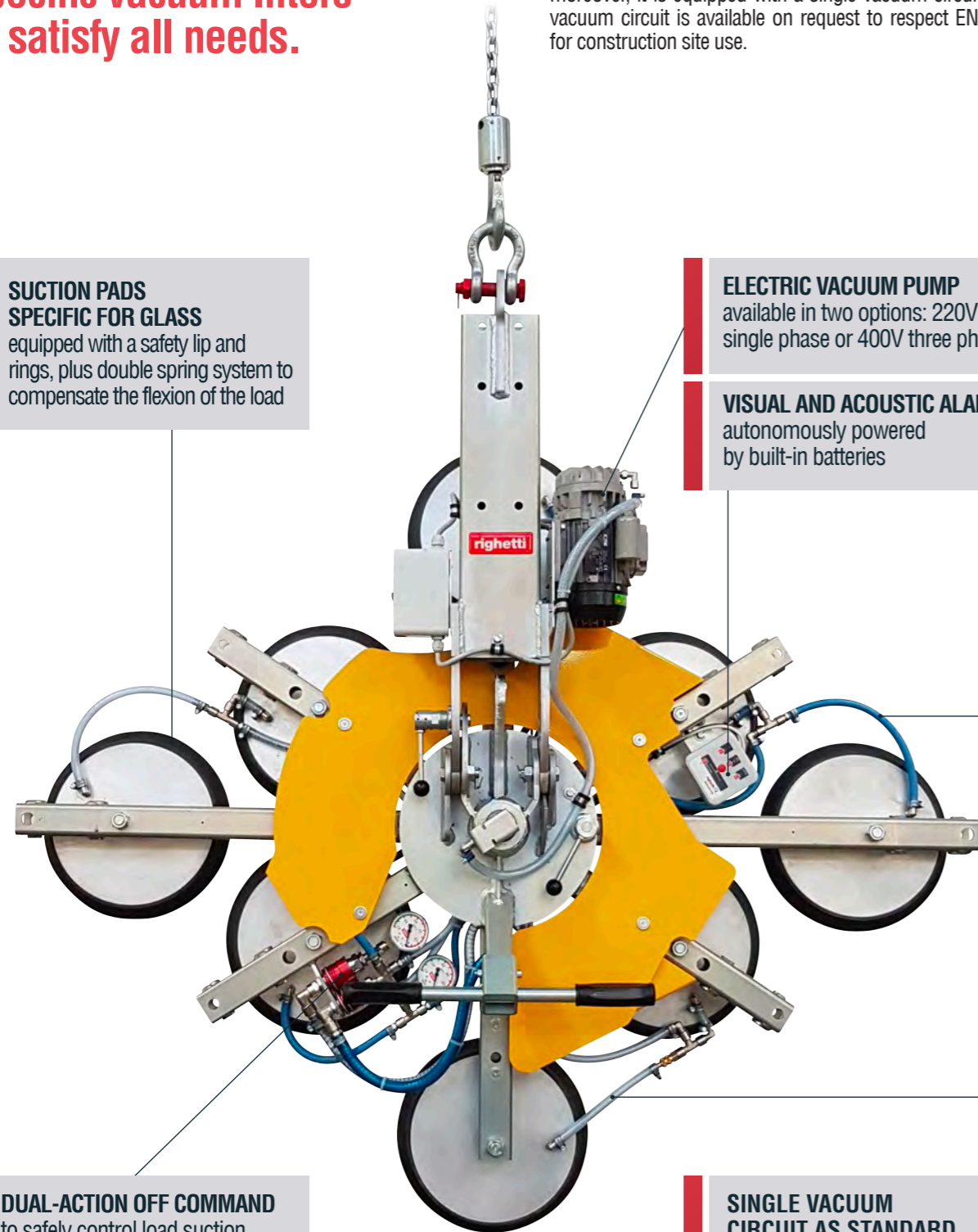

Glass vacuum lifters electrically powered with manual movements



Electrically powered



Manual Rotation 360°



Manual tilt 0-90°

Righetti
smart vacuum lifters

VEB2 RCMBM

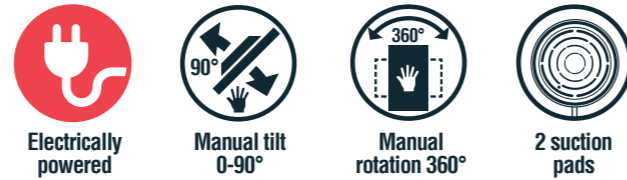
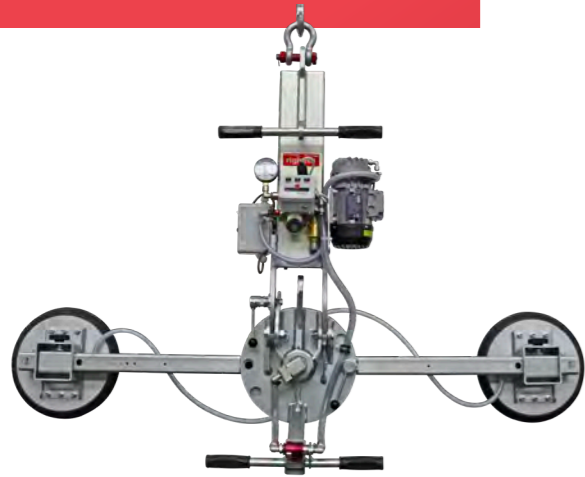

The VEB2 model is a vacuum glass lifter with two adjustable suction pads, perfect for lifting and handling small or narrow glass panels. VEB2 can be powered either by 220V single phase or 400V three-phase. The vacuum glass lifter VEB2 RCMBM has 0-90° tilt (horizontal / vertical), with possibility of automatic locking in upright and flat position and continuous 360° rotation, with possibility of automatic locking at each 90°. Dual vacuum system is available on request.

Suction pads		Capacity	Model with		Suction pads spread
No.	Ø mm	Kg	Single vacuum circuit	Dual vacuum circuit	mm
2	310	200	VEB2 RCMBM	VEBS2 RCMBM	810 x 310
					1660 x 310
2	390	300	VEB2 RCMBM d4	VEBS2 RCMBM d4	890 x 390
					1740 x 390

VEB4 RCMBM

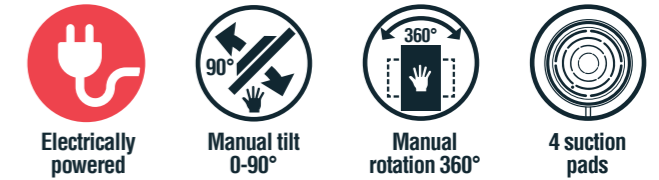
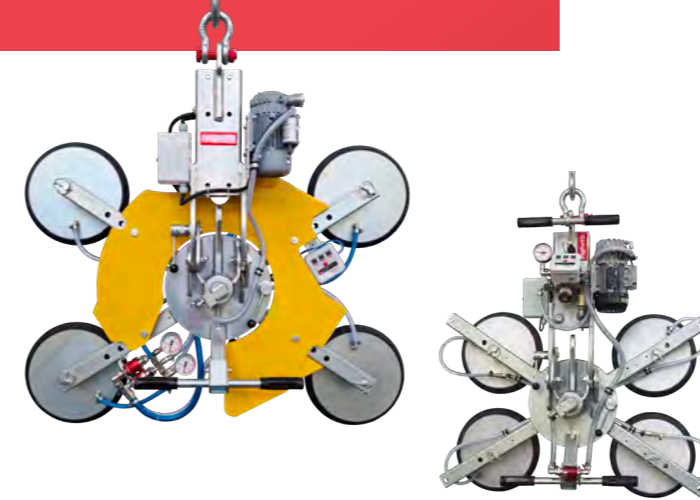

The VEB4 with manual movements has continuous 360° manual rotation and manual tilt. The operating-system can be powered either by 220V single phase or 400V three-phase. It is equipped by a single vacuum circuit, while dual vacuum circuit is available on request.

Suction pads		Capacity	Model with		Suction pads spread
No.	Ø mm	Kg	Single vacuum circuit	Dual vacuum circuit	mm
4	310	400	VEB4 RCMBM	VEBS4 RCMBM	863 x 666
					1166 x 861
					1019 x 795
4	390	600	VEB4 RCMBM d4	VEBS4 RCMBM d4	1246 x 941

VEB4L RCMBM

The VEB4L is a below-the-hook vacuum glass lifter suitable for lifting and handling of long and narrow glass panes. Its four-in-line configuration permits to lift glass with dimension from 32 cm. Vacuum glass lifter VEB4L RCMBM is powered either by 220V single phase or 400V three-phase. It is equipped with a single vacuum circuit, while dual vacuum circuit is available on request.

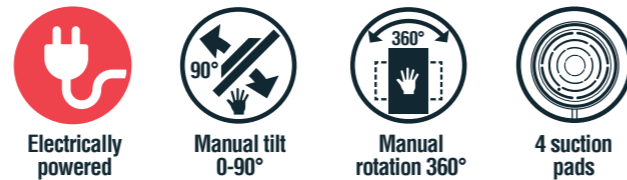

Suction pads		Capacity	Model with		Suction pads spread
No.	Ø mm	Kg	Single vacuum circuit	Dual vacuum circuit	mm
4	310	400	VEB4L RCMBM	VEBS4L RCMBM	1660 x 310
4	390	600	VEB4L RCMBM d4	VEBS4L RCMBM d4	1740 x 390

VEB4 RCMBM PRO

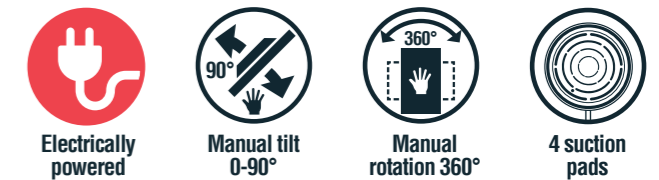
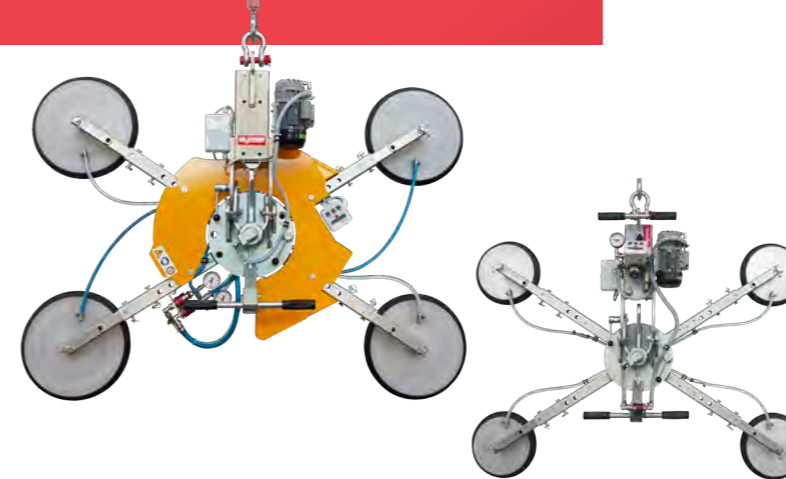

VEB4 PRO is the upgraded glass vacuum lifter of the standard VEB4. Its 4 adjustable suction pads allow you to create several configurations for a safe handling of small glass, large panes, and long and narrow panes. Thanks to its modularity, VEB4 PRO gives you huge flexibility. This model is equipped with a single vacuum circuit, while dual vacuum circuit is available on request.

Suction pads		Capacity	Model with		Suction pads spread
No.	Ø mm	Kg	Single vacuum circuit	Dual vacuum circuit	mm
4	310	400	VEB4 RCMBM PRO	VEBS4 RCMBM PRO	863 x 666
					1166 x 861
					1535 X 1100
					1770 X 310
4	390	600	VEB4 RCMBM d4 PRO	VEBS4 RCMBM d4 PRO	1019 x 795
					1246 x 941
					1630 x 1190
					1870 x 390

VEB6 RCMBM

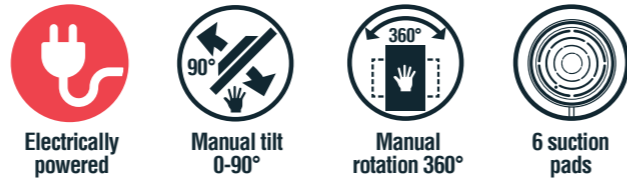
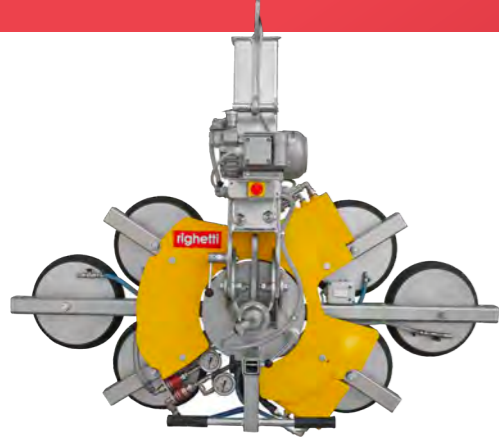

The VEB6 is 6 pads vacuum lifter with manual 360° continuous rotation and manual tilting system 0-90°. The electrically-operated system can be powered either by 220V single phase or 400V three-phase. This model is equipped with a single vacuum circuit, while dual vacuum circuit is available on request.

The picture shows a dual vacuum circuit model

Suction pads		Capacity	Model with		Suction pads spread
No.	Ø mm	Kg	Single vacuum circuit	Dual vacuum circuit	mm
6	310	600	VEB6 RCMBM	VEBS6 RCMBM	1420 x 678
6	390	900	VEB6 RCMBM d4	VEBS6 RCMBM d4	1810 x 830

VEB8 RCMBM

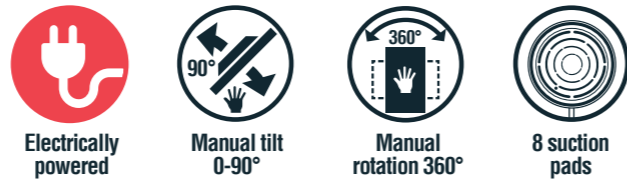
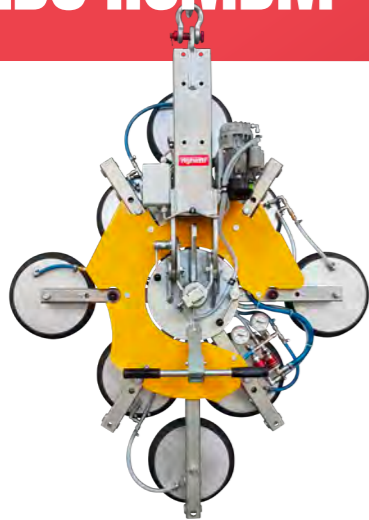

The VEB8 is a below-the-hook vacuum glass lifter suitable for lifting and handling of glass units weighing up to 1200 kg. Vacuum glass lifter VEB8 RCMBM is powered either by 220V single phase or 400V three-phase. The VEB8 RCMBM vacuum lifter features manual tilt and manual 360 degree rotation with possibility of automatic stop or continuous rotation. This model is equipped with a single vacuum circuit, while dual vacuum circuit is available on request.

The picture shows a dual vacuum circuit model

Suction pads		Capacity	Model with		Suction pads spread
No.	Ø mm	Kg	Single vacuum circuit	Dual vacuum circuit	mm
8	310	800	VEB8 RCMBM	VEBS8 RCMBM	1420 x 970
8	390	1200	VEB8 RCMBM d4	VEBS8 RCMBM d4	1810 x 1360

VEB4+4 RCMBM

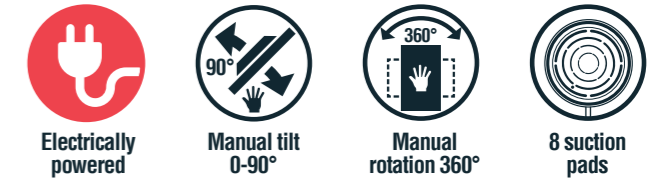

VEB4+4 is a glass vacuum lifter that offers you wide flexibility. This model is equipped with 4 fixed suction pads, plus 4 external suction pads placed on removable extension arms. By adding or removing the arms, you can increase or decrease the lifting capacity and pad spread of the vacuum lifter. This model is equipped with a single vacuum circuit, while dual vacuum circuit is available on request.

The picture shows a single vacuum circuit model

Suction pads	Capacity	Model with	Configurations		Suction pads spread		
			Pads in use	Capacity			
No.	Ø mm	Kg	Single vacuum circuit	Dual vacuum circuit	mm		
8	310	800	VEB4+4 RCMBM	VEBS4+4 RCMBM	4	400	863 x 666
					4+4	800	1700 x 1210
					4+4	800	2145 x 1488
8	390	1200	VEB4+4 RCMBM d4	VEBS4+4 RCMBM d4	4	600	1019 x 795
					4+4	1200	1780 x 1290
					4+4	1200	2248 x 1596
					4+4	1200	2248 x 1596

VEB4+4 RCMBM XL

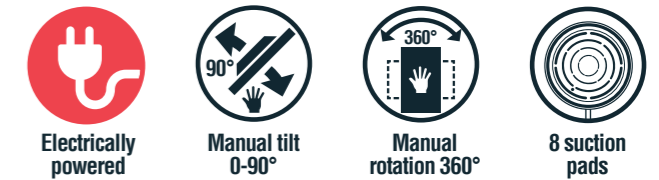
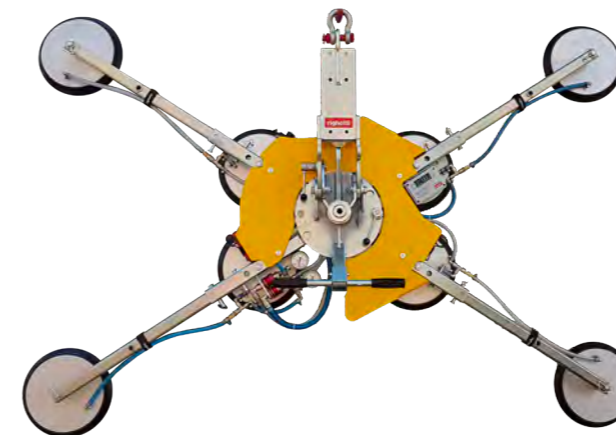

VEB4+4 XL is the top-of-the-range model among the electric vacuum lifters thanks to its extreme modularity. This lifting equipment can be adapted in several configurations to adjust to all glass shapes and sizes. Each configuration has a different lifting capacity, which should match with the load to be lifted. 0-90° tilting and 360° continuous rotation are manually performed.

The picture shows a dual vacuum circuit model

Suction pads	Capacity	Model with	Configurations		Suction pads spread		
			Pads in use	Capacity			
No.	Ø mm	Kg	Single vacuum circuit	Dual vacuum circuit	mm		
8	310	800	VEB4+4 RCMBM XL	VEBS4+4 RCMBM XL	4	400	863 x 666
					4+4	800	2145 x 1488
					4+2	600	2430 x 715
					4 in line	400	2530 x 310
8	390	1200	VEB4+4 RCMBM d4 XL	VEBS4+4 RCMBM d4 XL	2	200	970 x 310
					4	600	1019 x 795
					4+4	1200	2248 x 1596
					4+2	900	2510 x 800
					4 in line	600	2610 x 390
					2	300	1150 x 390

Glass vacuum lifters for production use can be powered either by 220V single phase or 400V three-phase.

Models hereby presented are equipped with powered tilt and rotation, but Righetti offers the choice of just one or both electrically powered movements.
Electrically powered vacuum lifters feature as standard a dual vacuum circuit .

ELECTRIC VACUUM PUMP
available in two options: 220V single phase or 400V three phase

VISUAL AND ACOUSTIC ALARM
autonomously powered by built-in batteries

DUAL-ACTION OFF COMMAND
to safely control load suction and release

POWERED MOVEMENTS
tilt and rotation can be both powered, or the client can choose just one electric movement

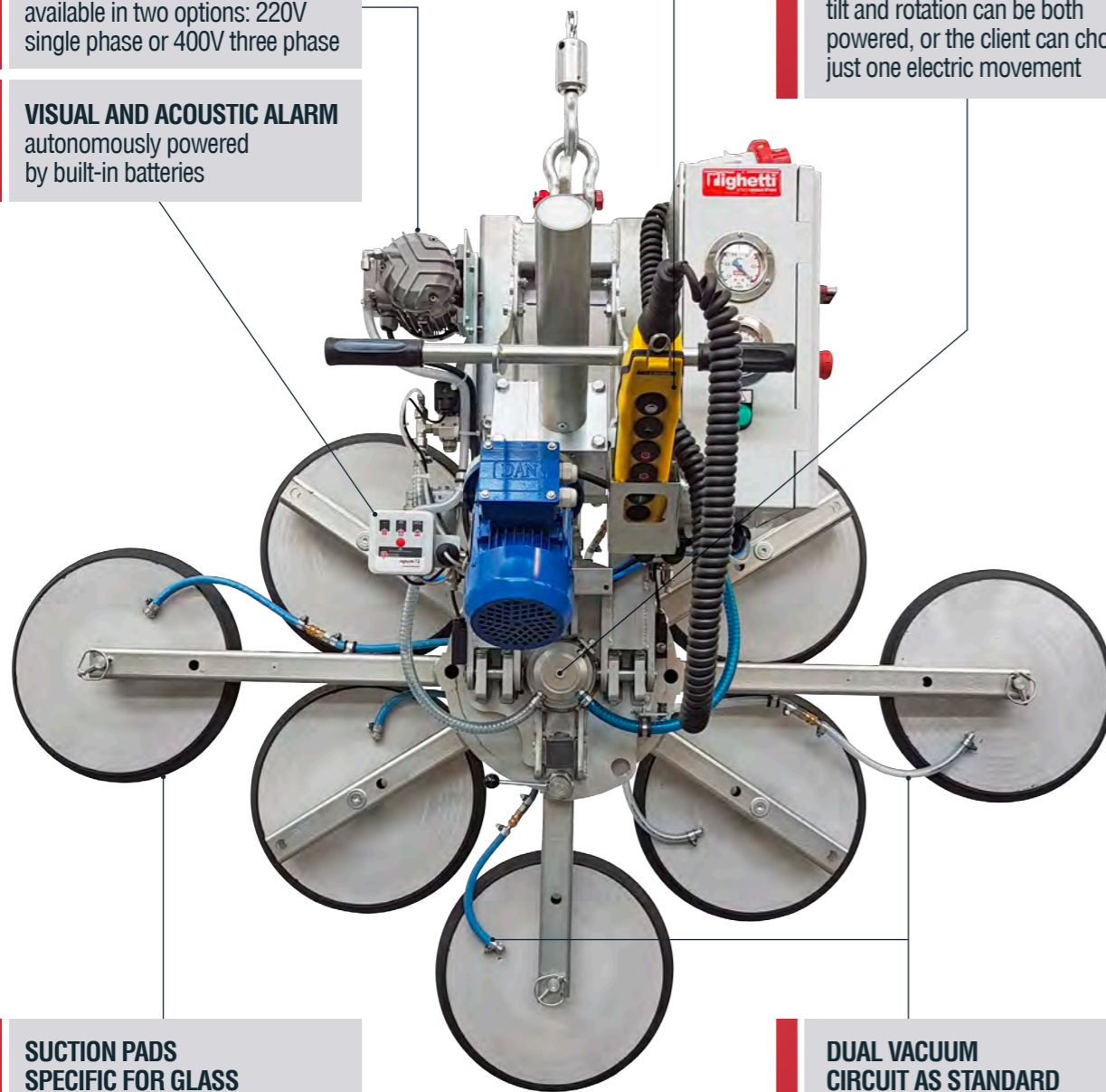

SUCTION PADS SPECIFIC FOR GLASS
equipped with a safety lip and rings, plus double spring system to compensate the flexion of the load

DUAL VACUUM CIRCUIT AS STANDARD
which make it possible to occasionally use the vacuum lifter on construction site

Glass vacuum lifters electrically powered with electric movements



Electrically powered



Electric Rotation 360°



Electric tilt 0-90°

Righetti
smart vacuum lifters

VEB2 RCEBE



Electrically powered



Electric tilt 0-90°



Electric rotation 360°



2 suction pads



Dual vacuum circuit

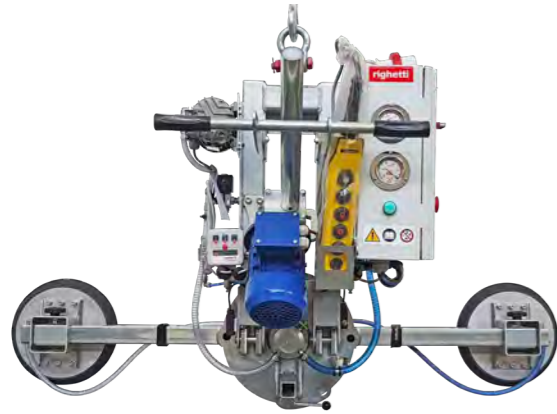

The VEB2 RCEBE model is a vacuum glass lifter with two adjustable suction pads, perfect for lifting and handling small or narrow glass panels. VEB2 RCEBE can be powered either by 220V single phase or 400V three-phase. It can be equipped with manual tilt and electric rotation, electric tilt and manual rotation, or both electric movements.

Suction pads		Capacity	Model with			Suction pads spread
No.	Ø mm	Kg	electric tilt and electric rotation	manual tilt and electric rotation	electric tilt and manual rotation	mm
2	310	200	VEB2 RCEBE	VEB2 RCEBM	VEB2 RCMBE	810 x 310
						1660 x 310
2	390	300	VEB2 RCEBE d4	VEB2 RCEBM d4	VEB2 RCMBE d4	890 x 390
						1740 x 390

VEB4 RCEBE



Electrically powered



Electric tilt 0-90°



Electric rotation 360°



4 suction pads



Dual vacuum circuit



The VEB4 RCEBE with electric movements is an electrically-powered vacuum lifter whose operating-system can be powered either by 220V single phase or 400V three-phase. Beside both electric movements, it can be equipped with manual tilt and electric rotation, or electric tilt and manual rotation.

This model is also available in VEB4 RCEBE PRO version

Suction pads		Capacity	Model with			Suction pads spread
No.	Ø mm	Kg	electric tilt and electric rotation	manual tilt and electric rotation	electric tilt and manual rotation	mm
4	310	400	VEB4 RCEBE	VEB4 RCEBM	VEB4 RCMBE	863 x 666
						1166 x 861
4	390	600	VEB4 RCEBE d4	VEB4 RCEBM d4	VEB4 RCMBE d4	1019 x 795
						1246 x 941

VEB4L RCEBE



Electrically powered



Electric tilt 0-90°



Electric rotation 360°



4 suction pads



Dual vacuum circuit



The VEB4L RCEBE is an electrically-powered vacuum lifter with 4 suction cups in a row. It can lift up to 400 kg or 600 kg. It can be equipped with manual tilt and electric rotation, electric tilt and manual rotation, or both electric movements. The aspiration, release and electric movements commands are controlled by wireless radio remote control.

Suction pads		Capacity	Model with			Suction pads spread
No.	Ø mm	Kg	electric tilt and electric rotation	manual tilt and electric rotation	electric tilt and manual rotation	mm
4	310	400	VEB4L RCEBE	VEB4L RCEBM	VEB4L RCMBE	1660 x 310
4	390	600	VEB4L RCEBE d4	VEB4L RCEBM d4	VEB4L RCMBE d4	1740 x 390

VEB4X RCEBE



Electrically powered



Electric tilt 0-90°



Electric rotation 360°



4 suction pads



Dual vacuum circuit

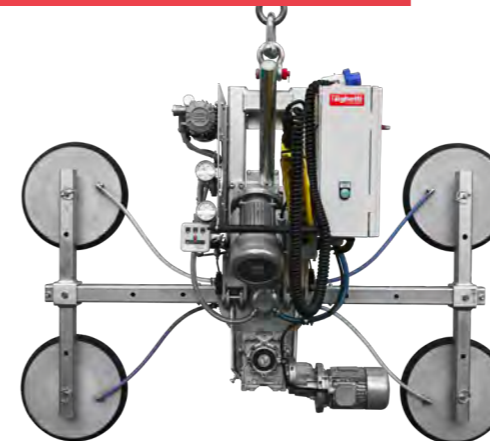

VEB4X RCEBE is the crossed-arms configuration of standard VEB4. It is equipped with electric rotation and tilting system. Load release and aspiration can be made by using the pushbutton wired control.

Suction pads		Capacity	Model with			Suction pads spread
No.	Ø mm	Kg	electric tilt and electric rotation	manual tilt and electric rotation	electric tilt and manual rotation	mm
4	310	400	VEB4X RCEBE	VEB4X RCEBM	VEB4X RCMBE	850 x 750
						1660 x 1000
4	390	600	VEB4X RCEBE d4	VEB4X RCEBM d4	VEB4X RCMBE d4	950 x 850
						1760 x 1100

VEB6 RCEBE



Electrically powered



Electric tilt 0-90°



Electric rotation 360°



6 suction pads



Dual vacuum circuit

The VEB6 RCEBE is 6-pads electric vacuum lifter. The electrically-operated system can be powered either by 220V single phase or 400V three-phase. The VEB6 RCEBE vacuum lifter can combine manual tilt and electric rotation, electric tilt and manual rotation or both electric movements.

Suction pads		Capacity	Model with			Suction pads spread
No.	Ø mm	Kg	electric tilt and electric rotation	manual tilt and electric rotation	electric tilt and manual rotation	mm
6	310	600	VEB6 RCEBE	VEB6 RCEBM	VEB6 RCMBE	1420 x 678
6	390	900	VEB6 RCEBE d4	VEB6 RCEBM d4	VEB6 RCMBE d4	1810 x 830

VEB4+4 RCEBE

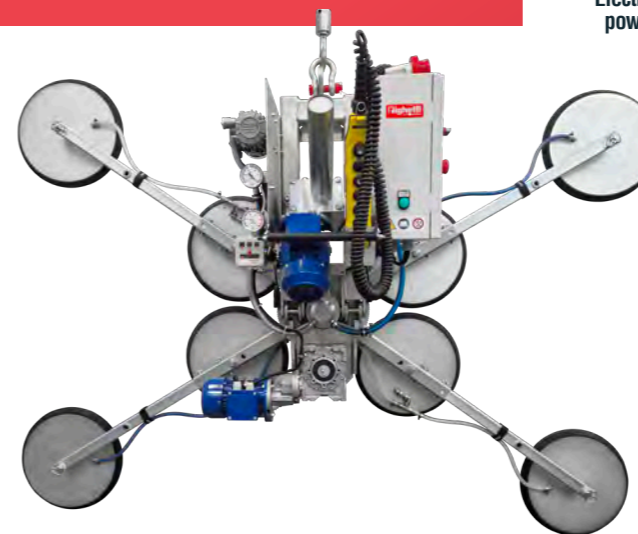

Electrically powered



Electric tilt 0-90°



Electric rotation 360°



8 suction pads



Dual vacuum circuit

VEB4+4 RCEBE is an electrically-operated glass vacuum lifter that offers you wide flexibility. This model is equipped with 4 fixed suction pads, plus 4 external suction pads placed on removable extension arms. By adding or removing the arms, you can increase or decrease the lifting capacity and pad spread of the vacuum lifter.

Suction pads		Capacity	Model with			Configurations		Suction pads spread
No.	Ø mm	Kg	electric tilt and electric rotation	manual tilt and electric rotation	electric tilt and manual rotation	Pads in use	Conf. capacity	mm
8	310	800	VEB4+4 RCEBE	VEB4+4 RCEBM	VEB4+4 RCMBE	4	400	863 x 666
						4+4	800	1700 x 1210
						4+4	800	2145 x 1488
8	390	1200	VEB4+4 RCEBE d4	VEB4+4 RCEBM d4	VEB4+4 RCMBE d4	4	600	1019 x 795
						4+4	1200	1780 x 1290
						4+4	1200	2248 x 1596

VEB8 RCEBE

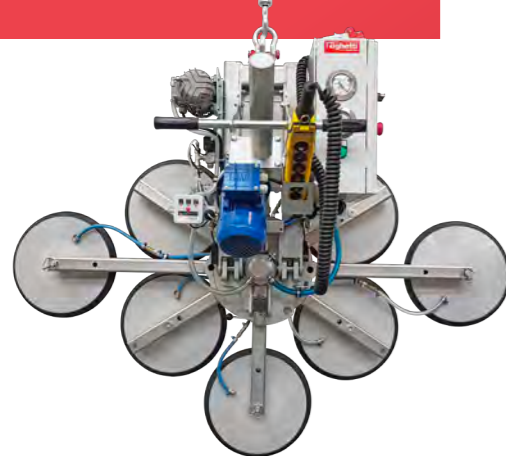

Electrically powered



Electric tilt 0-90°



Electric rotation 360°



8 suction pads



Dual vacuum circuit

The VEB8 RCEBE is a vacuum glass lifter suitable for lifting and handling of glass units weighing up to 1200 kg. Vacuum glass lifter VEB8 is powered either by 220V single phase or 400V three-phase. It can combine manual tilt and electric rotation, electric tilt and manual rotation or both electric movements. All the electric movements, as well as aspiration and release, are controlled by a pushbutton cable controller.

Suction pads		Capacity	Model with			Suction pads spread
No.	Ø mm	Kg	electric tilt and electric rotation	manual tilt and electric rotation	electric tilt and manual rotation	mm
8	310	800	VEB8 RCEBE	VEB8 RCEBM	VEB8 RCMBE	1420 x 970
8	390	1200	VEB8 RCEBE d4	VEB8 RCEBM d4	VEB8 RCMBE d4	1810 x 1360

VEB4+4 RCEBE XL



Electrically powered



Electric tilt 0-90°



Electric rotation 360°



8 suction pads



Dual vacuum circuit

VEB4+4 RCEBE XL is one of the most modular vacuum lifters among the electric series. Its frame can be adjusted in several configurations and alignments in order to adapt to the different sizes and shapes of the glass. Small, large, long or narrow glass sheets can be all handled by VEB4+4 XL.

Suction pads		Capacity	Model with			Configurations		Suction pads spread
No.	Ø mm	Kg	electric tilt and electric rotation	manual tilt and electric rotation	electric tilt and manual rotation	Pads in use	Capacity	mm
8	310	800	VEB4+4 RCEBE	VEB4+4 RCEBM	VEB4+4 RCMBE	4	400	863 x 666
						4+4	800	2145 x 1488
						4+2	600	2430 x 715
						4 in line	400	2530 x 310
						2	200	970 x 310
8	390	1200	VEB4+4 RCEBE d4	VEB4+4 RCEBM d4	VEB4+4 RCMBE d4	4	600	1019 x 795
						4+4	1200	2248 x 1596
						4+2	900	2510 x 800
						4 in line	600	2610 x 390
						2	300	1150 x 390

Vacuum lifters powered by compressed air are ideal to use on a jib crane or other pneumatic lifting means.

The hereby presented models can be customized to satisfy all needs: Righetti vacuum lifters can feature a combination of manual and pneumatic movements.

Moreover, they can have different lifting capacities and configurations to adapt to all loads. Besides the models mentioned in this catalogue, Righetti can design and create any other vacuum lifter on request.

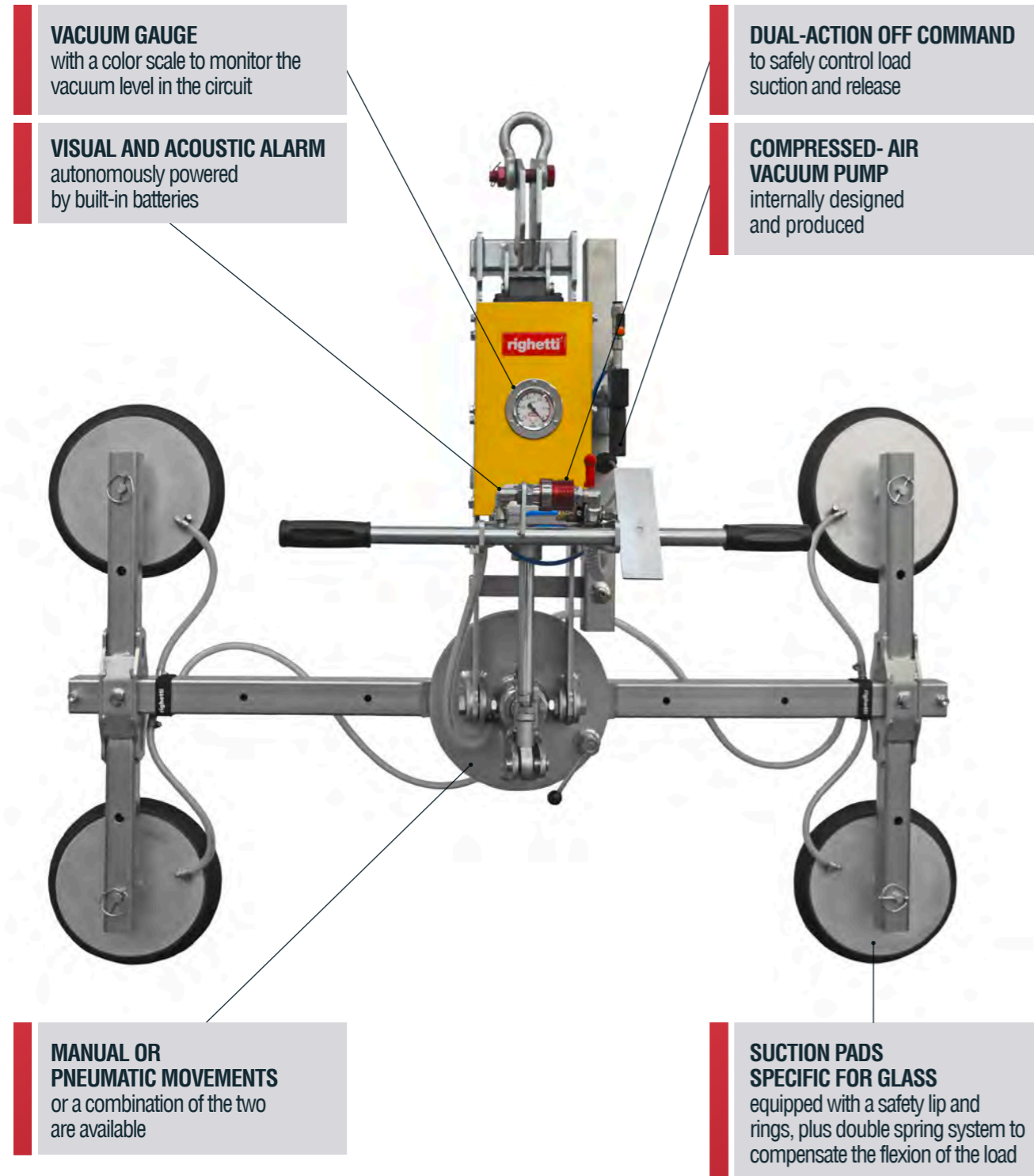

Glass vacuum lifters

compressed air operated



Compressed air



Manual rotation 360°

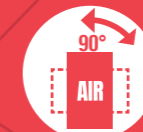

Pneumatic rotation 90°



Pneumatic tilt 0-90°



Manual tilt 0-90°

VA-RCM



The VA-RCM Series includes pneumatic vacuum lifters with continuous 360° manual rotation. Its structure is fixed in vertical. The vacuum lifter can be equipped with two, four or eight suction pads depending on the load to lift.

Suction pads		Capacity Kg	Product code	Suction pads spread	
No.	Ø mm			mm	
2	310	200	VA2RCM	810 x 310	1660 x 310
				810 x 750	1660 x 1000
4	310	400	VA4RCM	1660 x 1000	2600 x 1000
8	310	800	VA8RCM	2600 x 1000	

VA-RCMBP

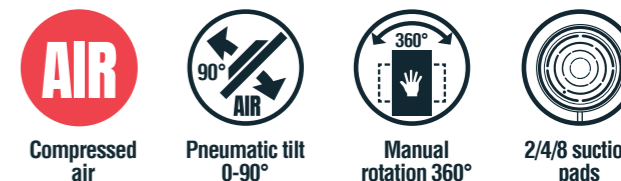

The VA-RCMBP series includes pneumatic vacuum lifters with continuous 360° manual rotation and 90° pneumatic tilt. The vacuum lifter can be equipped with two, four or eight suction pads depending on the load to lift.

Suction pads		Capacity Kg	Product code	Suction pads spread	
No.	Ø mm			mm	
2	310	200	VA2RCMBP	810 x 310	1660 x 310
				810 x 750	1660 x 1000
4	310	400	VA4RCMBP	1660 x 1000	2600 x 1000
8	310	800	VA8RCMBP	2600 x 1000	

VA-RCMBM

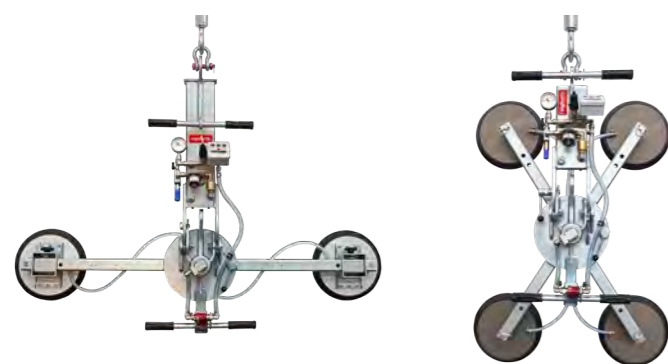
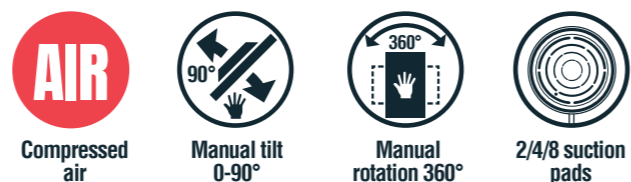

The VA-RCMBM series includes pneumatic vacuum lifters with continuous 360° manual rotation and manual tilt. The tilting system allows to manually tilt the vacuum lifter from vertical to horizontal position (and viceversa). The vacuum lifter can be equipped with two, four or eight suction pads depending on the load to lift.

Suction pads		Capacity Kg	Product code	Suction pads spread	
No.	Ø mm			mm	
2	310	200	VA2RCMBM	810 x 310	1660 x 310
				810 x 750	1660 x 1000
4	310	400	VA4RCMBM	1660 x 1000	2600 x 1000
8	310	800	VA8RCMBM	2600 x 1000	

VA4 RCMBP-R

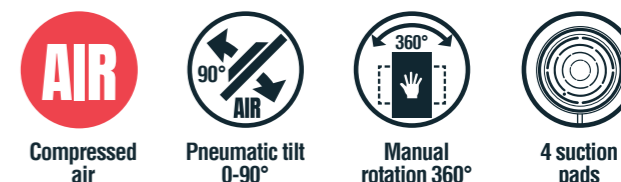

The VA4 RCMBP-R is a pneumatic vacuum lifters with continuous 360° manual rotation and 90° pneumatic tilt. What makes this model different is the possibility of rotating the arms too. Thanks to this feature, its 4 suction pads can be moved from a crossed configuration to an in-line one.

Suction pads		Capacity Kg	Product code	Configurations Pads in use	Suction pads spread	
No.	Ø mm				mm	
4	310	400	VA4RCMBP-R	4 (crossed)	1115 x 920	1265 x 920
					1415 x 920	2025 x 310
					4 (in-line)	

VA-RP



The VA-RP series includes pneumatic vacuum lifters with 90° pneumatic rotation. Its frame is fixed in vertical position. The vacuum lifter can be equipped with two or four suction pads depending on the load to lift. This series can be built also with telescopic arms on request (VA2T-RP).

Suction pads		Capacity Kg	Product code	Suction pads spread
No.	Ø mm			mm
2	310	200	VA2RP	660 x 310
			VA2TRP	1570 x 350
4	310	400	VA4RP	1660 x 1000

VA-RPBP



The VA-RPBP series includes pneumatic vacuum lifters with 90° pneumatic rotation and pneumatic tilt. The vacuum lifter can be equipped with two or four suction pads depending on the load to lift.

Suction pads		Capacity Kg	Product code	Suction pads spread
No.	Ø mm			mm
2	310	200	VA2RPBP	830 x 350
4	310	400	VA4RPBP	1660 x 1000

VA2+2T-RP/TH

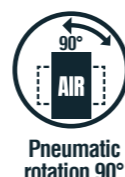

VA2+2T-RP/TH is a pneumatic vacuum lifter with 90° pneumatic rotation fixed in vertical position. It is equipped with two fixed pads, plus two extra pads placed on removable extension arms. Its modularity allows the handling of small, long or medium glass panes with just one vacuum lifter. All the commands are placed on the telescopic handle.

Suction pads		Capacity Kg	Product code	Configurations	Suction pads spread
No.	Ø mm			Pads in use	mm
4	310	400	VA2+2T-RP/TH	2	650 x 310
				4 (in-line)	1321 x 310
				4 (in-line telescopic)	2201 x 310

VA-BP



The VA-BP series includes pneumatic vacuum lifters whose only movement is its 90° pneumatic tilt, which is effortlessly executed by one or two cylinders. The vacuum lifter can be equipped with two, four or eight suction pads depending on the load to lift.

Suction pads		Capacity Kg	Product code	Suction pads spread
No.	Ø mm			mm
2	310	200	VA2BP	970 x 310 1700 x 310
4	310	400	VA4BP	970 x 750 1700 x 1000
8	310	800	VA8BP	2600 x 1000

R1

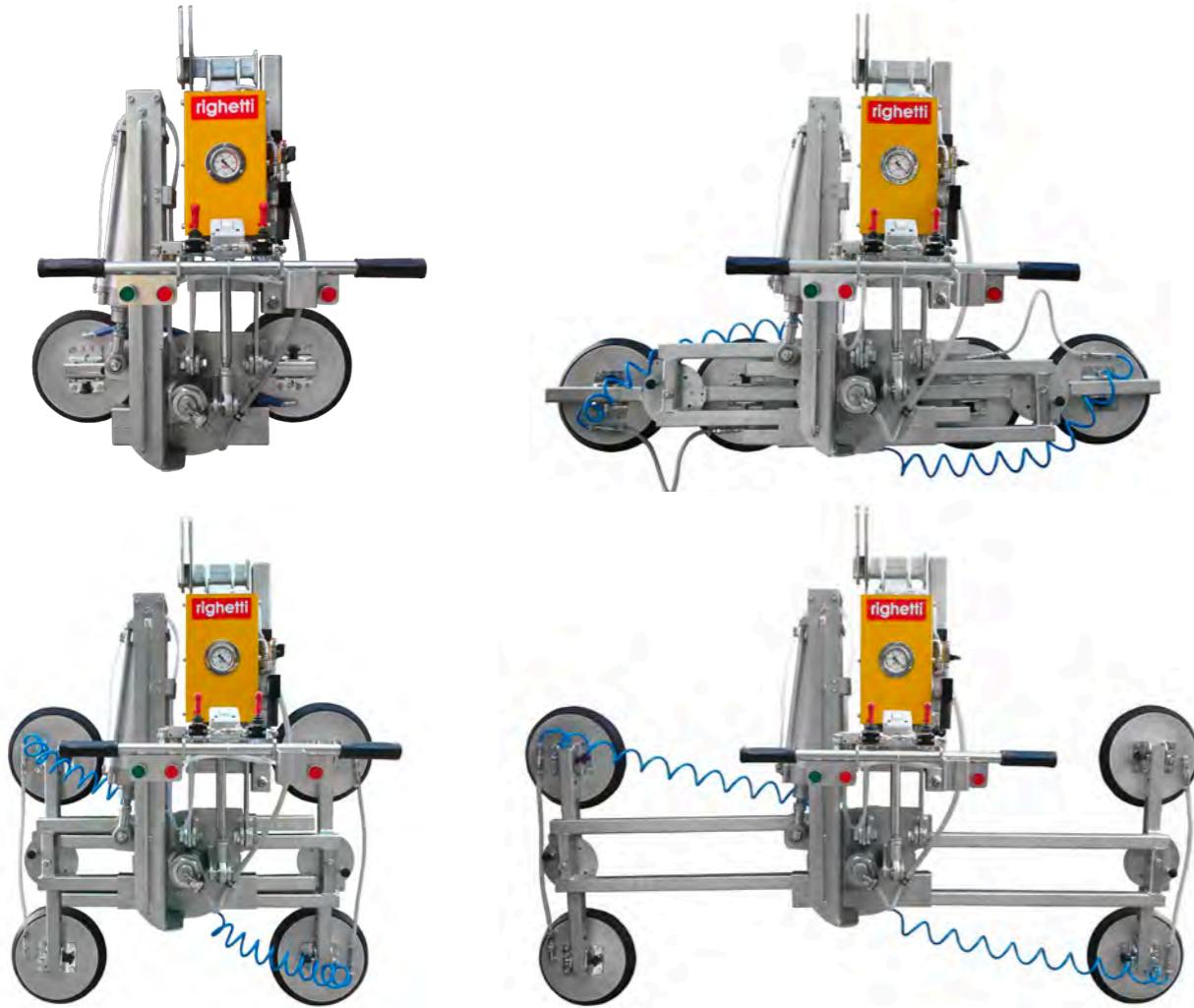
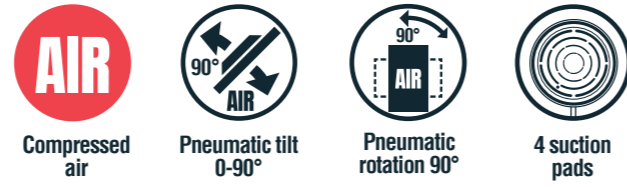

R1 is a pneumatic vacuum lifter with modular frame. Its suction pads and arms are easily adjustable and removable in order to make it easy to handle glass panes of various sizes. Its rotation and tilt are powered by compressed-air and can be controlled via the buttons positioned on the handle.

Suction pads		Capacity	Product code	Configurations	Suction pads spread
No.	Ø mm	Kg		Pads in use	mm
4	310	400	R1	2	850 x 310
				4 (in-line)	1780 x 310
					2030 x 310
					2480 x 310
				4	1130 x 670
1880 x 920					



Vacuum lifters with vertically fixed frame are ideal for handling large glass panes that do not require tilt or rotation.

These models can be powered either by compressed air or electricity, depending on the needs.

The wide frame of vertically fixed vacuum lifters assures firm support to the entire length of the glass panes. For extra safety, the vacuum lifter can be equipped with a protection guard.

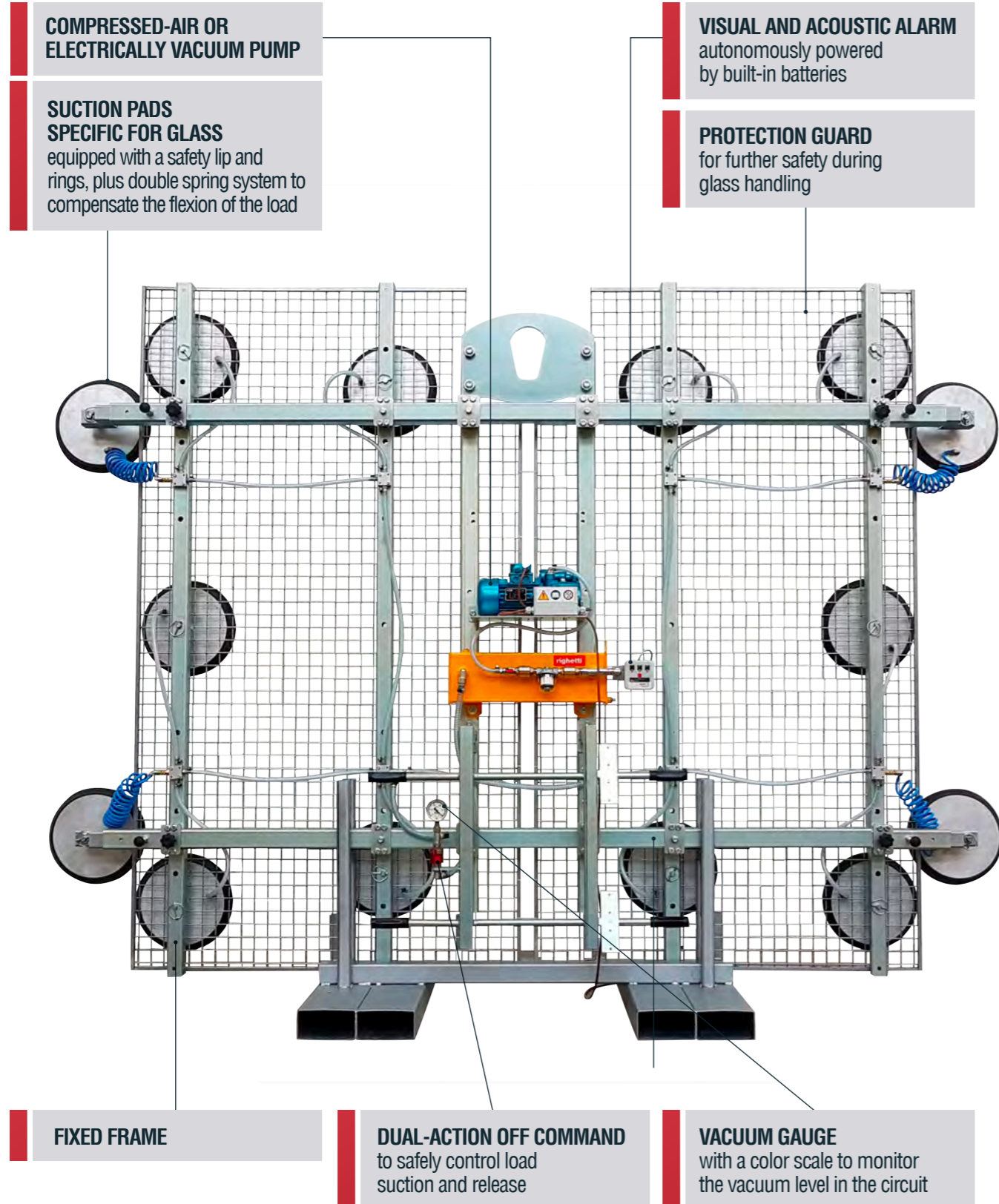

Glass vacuum lifters

with vertically fixed frame



VEB-FV/VA-FV



Vacuum lifters with fixed structure are suitable for handling large glass panes only in vertical position. The frame of these vacuum lifters assure enough support to the entire glass pane. These models can be powered either by compressed air (VA-FV series) or by an electric operating system (VEB-FV). The number of suction pads goes from 6 to 16, depending on the load to lift. The maximum lifting capacity reaches up to 1600kg.

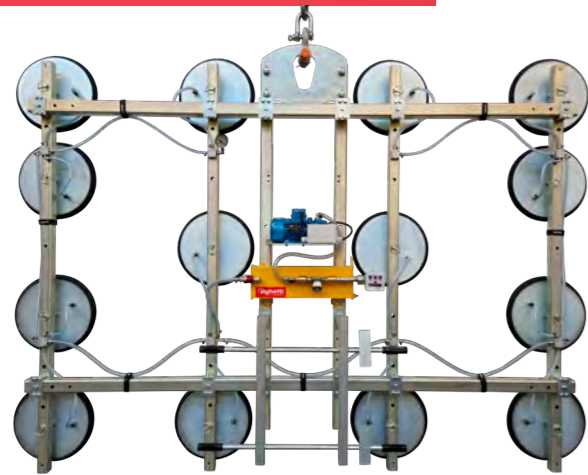

Suction pads		Capacity Kg	Model with	
No.	Ø mm		Electric operating system	Air-powered system
6	310	600	VEB6-FV	VA6-FV
8	310	800	VEB8-FV	VA8-FV
10	310	1000	VEB10-FV	VA10-FV
12	310	1200	VEB12-FV	VA12-FV
14	390	1600	VEB14d4-FV	VA14d4-FV
10+4	310	1400	VEB10+4T-FV	VA10+4T-FV
12+4	310	1600	VEB12+4T-FV	VA12+4T-FV

VEB-L-FV



VEB-L-FV is an electrically operated vacuum lifter whose frame is vertically fixed. Its length can be adjusted with 2, 4 or 6 in-line suction pads depending on the load to handle. This model can be powered wither by 220V single phase or 400V three-phase, but other operating systems are available on request.

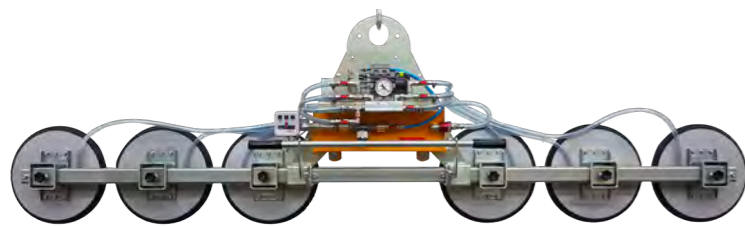

Suction pads		Capacity Kg	Product code	Suction pads spread
No.	Ø mm			mm
2		350	VEB2L-FV	1240 x 390
4		650	VEB4L-FV	2060 x 390
6		1000	VEB6L-FV	2880 x 390

OPTIONAL

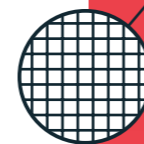
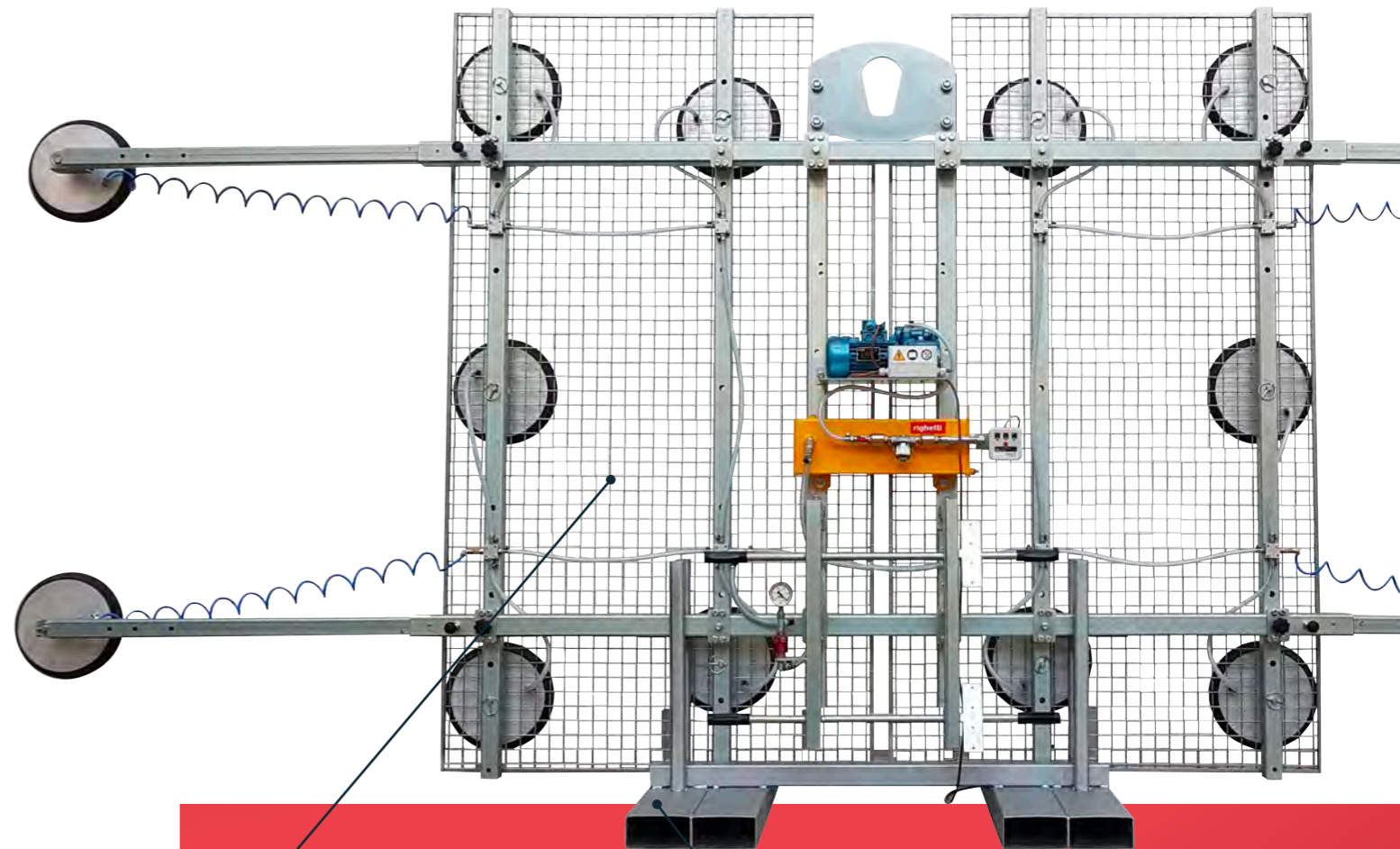

Metallic protection guard

To further protect the operators during glass handling, the vacuum lifter's frame can be equipped with a metallic net guard.



Forkable parking stand

Beside the basic parking stand, the vacuum lifters can be parked in a forkable stand which make transport easier and faster.



Dual vacuum circuit on request

All vacuum lifters with fixed vertical frame feature a single vacuum circuit. On request, a dual vacuum circuit is available.



Radio remote control or pushbutton cable control

Aspiration and release commands can be controlled at distance with wired or wireless controls. The radio remote control option must be indicated while ordering the vacuum lifter, as it is not available for purchase separately.



Two extra services

To support you on the job.
Because you're always on our mind.



RIGHETTI SERVICE: Don't stop your job. Simple, fast, concrete assistance.

We also give continual assistance even remotely: we help you over the phone and/or in video calls, so that your job doesn't ever shut down. We stand by your side with rapid and precise assistance, provided directly by those who designed and built your lifter.

We'll also skilfully guide you in your selection of the accessories most suited to your needs to allow you to always work safely and be able to get the top tools.

If what you urgently need is a spare part, we guarantee record response time.

We do all this for you:

- over the phone assistance
- videoconference assistance
- direct contact with the person that assembled your lifter
- remote assistance for ordinary and extraordinary maintenance
- spare parts service

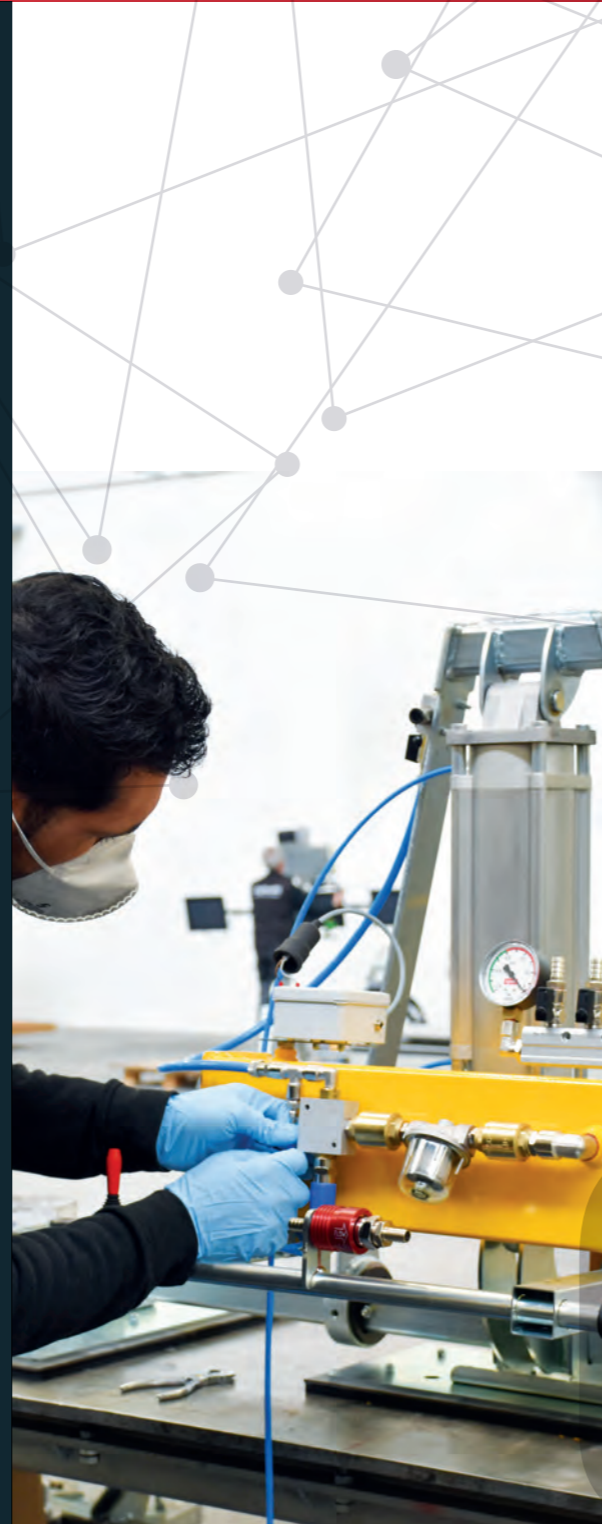

CUSTOMER CARE: what if you'll never be alone, wherever you are?

We know that during your job many questions can come up. Just like they can come up when choosing your lifter, or after having purchased it.

Your questions are important to us. Not only don't we want to miss them, but also we have created an ad hoc Customer Care. It will be available to answer any of your questions and needs, and you'll be able to get it anywhere: our website, social networks, by phone, or email. Wherever you are, we are there, too.





CLADDING



SHEET METAL



STONE



WOOD



GLASS



SPECIAL



CERAMIC

The only vacuum lifters
specialists for every application.
Especially yours.

Righetti
smart vacuum lifters



ITS

Righetti
smart vacuum lifters



SILCOM NORTH

www.silcomnorth.com hello@silcomnorth.com

Phone/Whatsapp +370 672216691 Goštauto 8, Vilnius 01108, Lithuania