

Righetti
smart vacuum lifters



Vacuum lifters
specifically for **marble,**
granite and stone

Vacuum
lifters
SPECIALISTS

Italian craftsmanship
and smart technology:
your vacuum lifter
for every application



Specialists in Vacuum Lifters

For over 20 years we've been working combining typical Italian handicraft creativity with the a technological and industrial advancement. The perfect mix of these two views has led to the conception and design of a broad range of products that we can introduce you to, both from the catalog and custom .

We like solutions that work, that get there by the requested deadlines, and that come with rapid, competent service catered to the customer.

We love getting anywhere with our lifters, even on a global scale. The experience we've gathered on the field helps us give you accurate answers, no matter where you are.

The geographic area isn't a limit anymore, but a way to make new long-lasting relationships. Because buying a Righetti means finding a reliable and efficient ally for optimizing your productivity.

From hands experienced in working the metal, from a precise and industrial organisation: this is where your vacuum lifter takes shape.



**Design and
production**



**More than
500 models**



**3500 m²
warehouse**



**International
shipments**

Why using vacuum lifters?

For some time now, vacuum lifters have been a very valuable aid in handling and lifting marble slabs, granite and other stones.



Why choosing a Righetti?

Cutting-edge technology, user-friendliness, ergonomics, safe use. **All in one machine.**

What are the pros?

Righetti has designed vacuum lifters capable of automating the work, thus reducing the time of production.

- Make work easier, safer and more rapid
- Reduce handling times and costs of the staff
- Immediate suction of the load
- Wide choice of models and possibilities of customization

How does it work?

- 1 Safety devices:** constant monitoring vacuum level, visual and acoustic warning systems
- 2 Power supply:** electric, battery or compressed air
- 3 Suction pads:** specific for marble, granite and stones
- 4 Vacuum circuit:** tested reliability and safety

Righetti Service: your assistance

We support you via phone and video to never leave your work unfinished. We are by your side with fast and precise assistance directly from those who built your vacuum lifter, for never stop your production.

Fast production

Artisan heart and industrial production: the perfect combination to give you your preferred vacuum lifter in the shortest time possible.

Safety above all else

Both the worker and the load are always taken as the focal points during the design and construction of the lifters. Reliability is guaranteed.

Worldwide shipment

Our vacuum lifters reach everywhere, even to you. Experience and relationships with customers throughout the world allow us to ship anywhere in established times.

Righetti
smart vacuum lifters

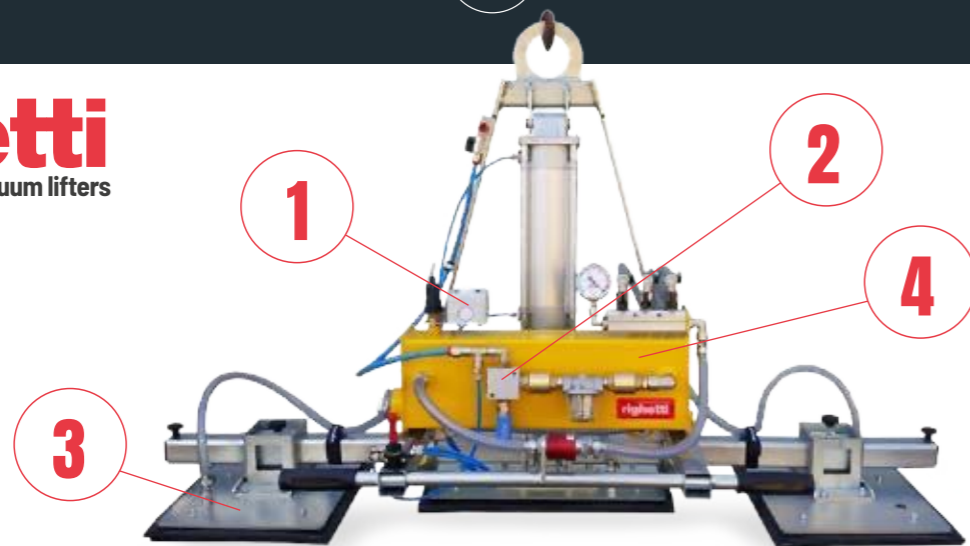

Specialists in vacuum lifters not just talk, but real advantages for your job



1 Absolute focus on safety

The load and operator are always protected with Righetti systems

Our vacuum lifters are equipped with a vacuum control system that ensures the safe handling of the load. The dual acoustic and visual alarm warns the operator if there isn't enough vacuum to lift the load safely. The ample vacuum reserve on the lifter guarantees a hold on the load even if there is a malfunction or the power gets cut off.

3 Lifters with sturdy structures for professional use

**Compact but robust structures
to last over time**

Righetti lifters have a structure that is sturdy, yet compact and streamlined at the same time. Solid frames made of zinc-coated high quality steel with thickness above standard: only the best to guarantee the stability of the load and the life of the vacuum lifter over time.

2 Suitable to any size load

**Modular configurations and customized
suction pads: every need is fulfilled**

The research and development division designed the lifters contemplating the most common needs of handling stones, marble and granite slabs. Our lifters have suction pads that can move across the arms, pads shut-off systems through practical valves, and the possibility of modify the direction of the suction pads to adapt the lifter.

4 Gripping speed and instant suction

**The lifters' gripping speed will get
the job done faster**

Vacuum lifters become handy when you need to get the job done faster. It will also help you in lowering labor costs.

The technology developed by Righetti make grabbing the load extremely faster. This is because our R&D has designed specific suction pads to guarantee an optimal hold and a fast adhesion to the load.

5 Suitable for stones with irregular surfaces

**Bush-hammered or flamed slabs will
not be a problem anymore**

Righetti vacuum lifters feature gaskets specifically designed to adapt even to load which are not perfectly smooth, being able to stick on bush-hammered, flamed and rough cut slabs. For the most irregular stones' surfaces, we have specific solutions.

7 Ease of maintenance

**Cleanliness and maintenance
are much faster**

Our vacuum lifters are based on the simplicity of cleaning of the vacuum system, thanks to the wide and comfortable cap placed on the lifter's tank. This feature makes easier to clean the lifter a protect the correct functioning of it.

6 Ideal for every need, even yours

**No matter the manufacturing process,
we have the right solution**

Models with electric operating system, pneumatic or autonomous battery powered. Solutions with several configurations, either for horizontal lifting or with manual or powered tilting system. A complete series of vacuum lifters suitable for every kind of slab, marble's semi-finished, granite and other stones.

MEMBER OF



Technical Features

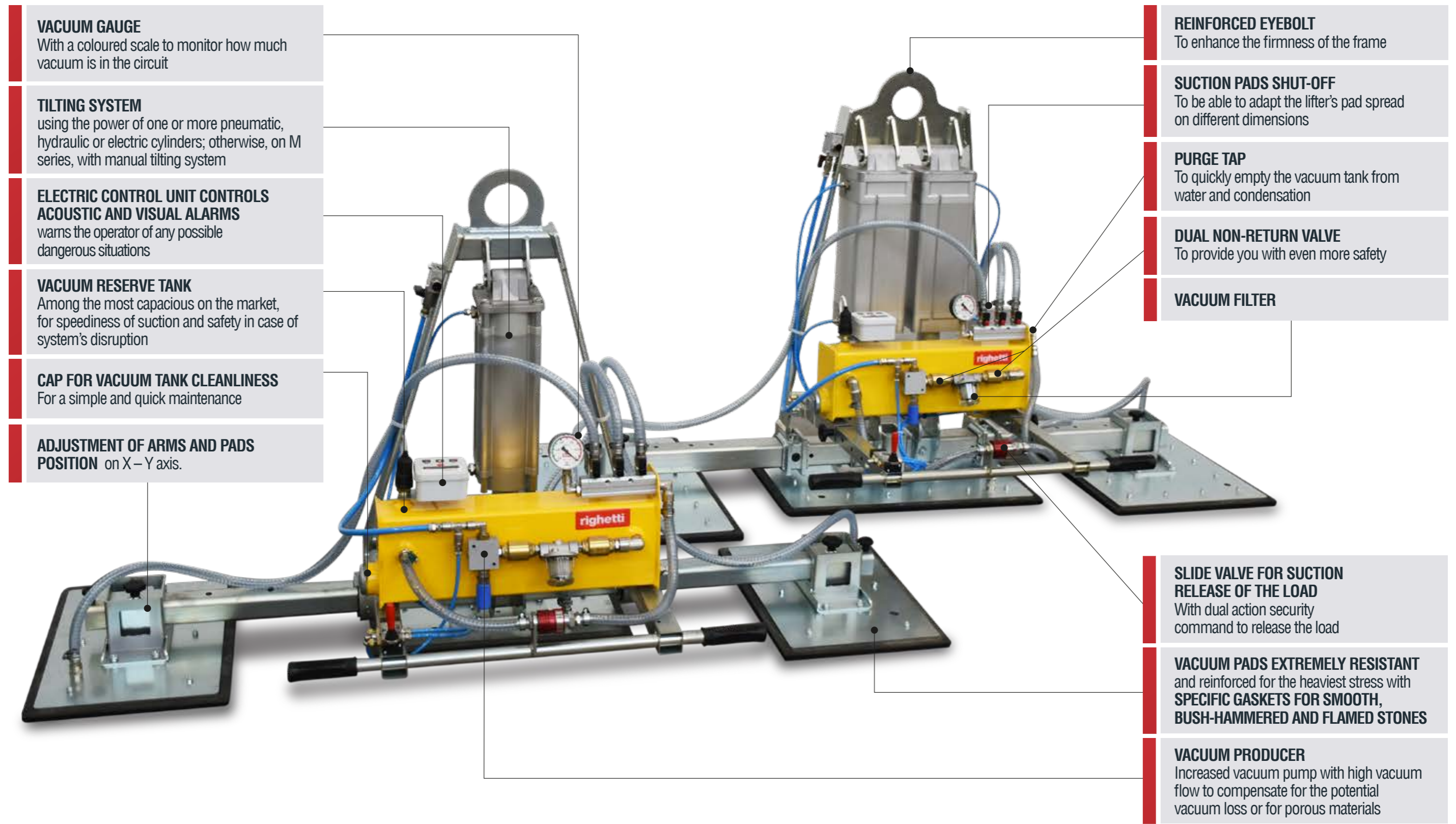

VACUUM GAUGE

With a coloured scale to monitor how much vacuum is in the circuit

TILTING SYSTEM

using the power of one or more pneumatic, hydraulic or electric cylinders; otherwise, on M series, with manual tilting system

ELECTRIC CONTROL UNIT CONTROLS ACOUSTIC AND VISUAL ALARMS

warns the operator of any possible dangerous situations

VACUUM RESERVE TANK

Among the most capacious on the market, for speediness of suction and safety in case of system's disruption

CAP FOR VACUUM TANK CLEANLINESS

For a simple and quick maintenance

ADJUSTMENT OF ARMS AND PADS POSITION on X – Y axis.

REINFORCED EYEBOLT

To enhance the firmness of the frame

SUCTION PADS SHUT-OFF

To be able to adapt the lifter's pad spread on different dimensions

PURGE TAP

To quickly empty the vacuum tank from water and condensation

DUAL NON-RETURN VALVE

To provide you with even more safety

VACUUM FILTER

SLIDE VALVE FOR SUCTION RELEASE OF THE LOAD

With dual action security command to release the load

VACUUM PADS EXTREMELY RESISTANT and reinforced for the heaviest stress with **SPECIFIC GASKETS FOR SMOOTH, BUSH-HAMMERED AND FLAMED STONES**

VACUUM PRODUCER

Increased vacuum pump with high vacuum flow to compensate for the potential vacuum loss or for porous materials

Table of Contents

12

Compressed air operated

PICCOLA	15
M1A	16
P1A	17
M2A	18
P2A	19
M3A	20
P3A	21
M4A-L	22
P4A-L	23
M4A	24
P4A	25

Lowered frame

S2-M/SF2-M	28
S2-PN/SF2-PN	29
S3-M/SF3-M	30
S3-PN/SF3-PN	31
S4-PN	32

34

Specific for countertops

M3K	36
P3-K / O3-K	37
M4K	38
P4-K / O4-K	39
M5-K	40
P4-K / O4-K	41
P5A625KX	42
SF4K-PN	43
P4AK-RCM	44
Optional for countertops	45

46

For ceramic slabs and fragile materials

P8 – E8	48
P12 – E12	49
P24A	50

52

Electrically operated

M1EB / O1EB	54
M2EB / O2EB	55
M3EB / O3EB	56
M4EB / O4EB	57

58

Battery operated

M1B / O1B	60
M2B / O2B	61
M3B / O3B	62
M4B / O4B	63

64

Specific for outdoor use

S1-MP	66
S1-B	67
Optional for S1 series	68
EDIL	70

72

Separate vacuum pump

74

Custom solutions

75

Optional

Righetti offers a wide range of vacuum lifters for lifting marble, granite and other types of stone

The compressed air powered vacuum lifters are the solution to be used with a jib crane or other lifting means where the pneumatic connection is available.

On compressed air operated vacuum lifters, the vacuum pump Venturi is built on the lifter's frame: in this way it only needs the connection to the compressor.

In addition to standard models, we can produce customized vacuum lifter based on customer's needs.

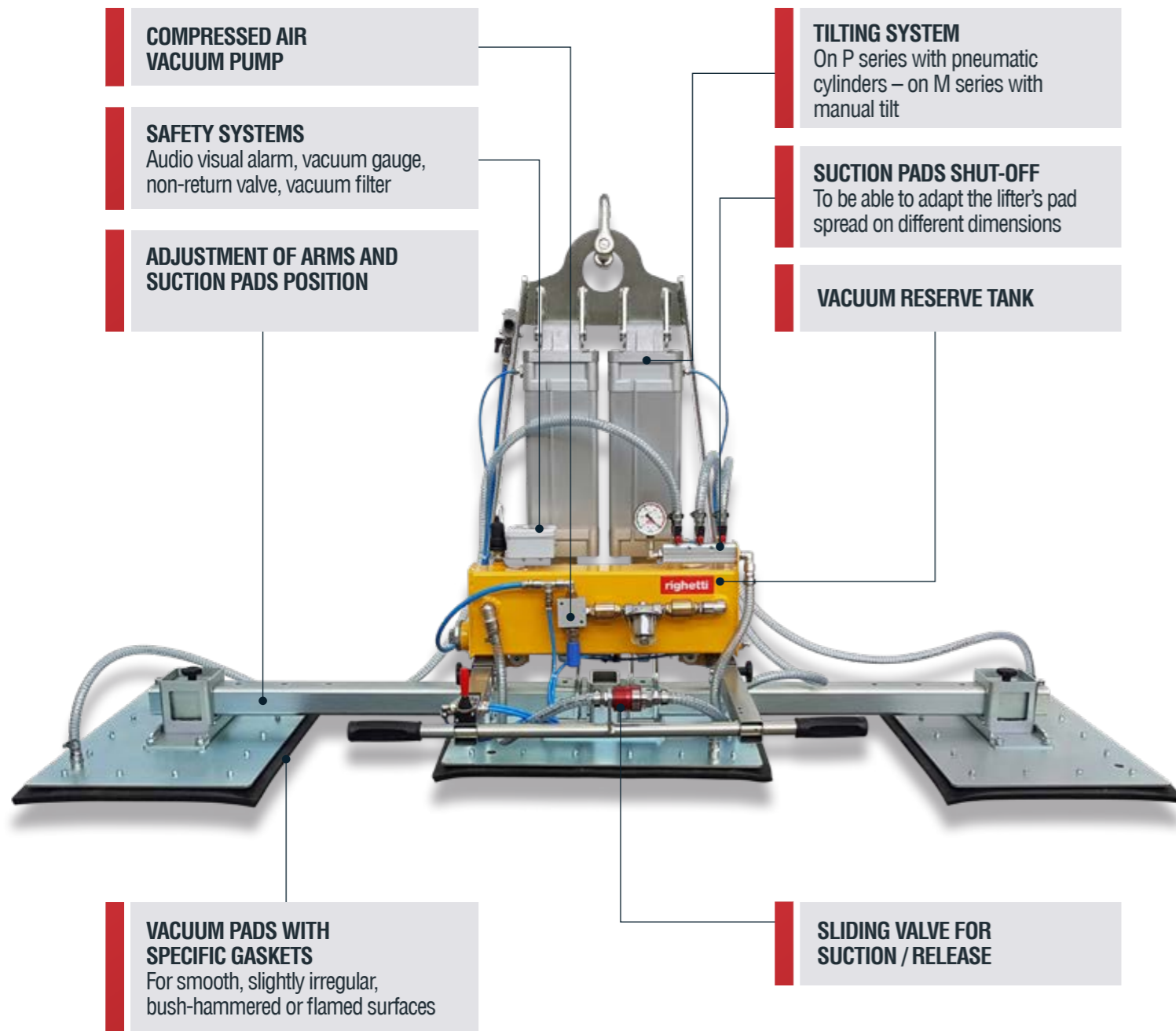

Stone vacuum lifters compressed air operated



Compressed air (operating)



Pneumatic tilt 0-90°



Manual tilt 0-90°



PICCOLA

Power supply
AIR aria compressa

Pads no.
1



PICCOLA is a compact vacuum lifter that is ideal for handling and lifting stones with limited dimensions and weight. Thanks to its 11kg of weight, it is a comfortable, lightweight and versatile vacuum lifter.

This model is operated by compressed air and it is available with three different lifting capacities (100kg - 125kg - 250kg)



PICCOLA series

 **100 - 250 kg**

Lifting capacity Kg	Suction pads nr	Suction pad size (AxB) mm	Below-the-hook height (H) mm	Lifter weight Kg	Product code
100	1	580 x 180	395	11	PICCOLA100
125	1	480 x 230	395	11	PICCOLA125
250	1	480 x 330	395	11	PICCOLA200

Technical drawings

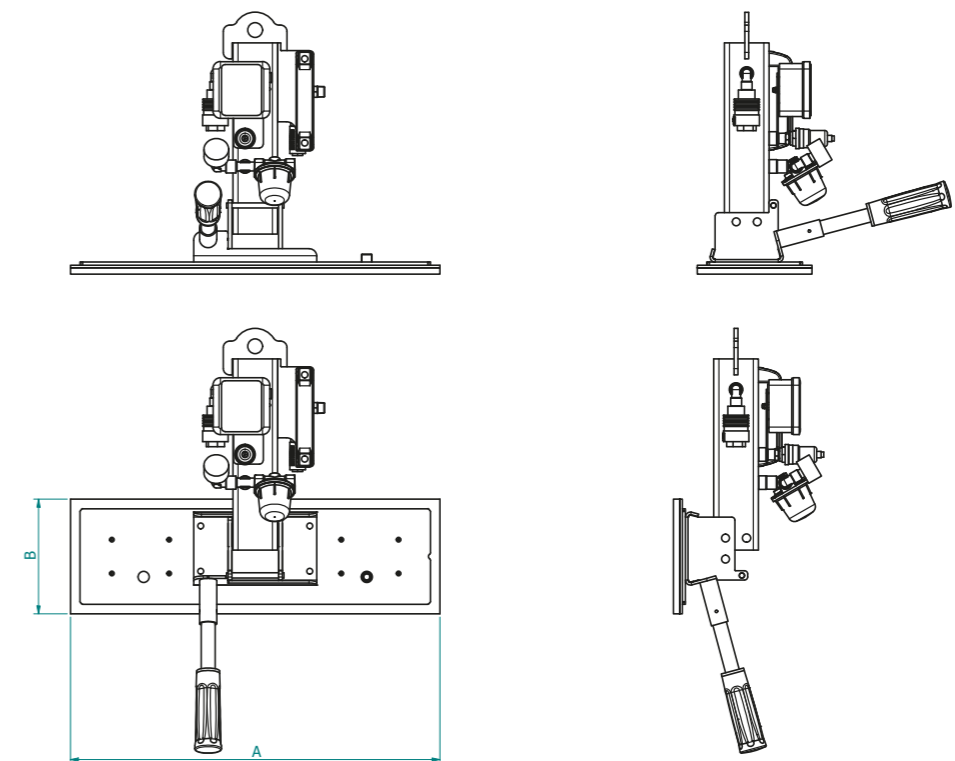

M1A

Power supply
AIR Compressed-air

Pads no.
1



M1A models are a series of small and compact vacuum lifters with one suction pad, with lifting capacity up to 1000kg.

The manual tilting system allows the movement of the load from vertical to horizontal and vice-versa.

M1A series

100 - 1000 Kg

Capacity Kg	Pads no.	Suction pads size (AxB) mm	Below-the-hook height (H) mm	Tare Kg	Model
100	1	380 x 230	380	20	M1A 100
		580 x 180			
125	1	480 x 230	380	21	M1A 125
200	1	730 x 190	380	22	M1A 200
250	1	630 x 280	380	24	M1A 250
300	1	630 x 330	380	28	M1A 300
500	1	630 x 430	380	36	M1A 500
750	1	830 x 480	450	60	M1A 750
1000	1	960 x 530	450	63	M1A 1000

Technical drawings

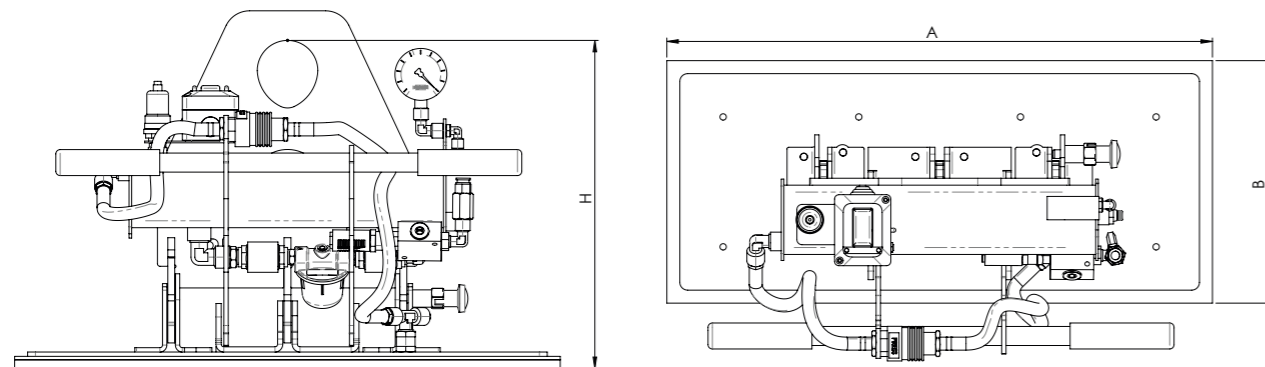

P1A

Power supply
AIR Compressed-air

Pads no.
1

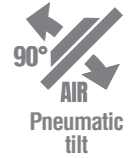

P1A models are a series of vacuum lifter with one suction pad, with lifting capacity up to 1000kg, especially indicated to handle slabs of compact dimensions.

The tilting system is powered by a pneumatic cylinder and is controlled via a joystick placed on the lifter's handle.

P1A series

125 - 1000 Kg

Capacity Kg	Pads no.	Suction pads size (AxB) mm	Cylinder no.	Below-the-hook height (H) mm	Tare Kg	Model
125	1	480 x 230	1	870	42	P1A 125
200	1	730 x 190	1	870	47	P1A 200
250	1	630 x 280	1	870	47	P1A 250
300	1	630 x 330	1	870	50	P1A 300
500	1	630 x 430	1	870	55	P1A 500
750	1	830 x 480	1	955	66	P1A 750
1000	1	960 x 530	2	870	88	P1A 1000

Technical drawings

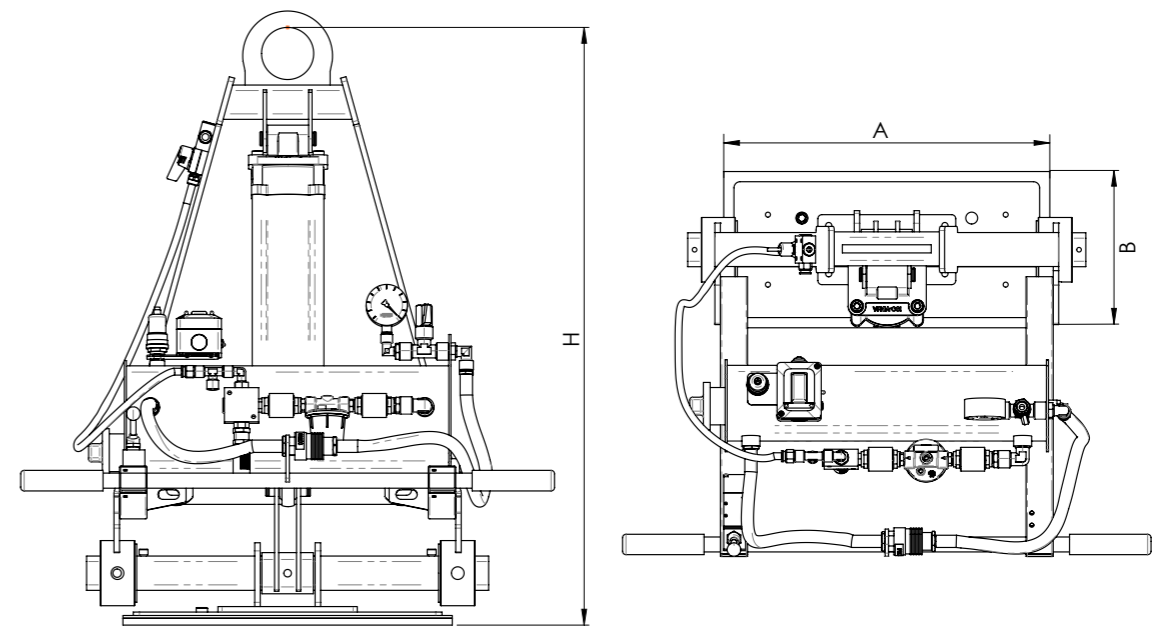

M2A

Power supply
AIR Compressed-air

Pads no.
2



M2A is a vacuum stone lifter with two suction pads and lifting capacity up to 1500kg. The length of the central beam is 1500 mm. This lifter allows to calibrate the position of the pads along the central beam, and to switch the direction of the pads.

The manual tilting system assures the movement of the load from vertical to horizontal and vice-versa.



M2A series

250 - 1500 Kg

Capacity Kg	Pads no.	Suction pads size (AxB) mm	Beam (L) mm	Below-the-hook height (H) mm	Tare Kg	Model
250	2	480 x 230	1500	450	55	M2A 250
500	2	480 x 330	1500	450	62	M2A 500
1000	2	630 x 430	1500	450	86	M2A 1000
1500	2	830 x 480	1500	450	88	M2A 1500

Technical drawings

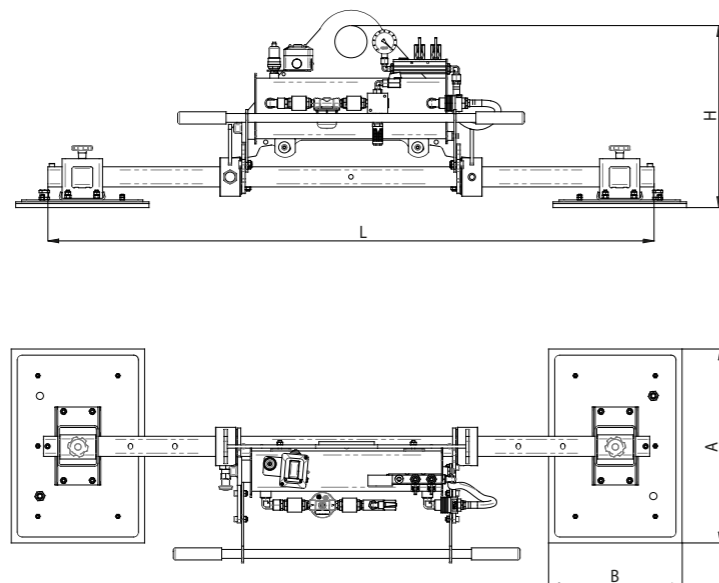

P2A

Power supply
AIR Compressed-air

Pads no.
2

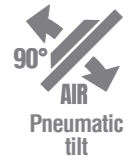

The models P2A are a series of vacuum stone lifters with lifting capacity up to 1500kg and pneumatic tilt. The length of the central beam is 1500mm.

This lifter allows to calibrate the position of the pads along the central beam, and to switch the direction of the pads.



P2A series

250 - 1500 Kg

Capacity Kg	Pads no.	Suction pads size (AxB) mm	Cylinder no.	Beam (L) mm	Below-the-hook height (H) mm	Tare Kg	Model
250	2	480 x 230	1	1500	870	60	P2A 250
500	2	480 x 330	1	1500	870	68	P2A 500
1000	2	630 x 430	2	1500	870	94	P2A 1000
1500	2	830 x 480	2	1500	955	120	P2A 1500

Technical drawings

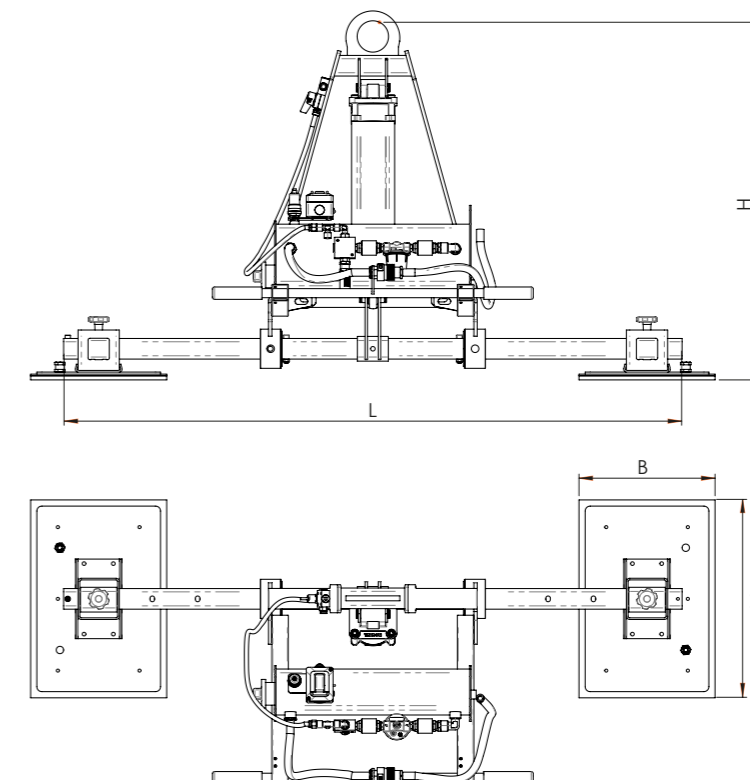

M3A

Power supply
AIR Compressed-air

Pads no.
3



M3A models are a series of vacuum stone lifters with 3 suction pads and lifting capacity up to 2000kg. The length of the central beam is 1500mm. In addition to the relocation of the pads along the cross beam and their rotation, this model can be used also with the central pad only, to handle and lift smaller loads.

The manual tilting system allows the movement of the load from vertical to horizontal and vice-versa.



M3A series

375 - 2000 Kg

Capacity Kg	Pads no.	Suction pads size (AxB) mm		Beam (L) mm	Below-the-hook height (H) mm	Tare Kg	Model
		Central suction pad (A1xB1)	Lateral suction pads (AxB)				
375	3	480 x 230	480 x 230	1500	450	61	M3A 375
625	3	480 x 230	480 x 330	1500	450	67	M3A 625
750	3	480 x 330	480 x 330	1500	450	80	M3A 750
1000	3	630 x 330	630 x 330	1500	450	86	M3A 1000
1200	3	630 x 280	630 x 430	1500	450	105	M3A 1200
1500	3	630 x 430	630 x 430	1500	450	120	M3A 1500
2000	3	830 x 480	830 x 480	1500	450	147	M3A 2000

Technical drawings

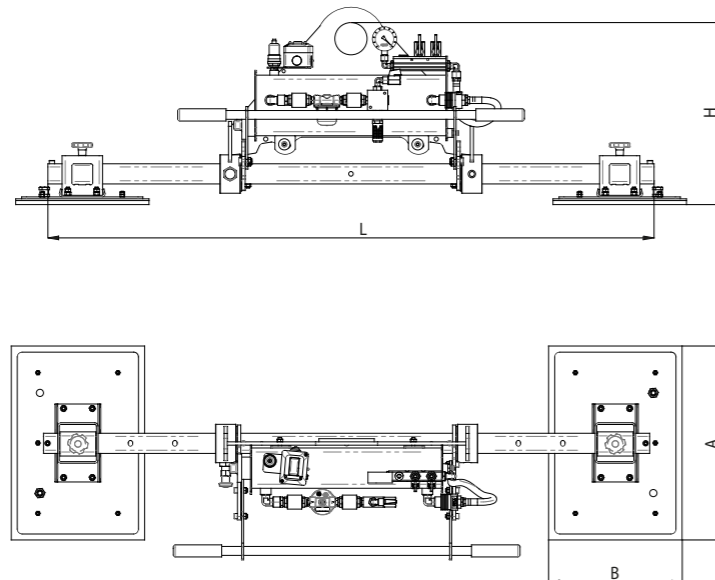

P3A

Power supply
AIR Compressed-air

Pads no.
3

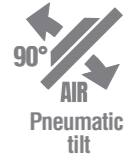

P3A models are a series of vacuum stone lifters with 3 suction pads and lifting capacity up to 2000kg. The length of the central beam is 1500mm. In addition to the relocation of the pads along the cross beam and their rotation, this model can be used also with the central pad only, to handle and lift loads of smaller dimensions.

The tilting system is powered by one or more pneumatic cylinders which allow the movement of the load from vertical to horizontal and vice-versa.



P3A series

375 - 2000 Kg

Capacity Kg	Pads no.	Suction pads size (AxB) mm		Cylinder no.	Beam (L) mm	Below-the-hook height (H) mm	Tare Kg	Model
		Central suction pad (A1xB1)	Lateral suction pads (AxB)					
375	3	480 x 230	480 x 230	1	1500	870	70	P3A 375
625	3	480 x 230	480 x 330	1	1500	870	72	P3A 625
750	3	480 x 330	480 x 330	1	1500	955	85	P3A 750
1000	3	630 x 330	630 x 330	2	1500	870	102	P3A 1000
1200	3	630 x 280	630 x 430	2	1500	870	130	P3A 1200
1500	3	630 x 430	630 x 430	2	1500	955	145	P3A 1500
2000	3	830 x 480	830 x 480	3	1500	955	200	P3A 2000

Technical drawings

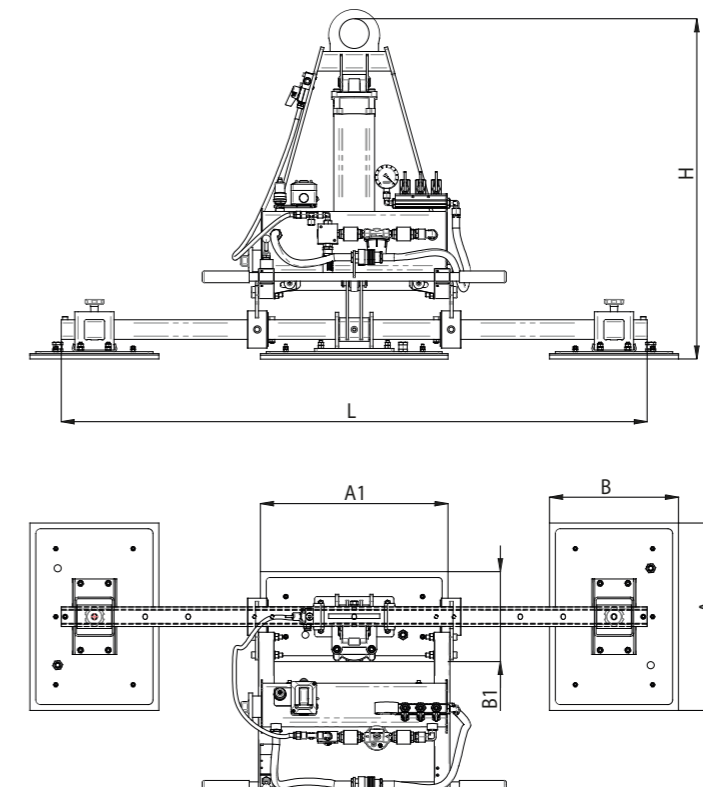

M4A-L

Power supply
AIR Compressed-air

Pads no.
4



M4A-L is a series of vacuum stone lifters with 4 suction pads in a row and lifting capacity up to 2000kg. These vacuum lifters are specially suitable to guarantee the right support during the movement of big slabs.

The manual tilting system allows the movement of the load from vertical to horizontal and vice-versa.

M4A-L series

500 - 2000 Kg

Capacity Kg	Pads no.	Suction pads size (AxB) mm	Beam (L) mm	Below-the-hook height (H) mm	Tare Kg	Model
500	4	480 x 230	1500	450	74	M4A 500L
1000	4	480 x 330	1500	450	100	M4A 1000L
1500	4	630 x 330	1500	450	112	M4A 1500L
2000	4	630 x 430	2200	450	130	M4A 2000L

Technical drawings

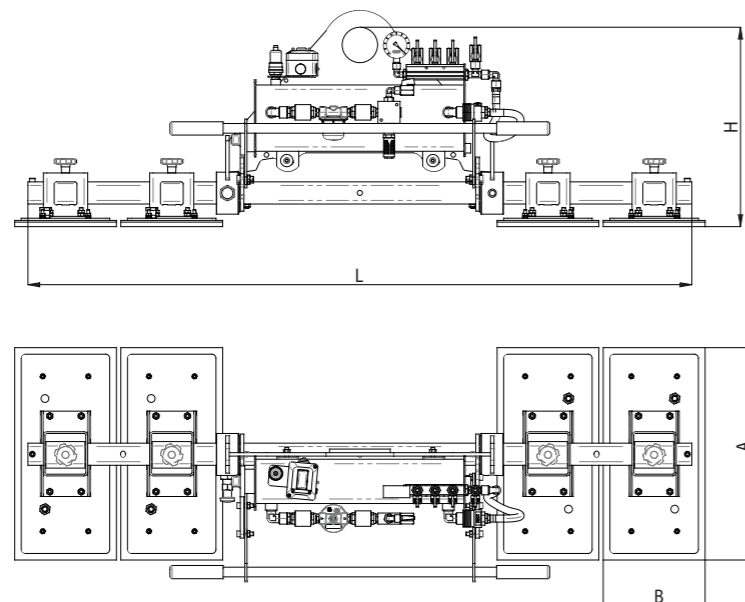

P4A-L

Power supply
AIR Compressed-air

Pads no.
4

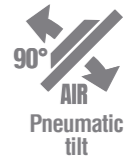

P4A-L is a series of vacuum stone lifters with 4 suction pads in a row and lifting capacity up to 2000kg. These vacuum lifters are specially suitable to guarantee the right support during the movement of big slabs.

The tilting system is powered by one or more pneumatic cylinders which allow the movement of the load from vertical to horizontal and vice-versa.

P4A-L series

500 - 2000 Kg

Capacity Kg	Pads no.	Suction pads size (AxB) mm	Cylinder no.	Beam (L) mm	Below-the-hook height (H) mm	Tare Kg	Model
500	4	480 x 230	1	1500	870	85	P4A 500L
1000	4	480 x 330	2	1500	870	109	P4A 1000L
1500	4	630 x 330	2	1500	955	130	P4A 1500L
2000	4	630 x 430	3	2200	955	228	P4A 2000L

Technical drawings

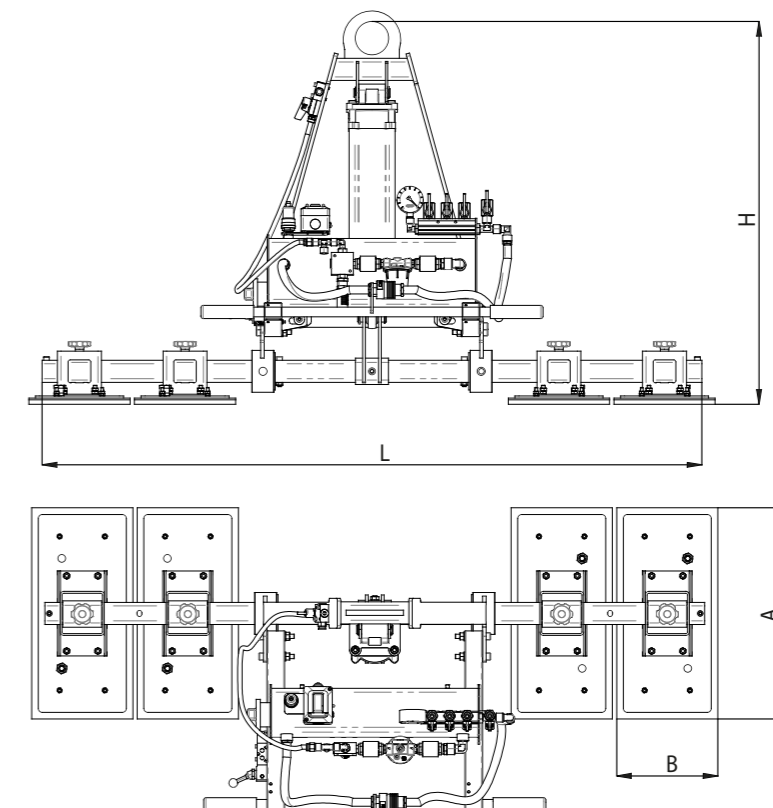

M4A

Power supply
AIR Compressed-air

Pads no.
4



M4A models are a series of vacuum stone lifters with 3 suction pads and lifting capacity up to 2000kg. The length of the central beam is 1500mm. This lifter allows to calibrate the position of the pads along the central beam, and to switch the direction of the pads.

These model are particularly indicated for thin and fragile slabs.



M4A series

500 - 2000 Kg

Capacity Kg	Pads no.	Suction pads size (AxB) mm	Beam (L) mm	Below-the-hook height (H) mm	Tare Kg	Model
500	4	480 x 330	1500	450	92	M4A 500
1000	4	480 x 330	1500	450	109	M4A 1000
1500	4	630 x 330	1500	450	140	M4A 1500
2000	4	630 x 430	1500	450	160	M4A 2000

Technical drawings

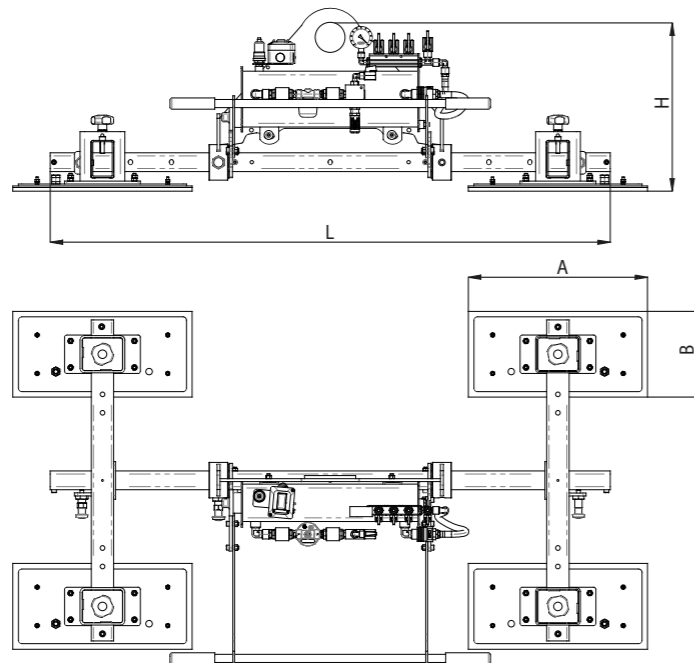

P4A

Power supply
AIR Compressed-air

Pads no.
4

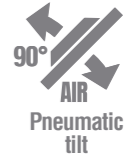

P4A is a series of vacuum stone lifters with 4 crossed suction pads and lifting capacity up to 2000kg. The length of the central beam is 1500mm. This lifter allows to calibrate the position of the pads along the central beam, and to switch the direction of the pads.

The tilting system is powered by one or more pneumatic cylinders which assure the movement of the load from vertical to horizontal and vice-versa.



P4A series

500 - 2000 Kg

Capacity Kg	Pads no.	Suction pads size (AxB) mm	Cylinder no.	Beam (L) mm	Below-the-hook height (H) mm	Tare Kg	Model
500	4	480 x 230	1	1500	870	102	P4A 500
1000	4	480 x 330	2	1500	870	147	P4A 1000
1500	4	630 x 330	2	1500	955	150	P4A 1500
2000	4	630 x 430	3	1500	955	223	P4A 2000

Technical drawings

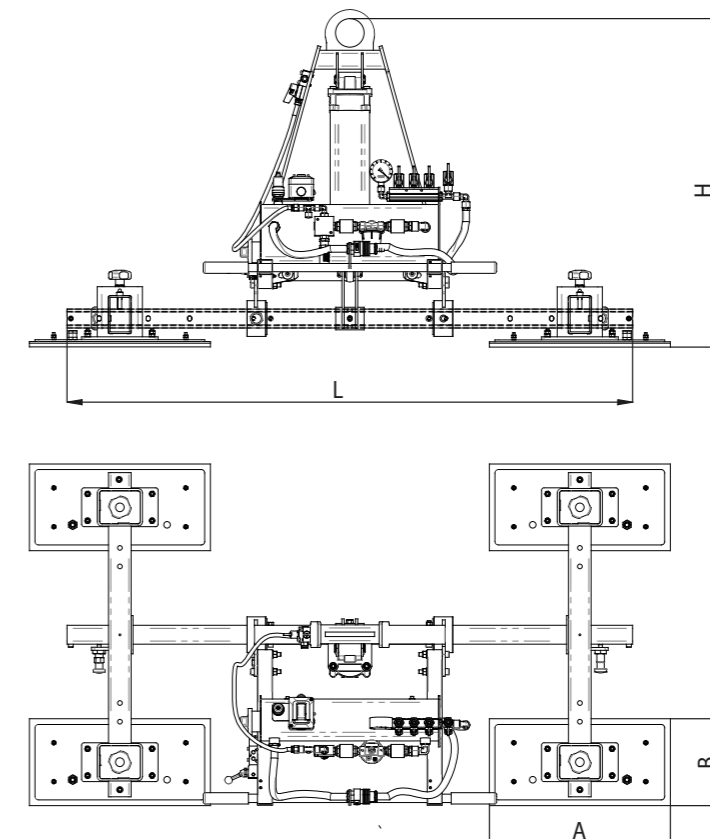

Vacuum lifters with lowered-height structure

In addition to the series of vacuum lifters with compressed air operating system, Righetti also offers pneumatic models with lowered structure.

These models represent a valuable solution in those situations where the ceiling is low or there is a limited below-the-hook height.

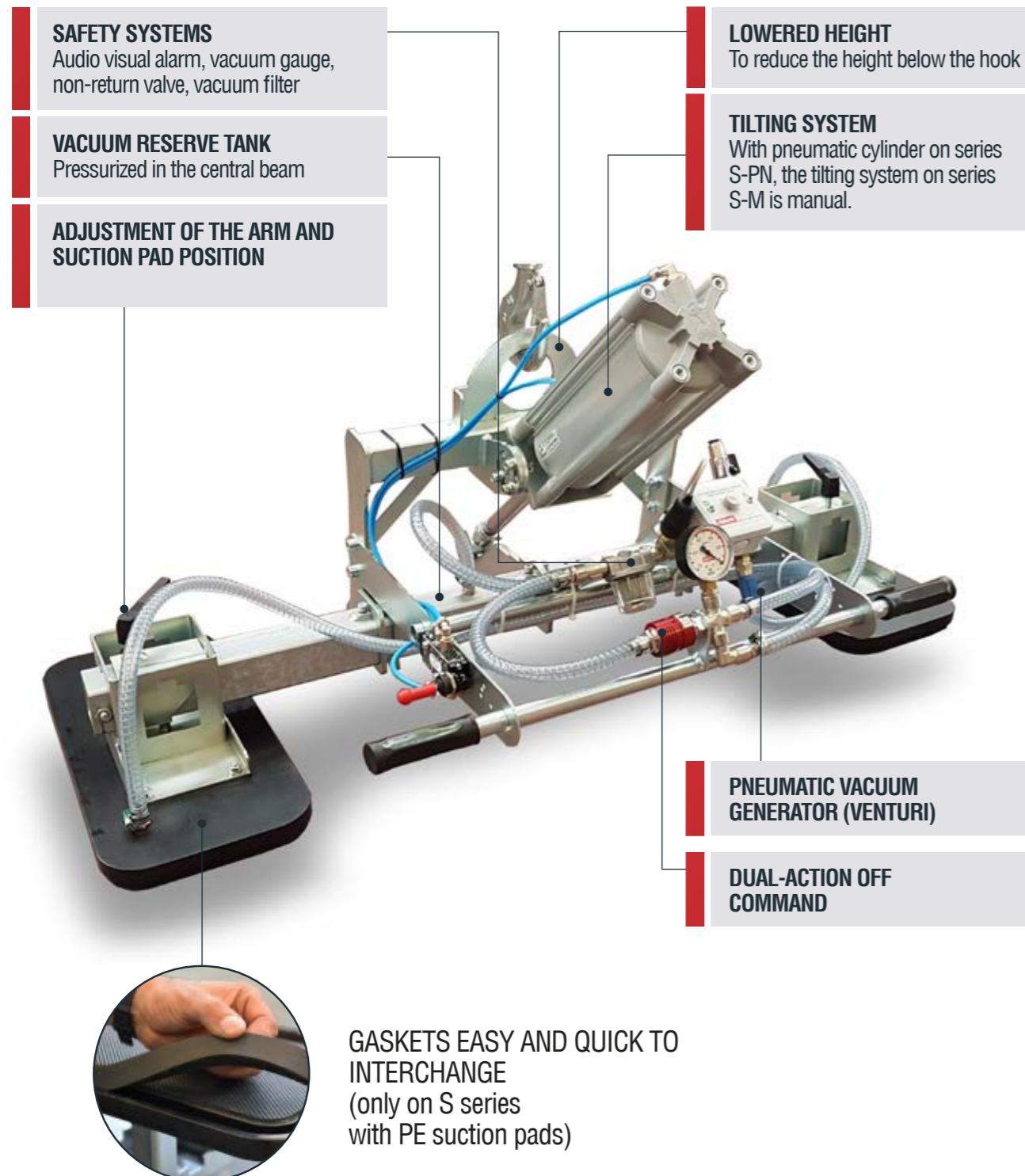

Stone vacuum lifters compressed air operated with lowered frame



Compressed air (operating)



Pneumatic tilt 0-90°



Manual tilt 0-90°

Righetti
smart vacuum lifters

S2-M / SF2-M

Power supply
AIR Compressed-air

Pads no.
2



S2-M and SF2-M models are a series of vacuum stone lifters with lifting capacity up to 500kg. They have a compact structure and two suction pads which can be repositioned along the central beam. This one is available with length 1200mm or 2400mm.

The manual tilting system allows the movement of the load from vertical to horizontal and vice-versa.

S2-M vacuum lifter is equipped with PE suction pads with easily interchangeable gaskets, while SF2-M mounts standard metal suction pads.

S2-M / SF2-M series

250 - 500 Kg

Capacity Kg	Pads no.	Suction pads size (AxB) mm	Beam (L) mm	Below-the-hook height (H) mm	Tare Kg	Model with PE suction pads	Model with metal suction pads
250	2	480 x 230	1200	440	32	S2-M-250	SF2-M-250
			2400		42	S2-M-250/2400	SF2-M-250/2400
500	2	480 x 330	1200	440	37	S2-M-500	SF2-M-500
			2400		47	S2-M-500/2400	SF2-M-500/2400

Technical drawings

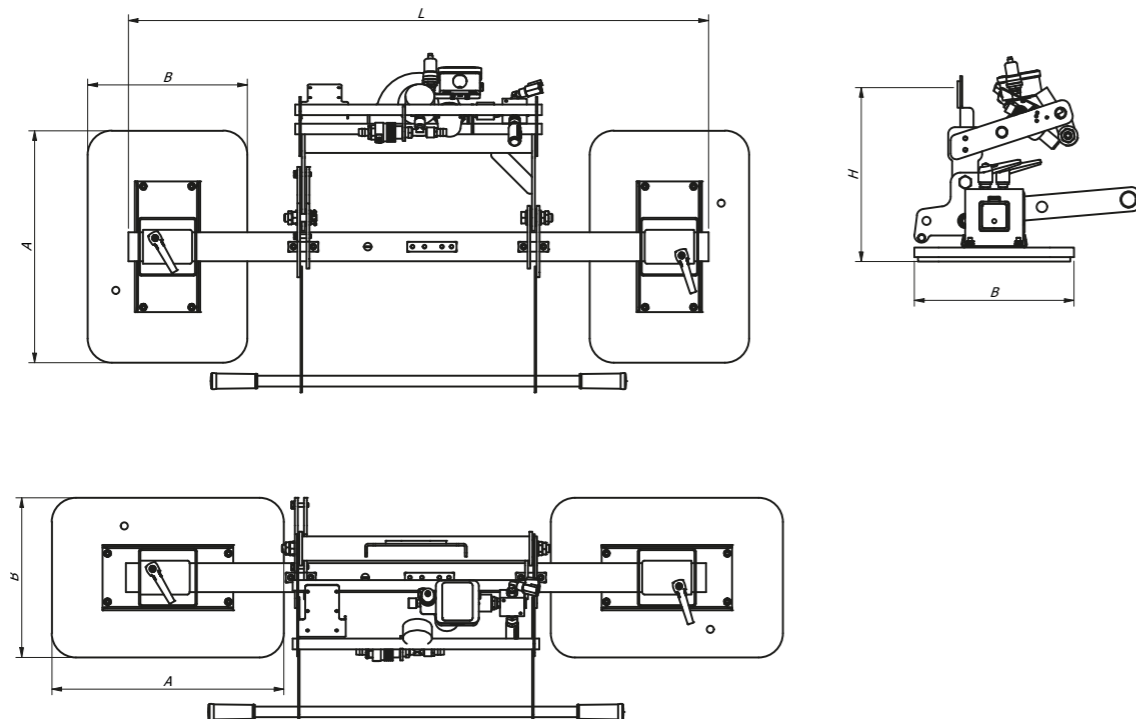

S2-PN / SF2-PN

Power supply
AIR Compressed-air

Pads no.
2

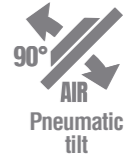

S2-PN and SF2-PN are a series of vacuum stone lifters with lifting capacity up to 500kg. The tilting system is powered by a pneumatic cylinder which allows the movement of the load from vertical to horizontal and vice-versa. The sloped position of the cylinder considerably reduces the height below the hook. In this model the suction pads can be moved along the central beam (available in version 1200mm or 2400mm).

While S2-PN mounts suction pads with easily interchangeable gaskets, SF2-PN has standard metal suction pads.

S2-PN / SF2-PN series

250 - 500 Kg

Capacity Kg	Pads no.	Suction pads size (AxB) mm	Cylinder no.	Beam (L) mm	Below-the-hook height (H) mm	Tare Kg	Model with PE suction pads	Model with metal suction pads
250	2	480 x 230	1	1200	440	38	S2-PN-250	SF2-PN-250
				2400		48	S2-PN-250/2400	SF2-PN-250/2400
500	2	480 x 330	1	1200	440	43	S2-PN-500	SF2-PN-500
				2400		53	S2-PN-500/2400	SF2-PN-500/2400

Technical drawings

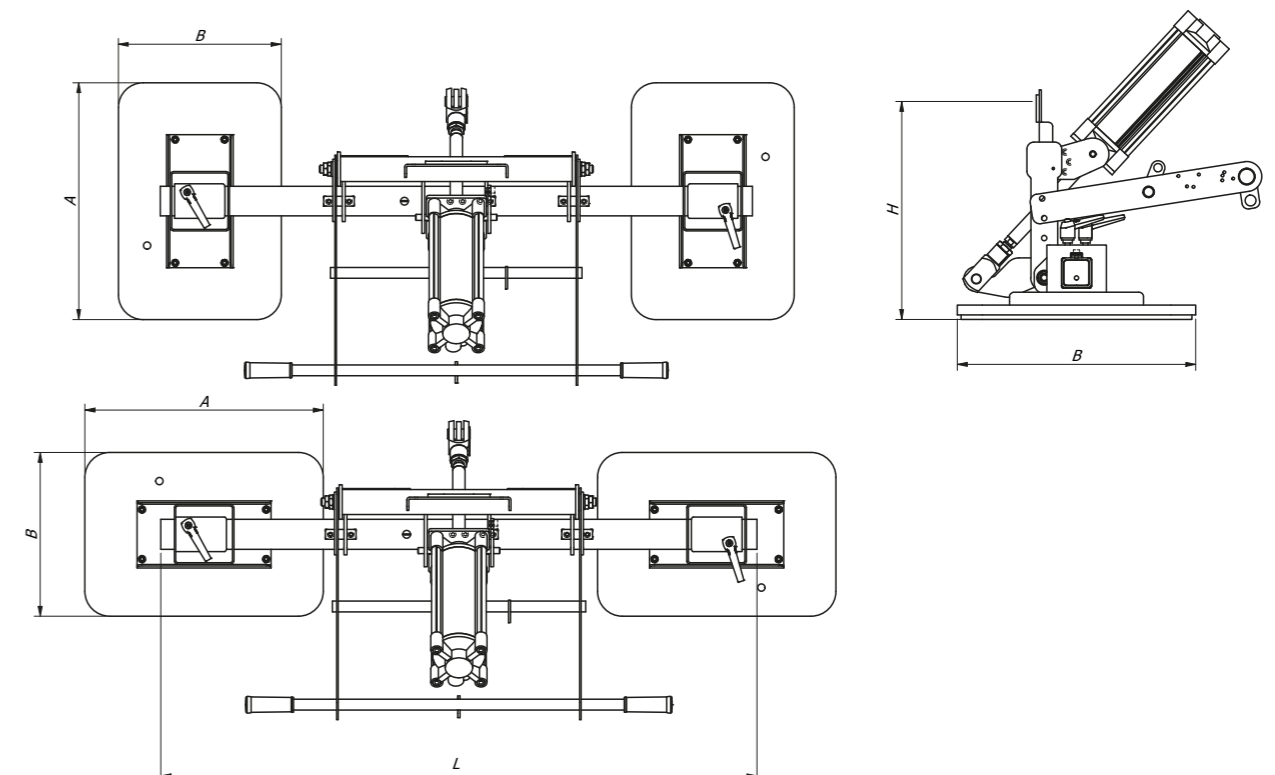

S3-M / SF3-M

Power supply
AIR Compressed-air

Pads no.
3



Lowered-structure models with three suction pads are a series of vacuum stone lifters with lifting capacity up to 750kg. They have a compact structure and three suction pads which can be repositioned along the central beam. The latter is available with length 1200mm or 2400mm. The manual tilting system allows the movement of the load from vertical to horizontal and vice-versa.

S3-M vacuum lifter is equipped with PE suction pads with easily interchangeable gaskets, while SF3-M mounts standard metal suction pads.

S3-M / SF3-M series

375 - 750 Kg

Capacity Kg	Pads no.	Suction pads size (AxB) mm		Beam (L) mm	Below-the-hook height (H) mm	Tare Kg	Model with PE suction pads	Model with metal suction pads
		Central suction pad (A1xB1)	Lateral suction pads (AxB)					
375	3	480 x 230	480 x 230	1200	440	37	S3-M-375	SF3-M-375
				2400		47	S3-M-375/2400	SF3-M-375/2400
625	3	480 x 230	480 x 330	1200	440	38	S3-M-625	SF3-M-625
				2400		48	S3-M-625/2400	SF2-M-625/2400
750	3	480 x 330	480 x 330	1200	440	40	S3-M-750	SF3-M-750
				2400		50	S3-M-750/2400	SF2-M-750/2400

Technical drawings

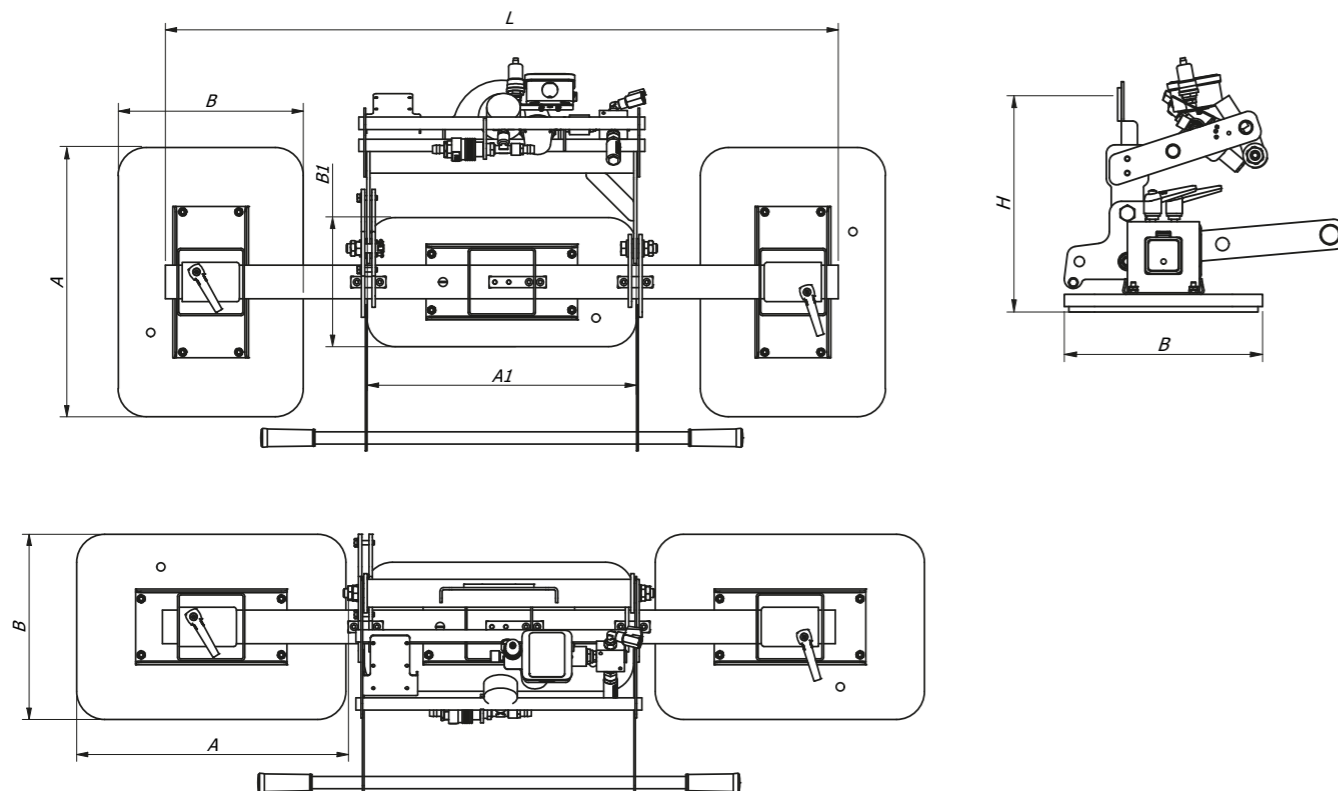

S3-PN / SF3-PN

Power supply
AIR Compressed-air

Pads no.
3

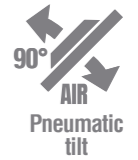

S3-PN and SF3-PN models are a series of vacuum stone lifters with lifting capacity up to 750kg. The tilting system is powered by a pneumatic cylinder which allows the movement of the load from vertical to horizontal and vice-versa.

The sloped position of the cylinder considerably reduces the height below the hook.

While S3-PN mounts suction pads with easily interchangeable gaskets, SF3-PN has standard metal frame suction pads.

S3-PN / SF3-PN series

375 - 750 Kg

Capacity Kg	Pads no.	Suction pads size (AxB) mm		Cylinder no.	Beam (L) mm	Below-the-hook height (H) mm	Tare Kg	Model with PE suction pads	Model with metal suction pads
		Central suction pad (A1xB1)	Lateral suction pads (AxB)						
375	3	480 x 230	480 x 230	1	1200	440	45	S3-PN-375	SF3-PN-375
				1	2400		55	S3-PN-375/2400	SF3-PN-375/2400
625	3	480 x 230	480 x 330	1	1200	440	46	S3-PN-625	SF3-PN-625
				2	2400		56	S3-PN-625/2400	SF2-PN-625/2400
750	3	480 x 330	480 x 330	2	1200	440	48	S3-PN-750	SF3-PN-750
				2	2400		58	S3-PN-750/2400	SF2-PN-750/2400

Technical drawings

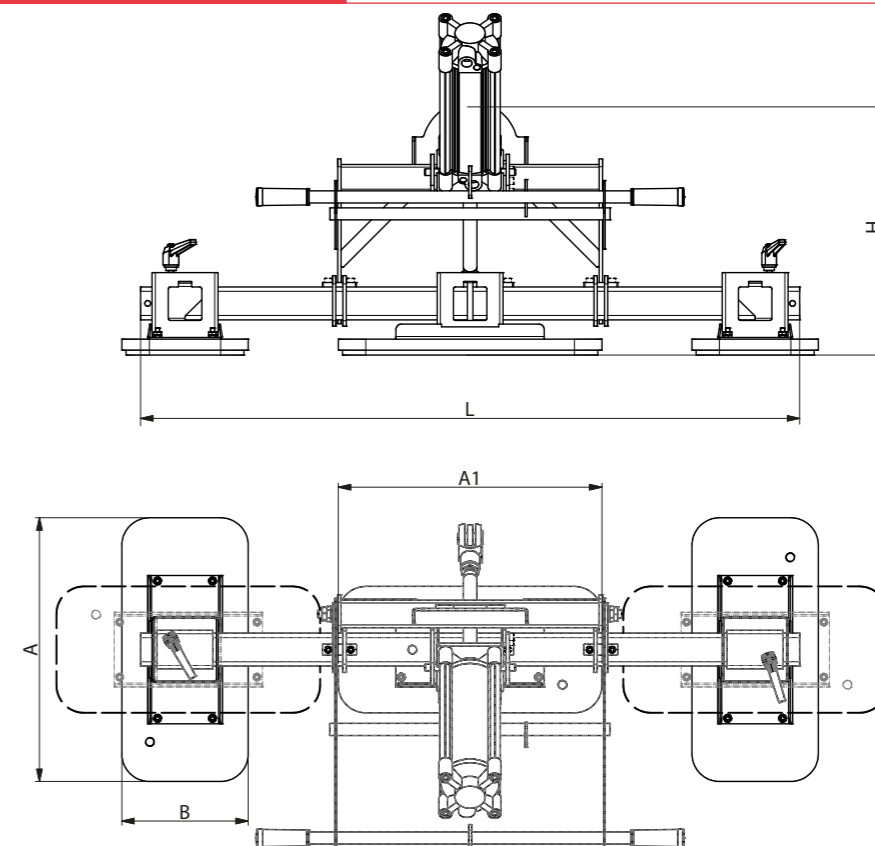

S4-PN / SF4-PN

Power supply
AIR Compressed-air

Pads no.
4

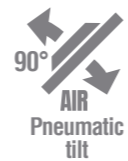

S4-PN and SF4-PN are a series of vacuum stone lifters with lifting capacity up to 500kg. The tilting system is powered by a pneumatic cylinder which allows the movement of the load from vertical to horizontal and vice-versa. The sloped position of the cylinder considerably reduces the height below the hook.

While S4-PN mounts suction pads with easily interchangeable gaskets, SF4-PN is equipped with standard metal frame suction pads.



S4-PN / SF4-PN series

 **500 Kg**

Capacity Kg	Pads no.	Suction pads size (AxB) mm	Beam (L) mm	Below-the-hook height (H) mm	Tare Kg	Model with PE suction pads	Model with metal suction pads
500	4	480 x 230	1200	440	76	S4-PN-500	SF4-PN-500
			2400		86	S4-PN-500/2400	SF4-PN-500/2400

Technical drawings

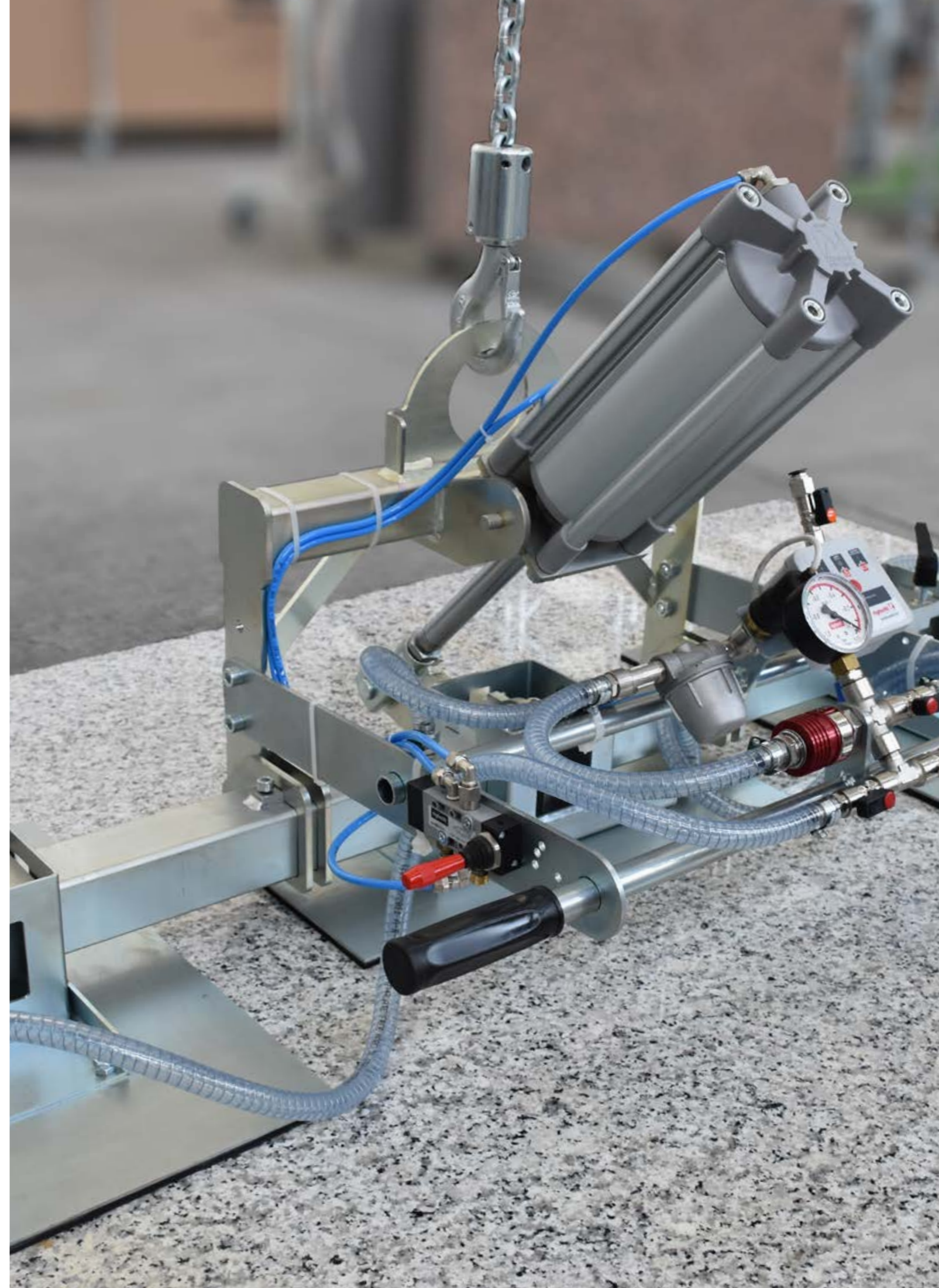
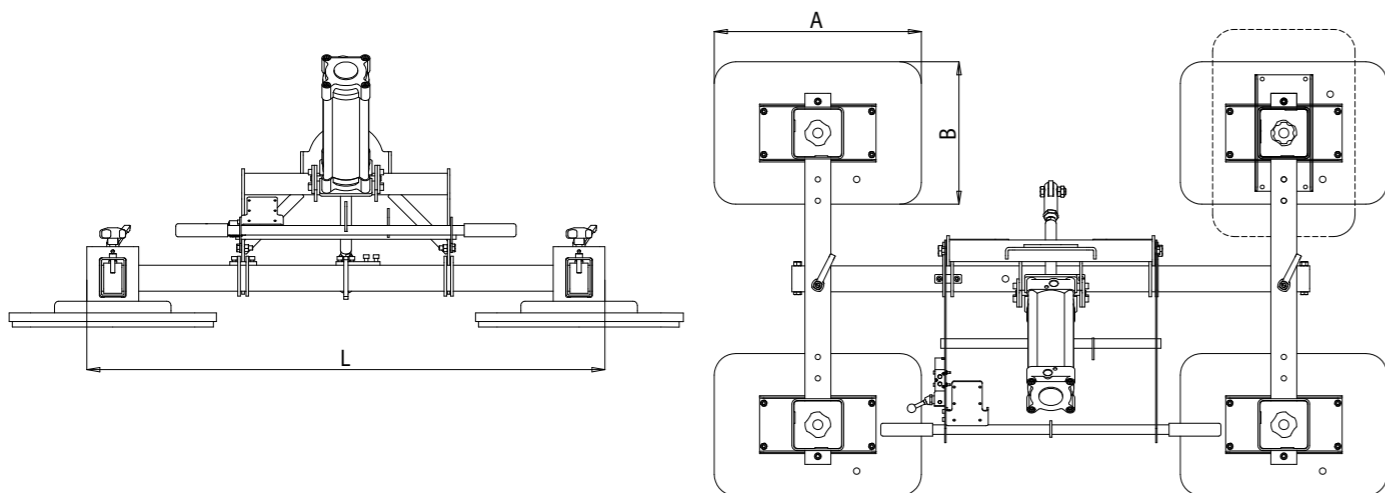

RIGHETTI has developed a series of vacuum lifters for marble and granite, specific for kitchen tops

With electric, battery or compressed air operating system. Those lifters are equipped with integrated tilting system to help customers on production area.

Based on customer needs and on the power supply available, the tilting system can be manual, or assisted by pneumatic or oil-hydraulic cylinders.

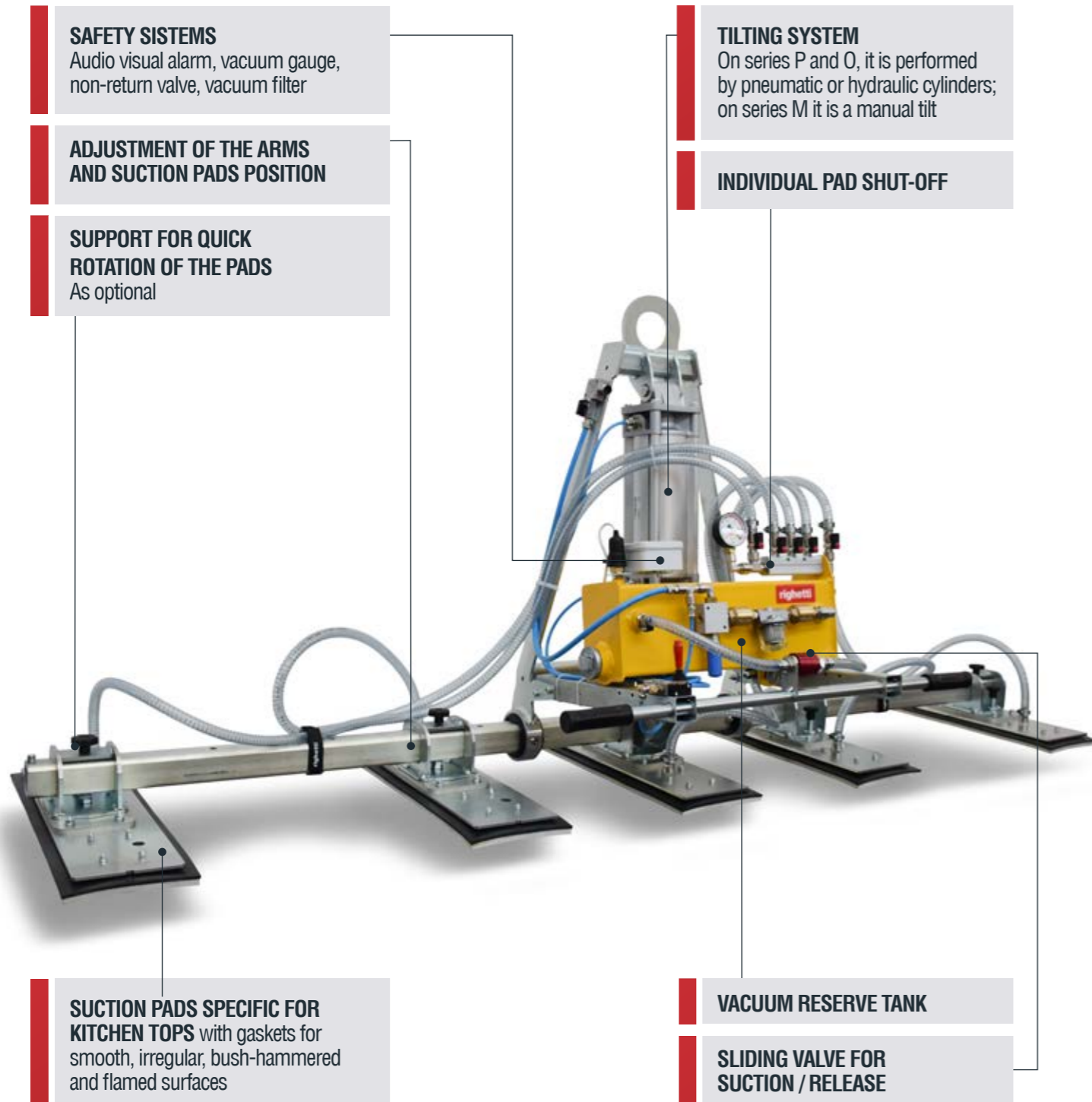

Vacuum lifters specific for kitchen tops



Electrically powered



Compressed air (operating)



Battery powered



Pneumatic tilt 0-90°



Manual tilt 0-90°



Hydraulic tilt 0-90°

M3-K

Power supply



Pads no.

3



M3-K is specific for kitchen tops up to 330kg. These models have three suction pads and are available with three different operating systems: pneumatic, electric (with included or separated vacuum pump) and battery.

The manual tilting system allows the movement of the load from vertical to horizontal and vice-versa.



M3-K series

270 - 330 Kg

Power supply	Capacity Kg	Pads no.	Suction pads size (AxB) mm	Beam (L) mm	Model
Compressed-air	270	3	480 x 180	2200	M3A 270K
	330	3	580 x 180	2200	M3A 330K
Electrically powered with on-board pump	270	3	480 x 180	2200	M3EB 270K
	330	3	580 x 180	2200	M3EB 330K
Battery	270	3	480 x 180	2200	M3B 270K
	330	3	580 x 180	2200	M3B 330K

Technical drawings

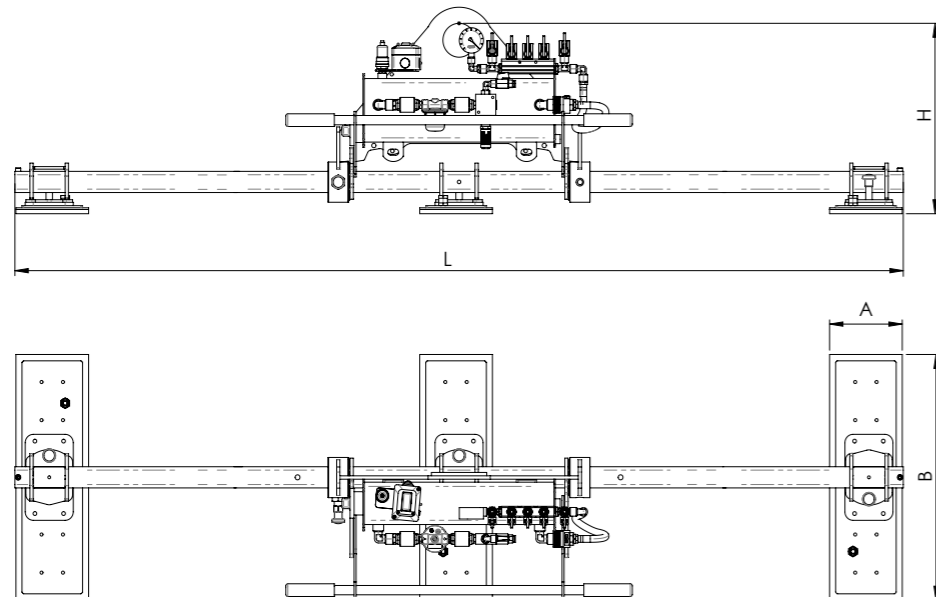

P3-K / O3-K

Power supply



Pads no.

3

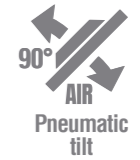

P3-K and O3-K series are specific for kitchen tops up to 330kg.

These models have three suction pads and are available with three different operating systems: compressed air with pneumatic tilting system (P3-K), electric or battery with electric tilt powered by a hydraulic cylinder (O3-K).



P3-K / O3-K series

270 - 330 Kg

Power supply	Capacity Kg	Pads no.	Suction pads size (AxB) mm	Cylinder no.	Beam (L) mm	Model
Compressed-air	270	3	480x180	1	2200	P3A 270K
	330	3	580x180	1	2200	P3A 330K
Electrically powered	270	3	480x180	1	2200	O3EB 270K
	330	3	580x180	1	2200	O3EB 330K
Battery	270	3	480x180	1	2200	O3B 270K
	330	3	580x180	1	2200	O3B 330K

Technical drawings

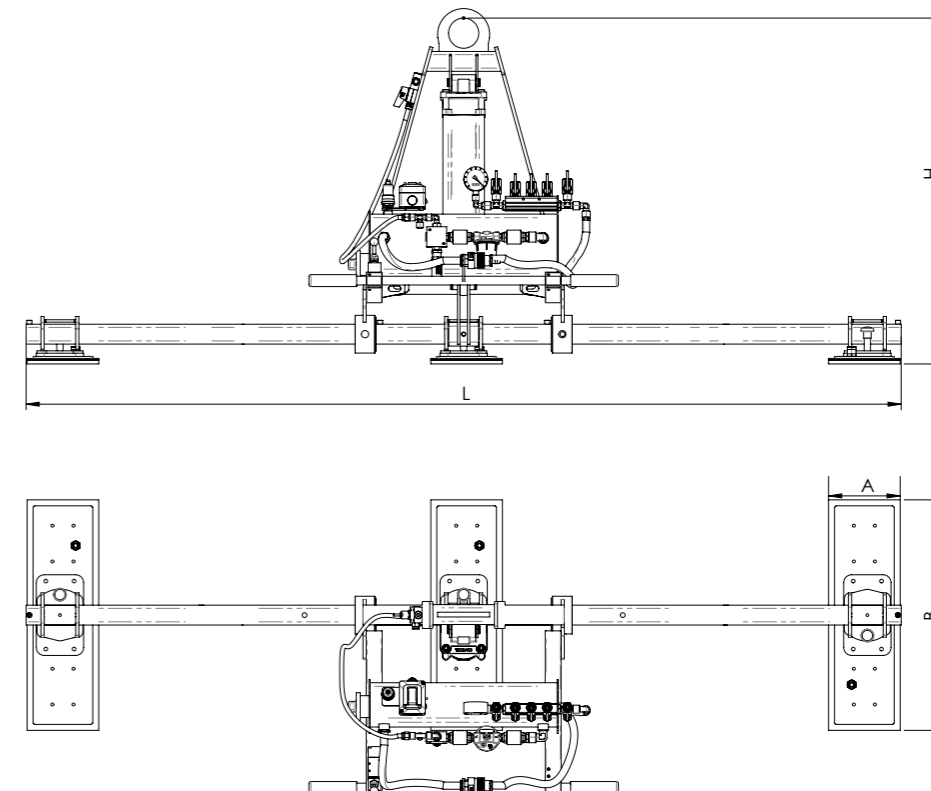

M4-K

Power supply



Pads no.

4



M4-K is specific for kitchen tops up to 440kg. These models have four suction pads and are available with three different operating systems: pneumatic, electric (with included or separated vacuum pump) and battery. The manual tilting system allows the movement of the load from vertical to horizontal and vice-versa.

M4-K series

360 - 440 Kg

Power supply	Capacity Kg	Pads no.	Suction pads size (AxB) mm	Beam (L) mm	Model
Compressed-air	360	4	480 x 180	2200	M4A 360K
	440	4	580 x 180	2200	M4A 440K
Electrically powered with on-board pump	360	4	480 x 180	2200	M4EB 360K
	440	4	580 x 180	2200	M4EB 440K
Battery	360	4	480 x 180	2200	M4B 270K
	440	4	580 x 180	2200	M4B 440K

Technical drawings

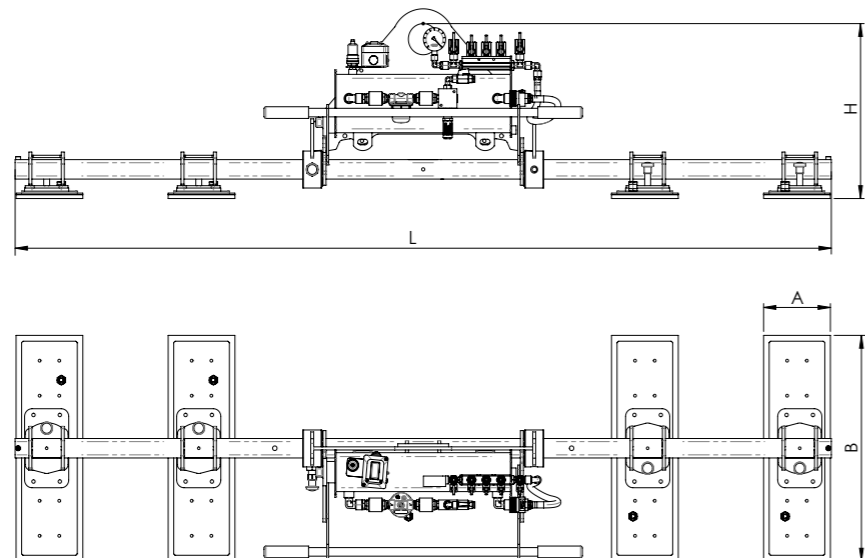

P4-K / 04-K

Power supply



Pads no.

4

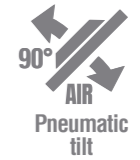

P4-K and 04-K are specific for kitchen tops up to 440kg. These models have three suction pads and are available with three different operating systems: compressed air with pneumatic tilting system (P4A-K), electric or battery with electric tilt powered by a hydraulic cylinder (04-K). The suction pads can be moved along the central beam to adapt to different size of the kitchen tops.

P4-K / 04-K series

360 - 440 Kg

Power supply	Capacity Kg	Pads no.	Suction pads size (AxB) mm	Cylinder no.	Beam (L) mm	Model
Compressed-air	360	4	480 x 180	1	2200	P4A 360K
	440	4	580 x 180	1	2200	P4A 440K
Electrically powered	360	4	480 x 180	1	2200	04EB 360K
	440	4	580 x 180	1	2200	04EB 440K
Battery	360	4	480 x 180	1	2200	04B 360K
	440	4	580 x 180	1	2200	04B 440K

Technical drawings

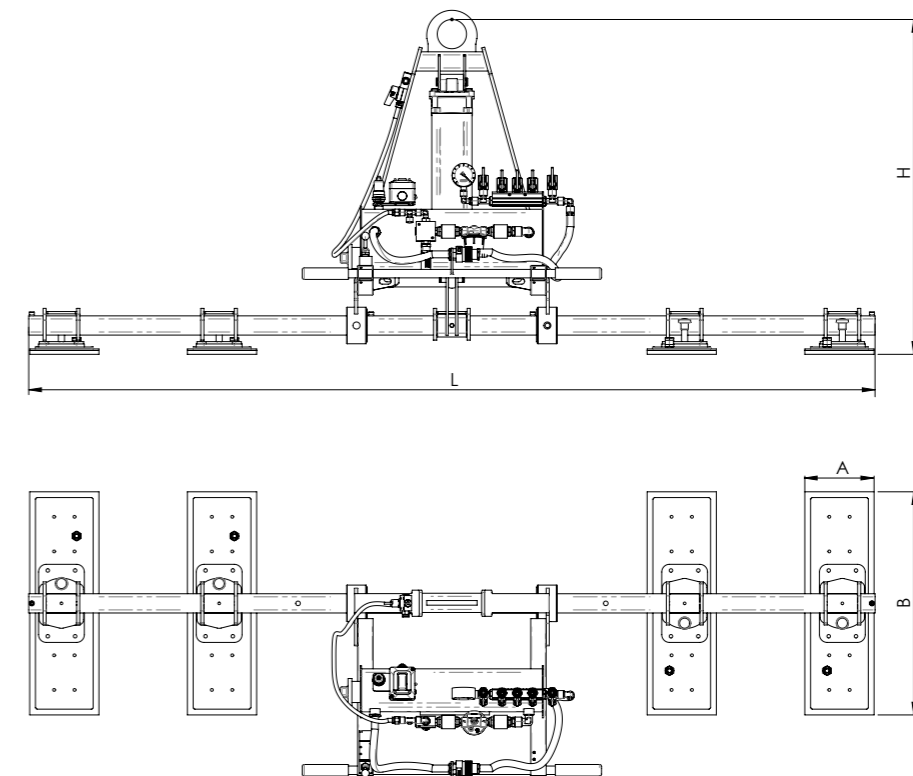

M5-K

Power supply



Pads no.

5



M5-K is specific for kitchen tops up to 550kg. These models have five suction pads and are available with three different operating systems: pneumatic, electric (with included or separated vacuum pump) and battery. The manual tilting system allows the movement of the load from vertical to horizontal and vice-versa.



Series M5-K

450 - 550 Kg

Power supply	Capacity Kg	Pads no	Suction pads size (AxB) mm	Beam (L) mm	Model
Compressed-air	450	5	480 x 180	2200	M5A 450K
	550	5	580 x 180	2200	M5A 550K
Electrically powered with on-board pump	450	5	480 x 180	2200	M5EB 450K
	550	5	580 x 180	2200	M5EB 550K
Battery	450	5	480 x 180	2200	M5B 450K
	550	5	580 x 180	2200	M5B 550K

Technical drawings

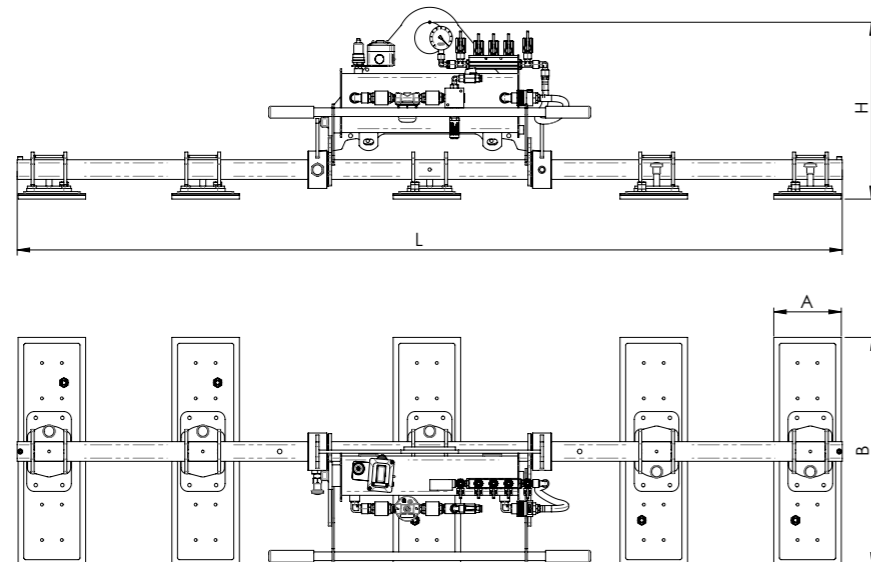

P5-K / O5-K

Power supply



Pads no.

5

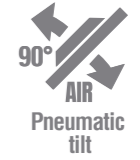

P5-K and O5-K are specific for kitchen tops up to 550kg. These models have five suction pads and are available with three different operating systems: compressed air with pneumatic tilting system (P5A-K), electric or battery with electric tilt powered by a hydraulic cylinder (O5-K). The suction pads can be moved along the central beam to adapt to different size of the kitchen tops.



Series P5-K/O5-K

450 - 550 Kg

Power supply	Capacity Kg	Pads no.	Suction pads size (AxB) mm	Cylinder no.	Beam (L) mm	Model
Compressed-air	450	5	480 x 180	1	2200	P5A 450K
	550	5	580 x 180	1	2200	P5A 550K
Electrically powered	450	5	480 x 180	1	2200	O5EB 450K
	550	5	580 x 180	1	2200	O5EB 550K
Battery	450	5	480 x 180	1	2200	O5B 450K
	550	5	580 x 180	1	2200	O5B 550K

Technical drawings

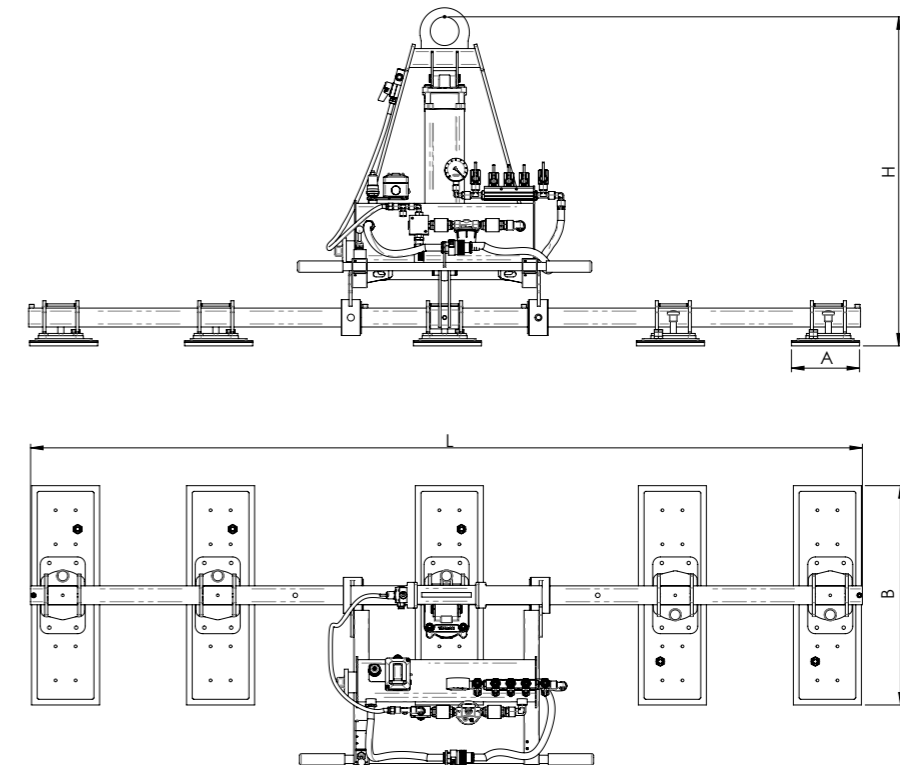

P5A625KX

Power supply
AIR Compressed-air

Pads no.
5

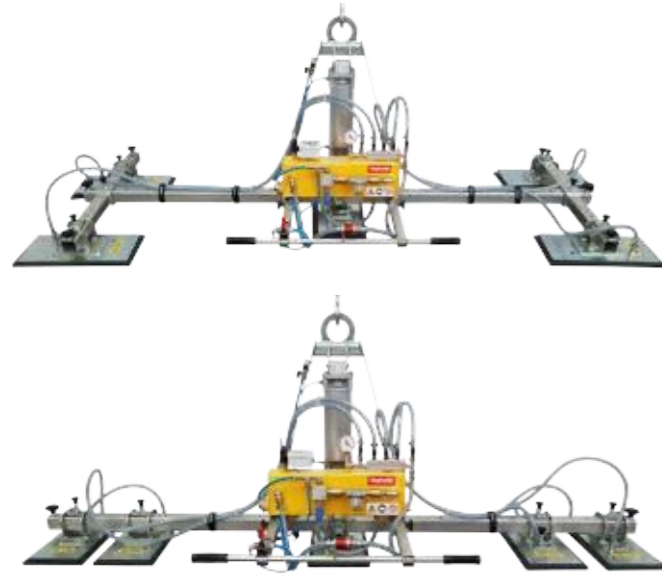
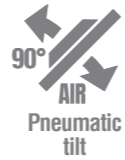

TRANSFORMABLE VACUUM LIFTER

The model P5A 625 KX is a vacuum lifter with 5 vacuum pads and a modular frame.

The structure, indeed, can be modified from in-line configuration to cross-pads configuration. In this way, with just one lifter it's possible to lift both kitchen tops and big slabs (even with irregular shape, thanks to the modularity of the pads).

When **in-line configuration**, the suction pads can be repositioned along the central beam.

When **in cross-pads configuration**, the pads can be adjusted along the arms. Moreover, the modularity of this lifter is demonstrate also by the possibility of rotate the pads from vertical to horizontal.

P5A625KX

625 Kg

Capacity Kg	Pads no.	Suction pads size (AxB) mm	Cylinder no.	Beam (L) mm	Model
625	5	480 x 180	1	2400	P5A625KX

Technical drawings

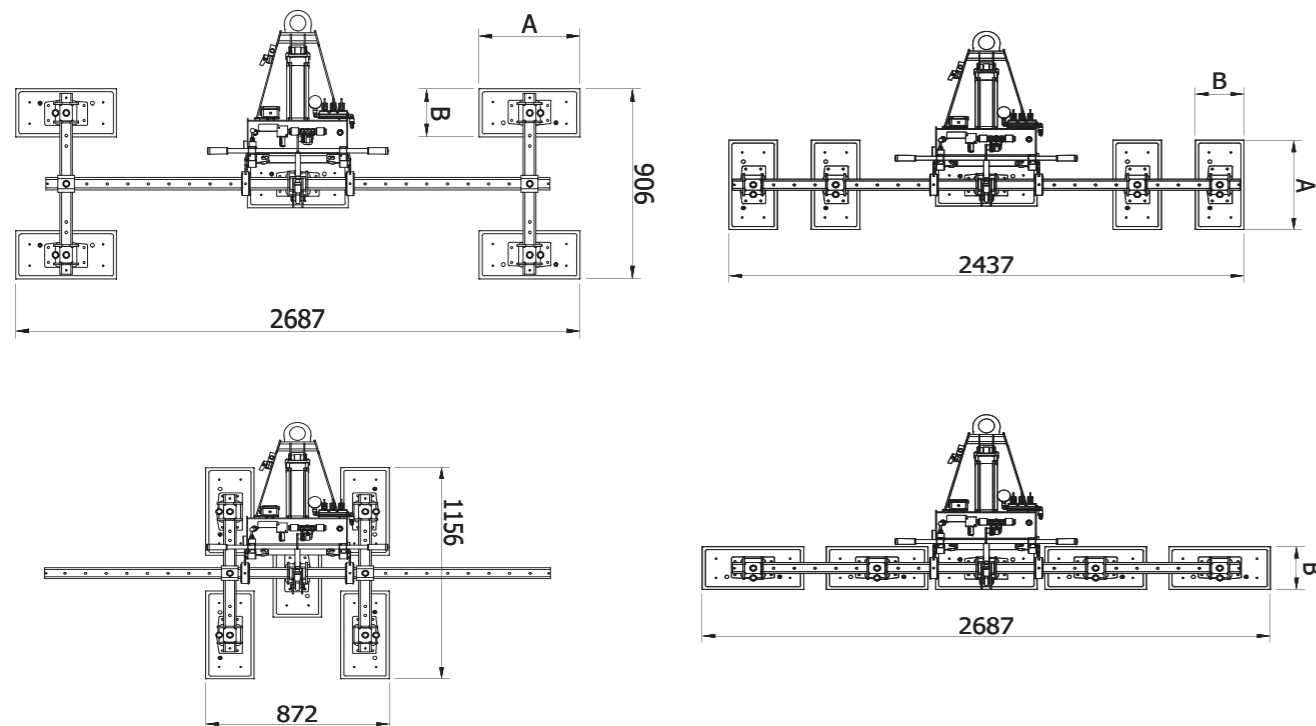

SF4K-PN

Power supply
AIR Compressed-air

Pads no.
4

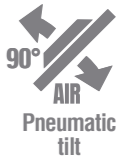

VACUUM LIFTER WITH LOWERED HEIGHT

SF series includes vacuum lifters equipped with four suction pads. The load can be easily tilted from horizontal to vertical position and viceversa thanks to the pneumatic tilt, which is aided by a pneumatic cylinder.

The lowered frame of the SF series allows for a considerable reduction in the below-the-hook height, resulting in easy handling even in low ceiling situations.

The suction pads can be rotated and repositioned along the central beam. *N.B: the model in the picture mounts spacers (available as optional, go to page 45 for more info)*

SF4K-PN

440 Kg

Capacity Kg	Pads no.	Suction pads size (AxB) mm	Cylinder no.	Beam (L) mm	Model
440	4	580 x 180	1	2400	SF4K-PN

Technical drawings

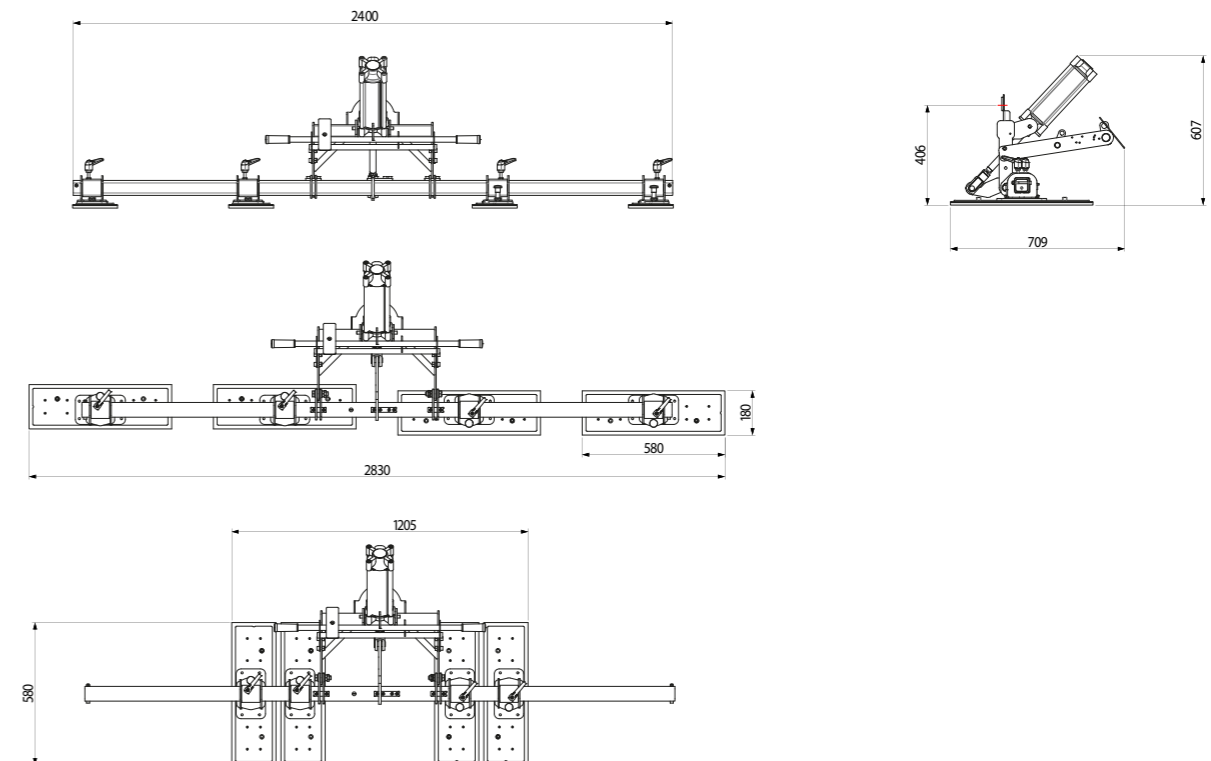

P4AK-RCM

Power supply
AIR Compressed-air

Pads no.
4

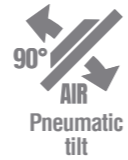

VACUUM LIFTER WITH 360° CONTINUOUS ROTATION

RCM series includes compressed-air vacuum lifters that allow not only the pneumatic tilt of the load but also its manual continuous rotation.

Rotating the loads eases its handling and its subsequent positioning during the processing phases.

The lifter is equipped with four rectangular suction pads which can be rotated and repositioned along the central beam.



Optional for kitchen top vacuum lifters

Lateral support suction pads

On every kitchen top model, lateral smaller supporting pads are available. The purpose of these suction pads is to give support to the entire length of the slab, even when the shape of the kitchen top provides limited spaces.



P4A-K-RCM series

360 - 440 Kg

Capacity Kg	Pads no.	Suction pads size (AxB) mm	Cylinder no.	Beam (L) mm	Model
360	4	480x180	1	2000	P4A360K-RCM
440	4	580x180	1	2000	P4A440K-RCM

Technical drawings

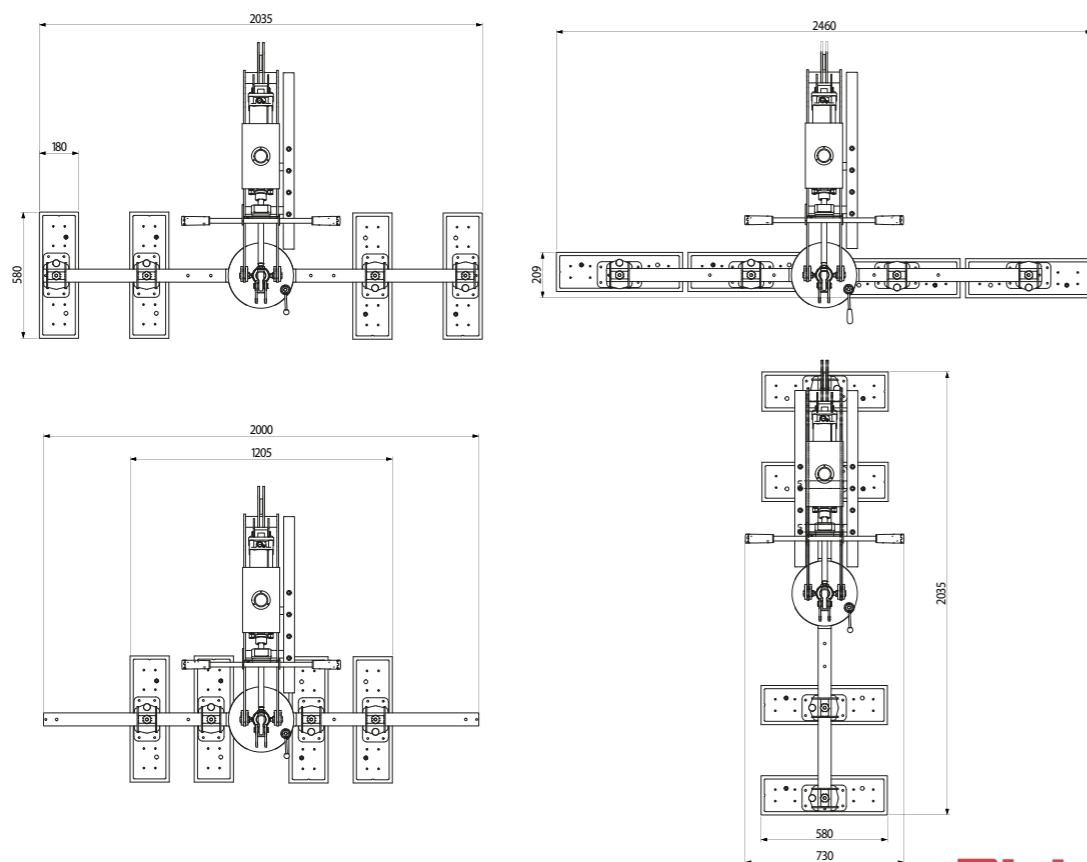

Suction pads with fast rotation

To adapt to all the possible sizes and shapes of the kitchen tops, it's possible to have, as optional, the system for the quick rotation of the pads. This feature comes in handy to speed up the rotation of the pads from vertical and horizontal, with possibility of keep them oblique.

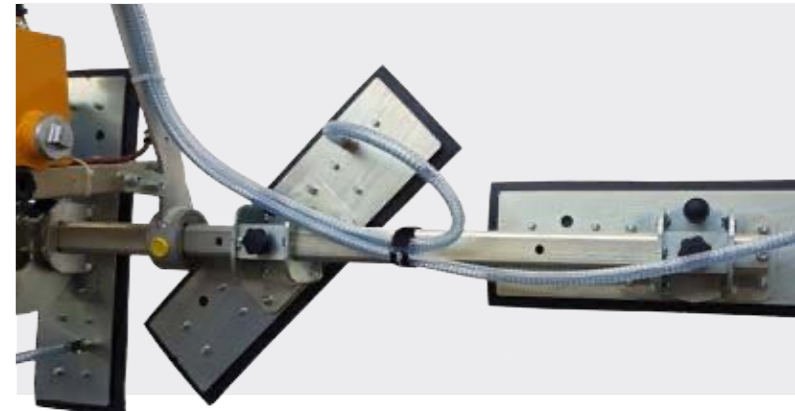

Long spacer mounts

Suction pads of the countertops vacuum lifters are customizable with spacer mounts, whose height increases the distance between the vacuum lifter and the load. This feature is helpful for example in case of kitchen countertops with a built-in sink.

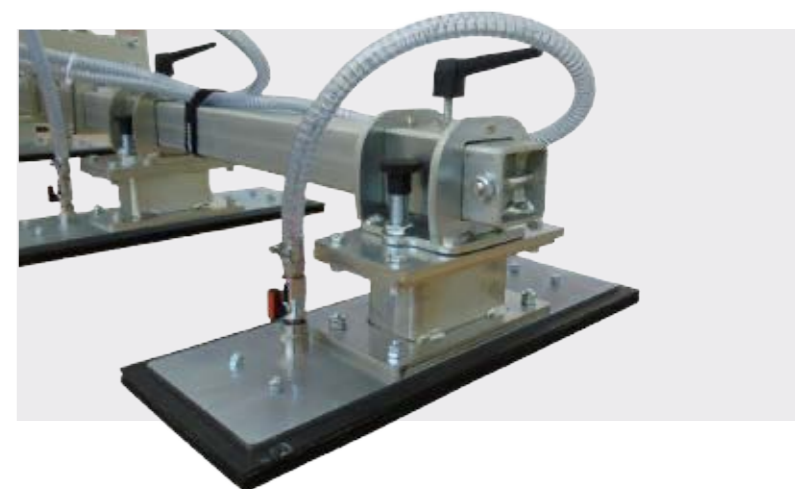

Discover the series of Righetti vacuum lifters specific for ceramic and Gres porcelain tiles

Working on the needs of our customers to lift and handle ceramic slabs, which are every day thinner and larger (consequently hard to lift with standard vacuum stone lifters), we have developed vacuum lifters model specific for porcelain slabs.

Generally, the tilting system on ceramic vacuum lifter is assisted by a cylinder to help and simplify the handling and lifting operations and to guarantee stability even to the thinnest slabs.

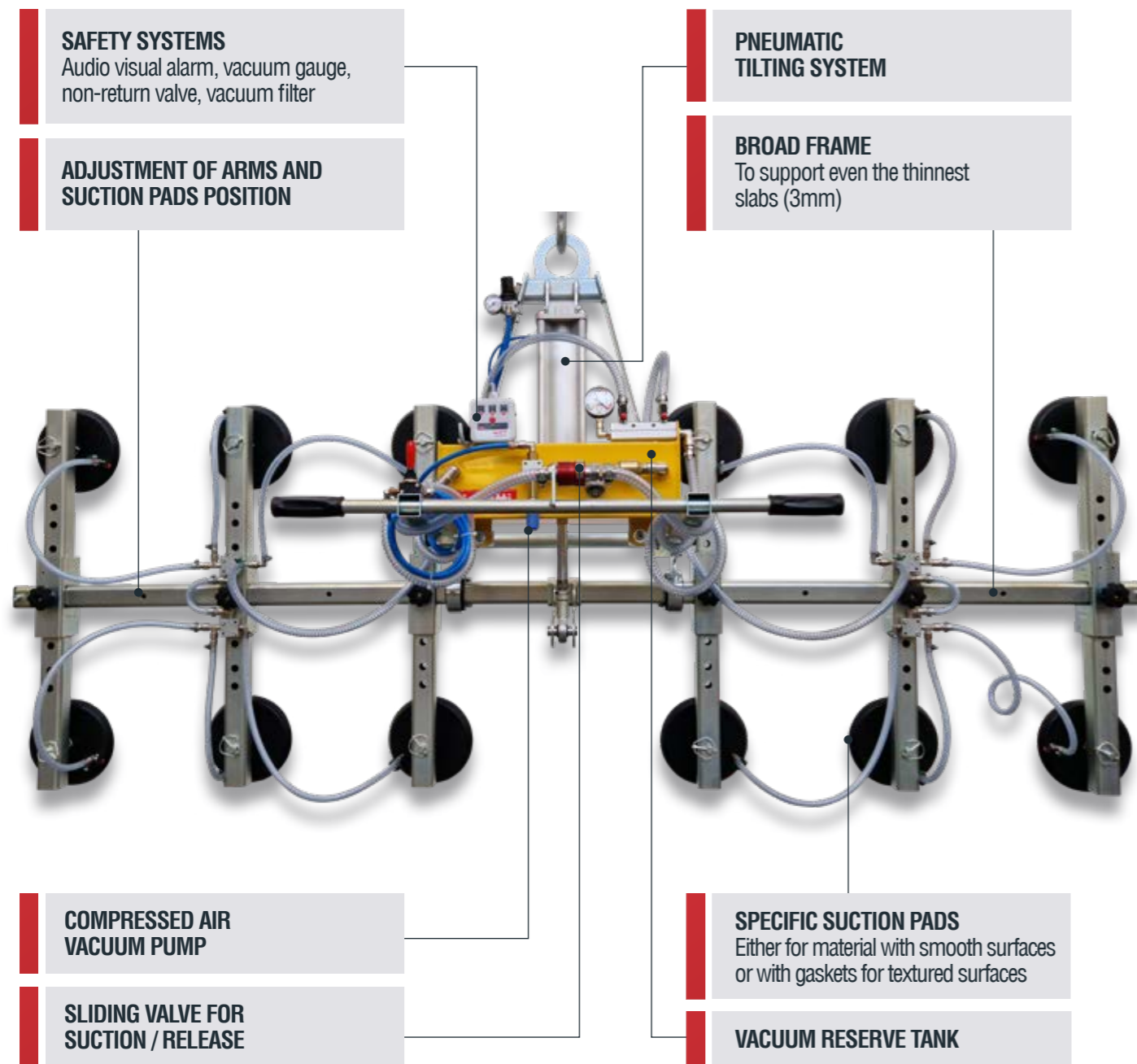

Vacuum lifters for ceramic slabs



Electrically powered



Compressed air (operating)



Battery powered



Pneumatic tilt 0-90°



Electric tilt 0-90°

Righetti
smart vacuum lifters

P8**E8**

Power supply



Pads no.

8

Electric tilt



Pneumatic tilt



P8 and E8 are vacuum lifters for lifting and handling ceramic slabs with capacity up to 300kg.

To guarantee the right support and stability to fragile materials, these vacuum lifters feature 8 vacuum pads, placed along all the structure. Based on the chosen operating system, the tilting can be pneumatic (series P8A) or electric (series E8).

P8 / E8 series **300 Kg**

Power supply	Capacity Kg	Pads no.	Suction pads size (AxB) mm	Arms (Y) mm	Beam (L) mm	Model
Compressed-air	300	8	200	830	2200	P8A300/2-2200/750
				1330		P8A300/2-2200/1270
Electrically powered	300	8	200	830	2200	E8EB300/2-2200/750
				1330		E8EB300/2-2200/1270
Battery	300	8	200	830	2200	E8B300/2-2200/750
				1330		E8B300/2-2200/1270

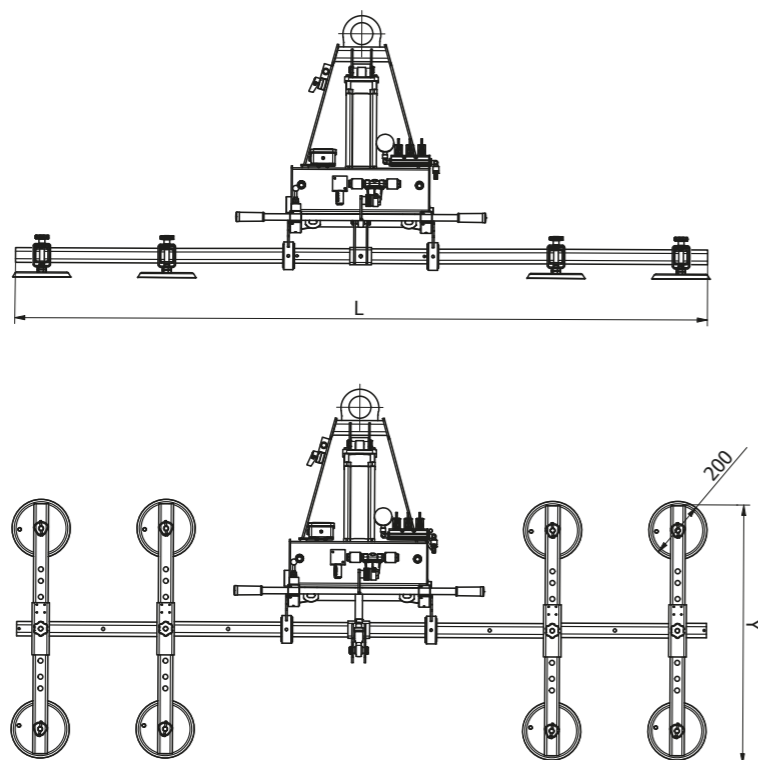
Technical drawings**P12****E12**

Power supply



Pads no.

12

Electric tilt

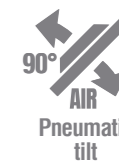

Pneumatic tilt

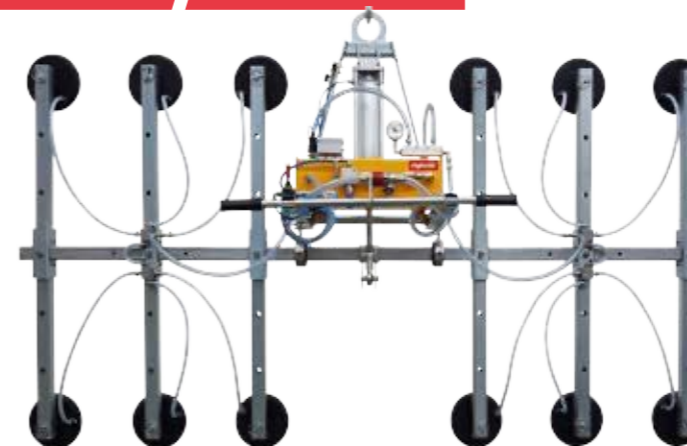

This is a series specific for lifting big porcelain slabs. It can be powered by electricity, batteries or compressed air.

The 12 suction pads and the frame of the lifter guarantee stability even with the thinnest ceramic slabs. Based on the chosen operating system, the tilting can be pneumatic or electric.

P12 / E12 series **350 Kg**

Power supply	Capacity Kg	Pads no.	Suction pads size (AxB) mm	Arms (Y) mm	Beam (L) mm	Model
Compressed-air	350	12	200	830	2500	P12A350/2-2500/750
				1330		P12A350/2-2500/1270
Electrically powered	350	12	200	830	2500	E12EB350/2-2500/750
				1330		E12EB350/2-2500/1270
Battery	350	12	200	830	2500	E12B350/2-2500/750
				1330		E12B350/2-2500/1270

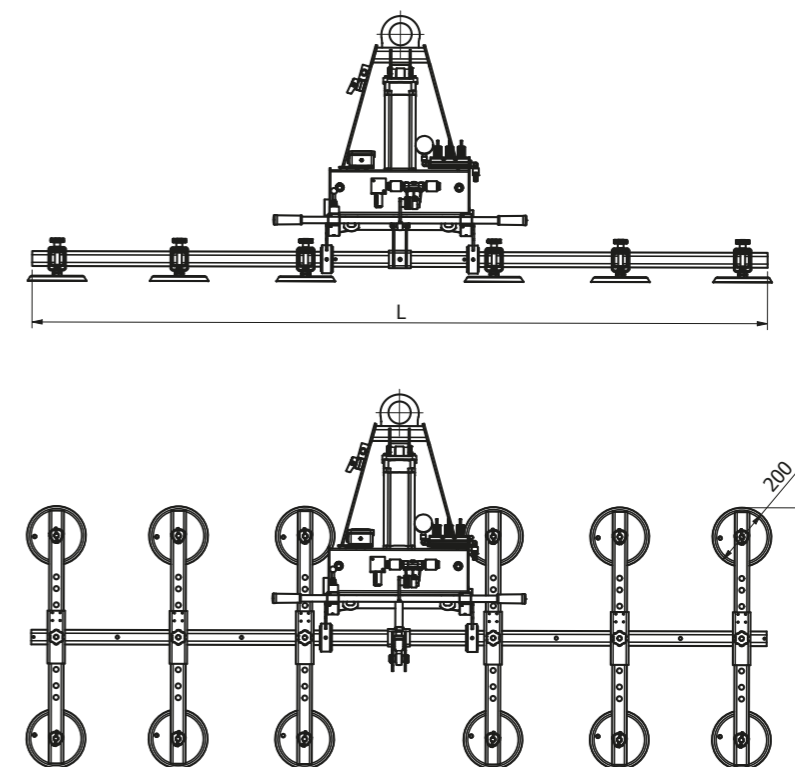
Technical drawings

P24A

Power supply
AIR Compressed-air

Pads no.
24

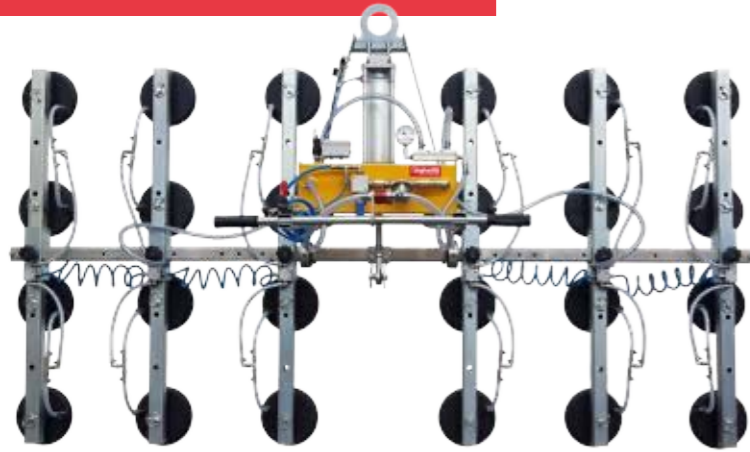
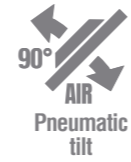

P24A is a vacuum lifter for lifting the most fragile ceramic slabs, with capacity up to 500kg. The central beam is 2500mm long and its 24 suction pads guarantee all the support needed to safeguard the integrity of the slab.

The pads can be moved along the arms, and the arms can be moved along the central beam.

P24A series

500 Kg

Power supply	Capacity Kg	Pads no.	Suction pads size (AxB) mm	Arms (Y) mm	Beam (Y) mm	Model
Compressed-air	500	24	200	1330	2500	P24A500/2 2500/1330

Technical drawings

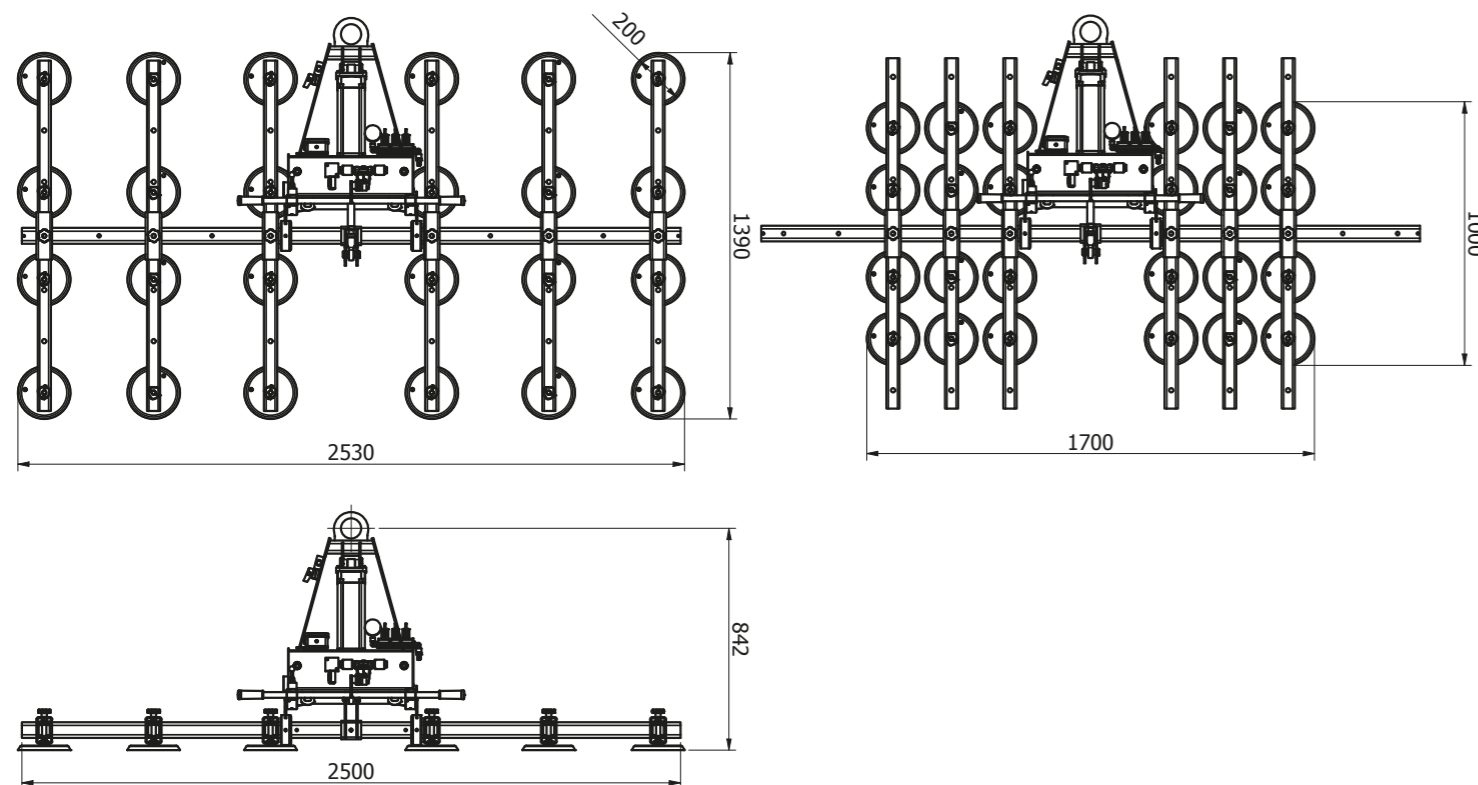

rihetti
smart vacuum lifters

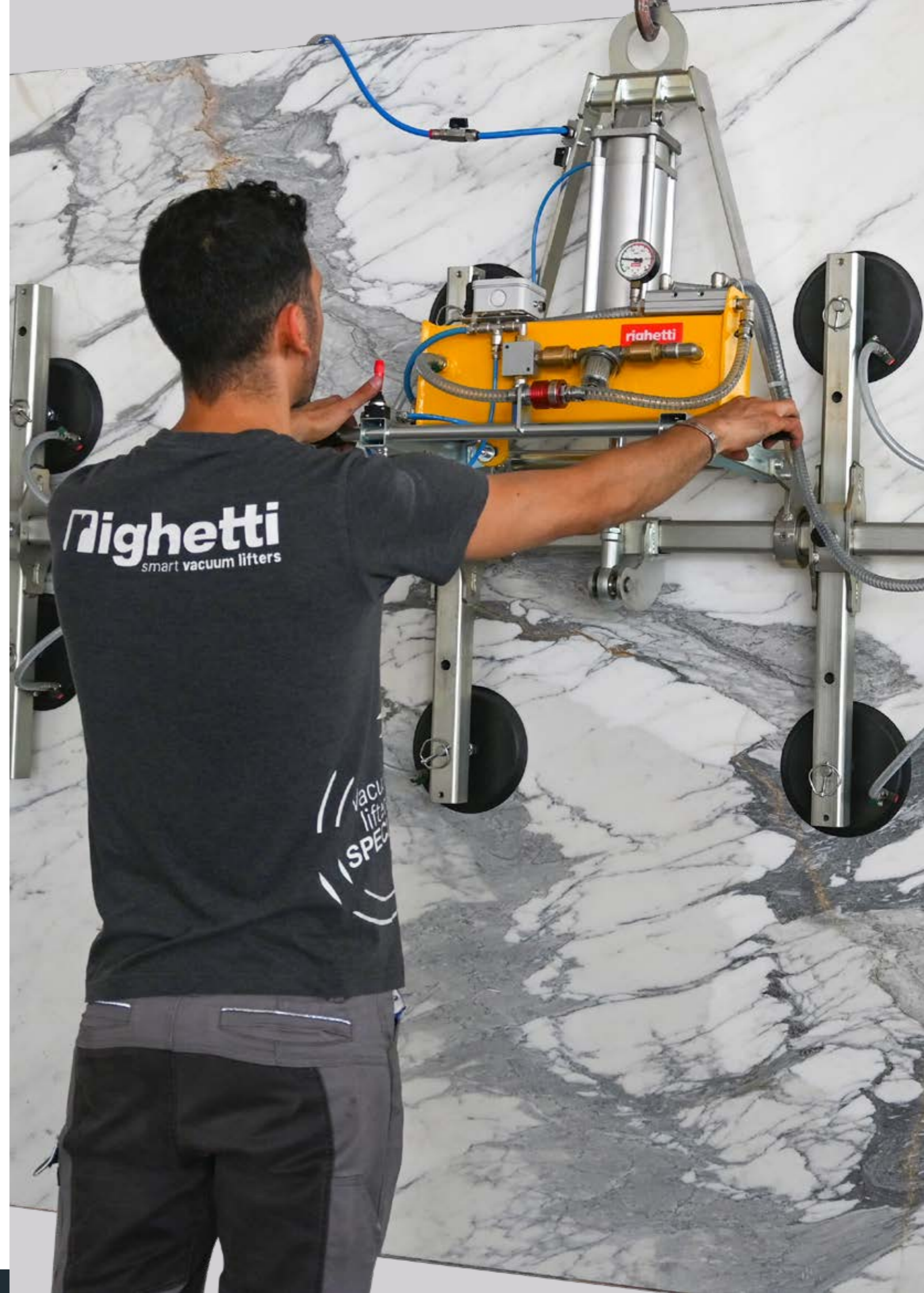

Vacuum lifters with electric operating system are the ideal solution for use on overhead crane or other lifting means where the pneumatic connection is not possible

On-board vacuum pumps are available with 400V three-phase or 220V single phase voltage. If not indicated, the lifter is produced with voltage 400V.

These vacuum lifters can be manufactured with one, two, three or four suction pads. In addition to standard models, Righetti can produce also customized and ad hoc solutions.

Tilting system can be either manual or electric depending on the requirements.

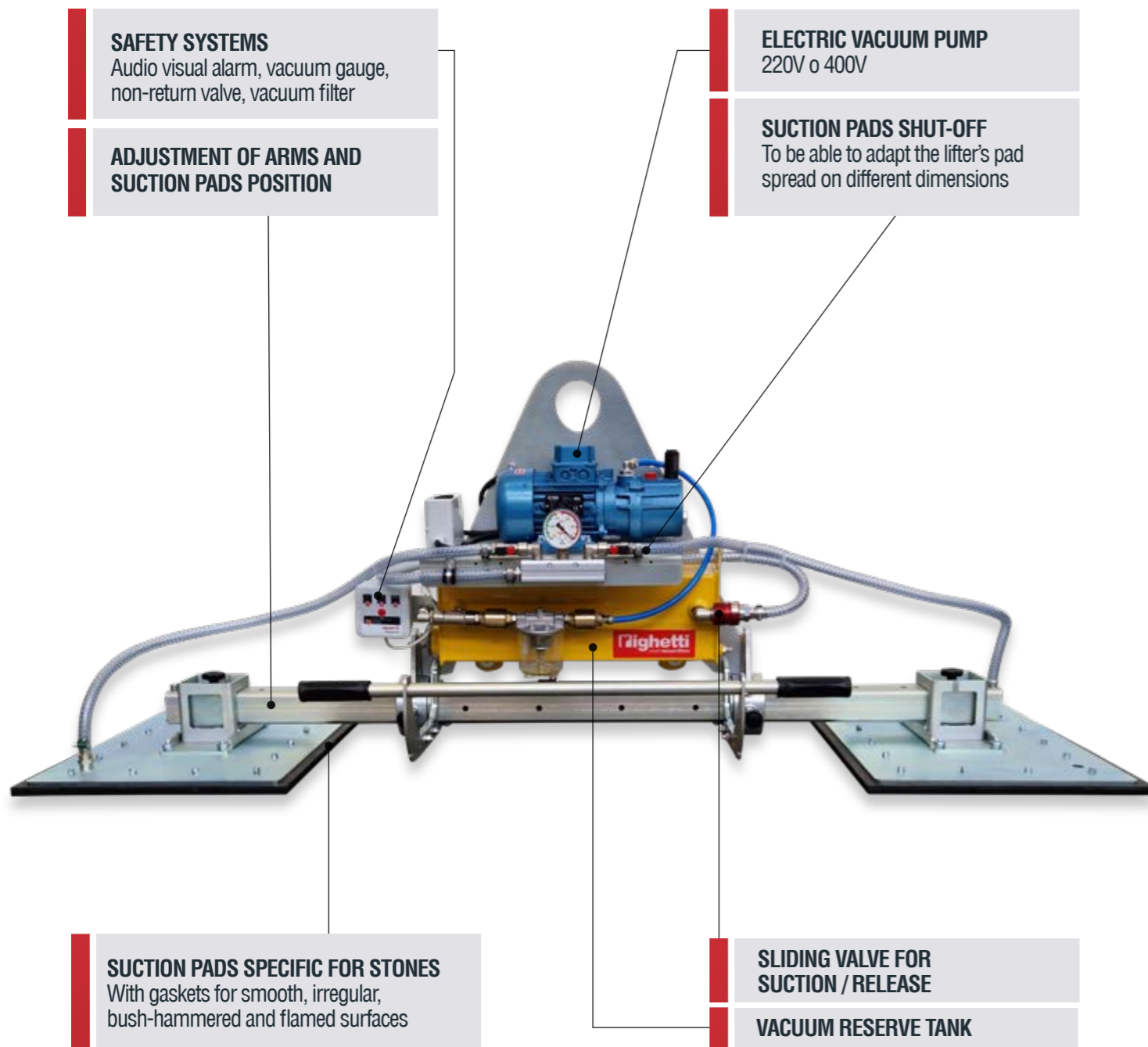

Stone vacuum lifters

electrically operated



Electrically powered



Manual tilt 0-90°



Hydraulic tilt 0-90°

M1EB / O1EB

Power supply
 **Electric**
 220V or 400V

Pads no.
1

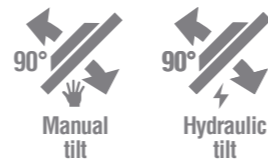

M1EB and O1EB are a series of vacuum lifters with lifting capacity up to 1000kg. These models are powered by electricity and it can be 220V single phase or 400V three-phases.

M1EB has manual tilting system, whereas O1EB has assisted tilting system powered by an oil-hydraulic cylinder.

M1EB / O1EB series

 **125 - 1000 Kg**

Capacity Kg	Pads no.	Suction pads size (AxB) mm	Manual tilt	Hydraulic tilt
			Model	Model
125	1	480 x 230	M1EB 125	O1EB 125
200	1	730 x 190	M1EB 200	O1EB 200
250	1	630 x 280	M1EB 250	O1EB 250
300	1	630 x 330	M1EB 300	O1EB 300
500	1	630 x 430	M1EB 500	O1EB 500
750	1	830 x 480	M1EB 750	O1EB 750
1000	1	960 x 530	M1EB 1000	O1EB 1000

Technical drawings

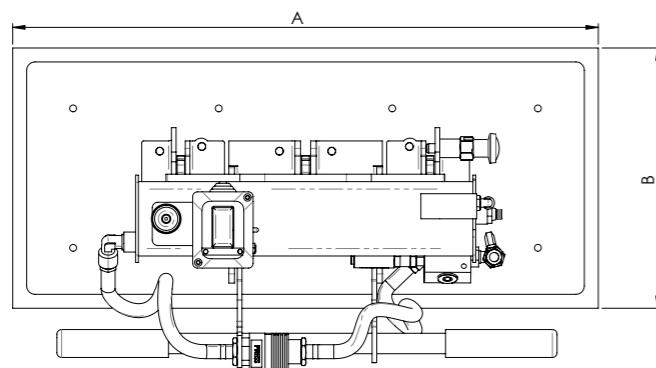

M2EB / O2EB

Power supply
 **Electric**
 220V or 400V

Pads no.
2

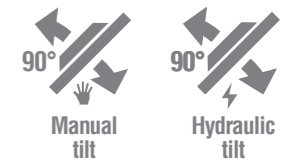

M2EB and O2EB are a series of vacuum lifters with lifting capacity up to 1500kg. These models are powered by electricity and it can be 220V single phase or 400V three-phases.

M2EB has manual tilting system, whereas O2EB has assisted tilting system powered by an oil-hydraulic cylinder.

M2EB / O2EB series

 **250 - 1500 Kg**

Capacity Kg	Pads no.	Suction pads size (AxB) mm	Manual tilt	Hydraulic tilt
			Model	Model
250	2	480 x 230	M2EB 250	O2EB 250
500	2	480 x 330	M2EB 500	O2EB 500
1000	2	630 x 430	M2EB 1000	O2EB 1000
1500	2	830 x 480	M2EB 1500	O2EB 1500

Technical drawings

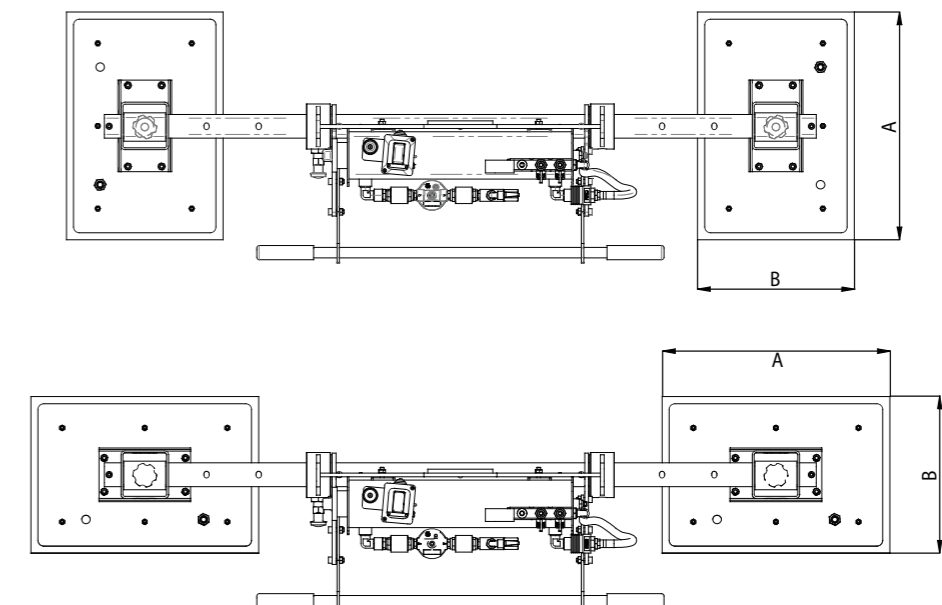

M3EB / O3EB

Power supply
 **Electric**
 220V or 400V

Pads no.
3

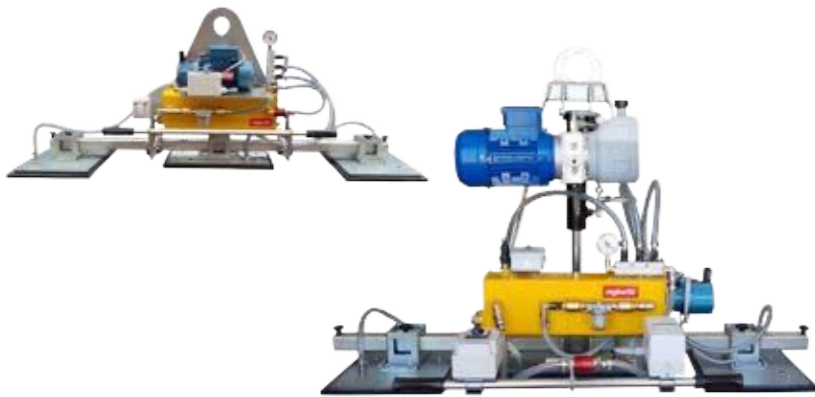
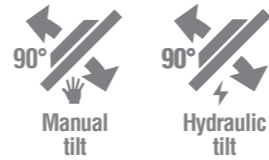

M3EB and O3EB are a series of vacuum lifters with lifting capacity up to 2000kg. These models are powered by electricity and it can be 220V single phase or 400V three-phases. In addition to the relocation of the lateral pads along the cross beam and their rotation, this model can be used also with the central pad only, to handle and lift loads of smaller dimensions.

M3EB has a manual tilting system, while O3EB has assisted tilting system powered by an oil-hydraulic cylinder.

M3EB / O3EB series

 **375 - 2000 Kg**

Capacity Kg	Pads no.	Suction pads size (AxB) mm		Manual tilt	Hydraulic tilt
		Central suction pad (A1xB1)	Lateral suction pads (AxB)	Model	Model
375	3	480 x 230	480 x 230	M3EB 375	O3EB 375
625	3	480 x 230	480 x 330	M3EB 625	O3EB 625
750	3	480 x 330	480 x 330	M3EB 750	O3EB 750
1000	3	630 x 330	630 x 330	M3EB 1000	O3EB 1000
1200	3	630 x 280	630 x 430	M3EB 1200	O3EB 1200
1500	3	630 x 430	630 x 430	M3EB 1500	O3EB 1500
2000	3	830 x 480	830 x 480	M3EB 2000	O3EB 2000

Technical drawings

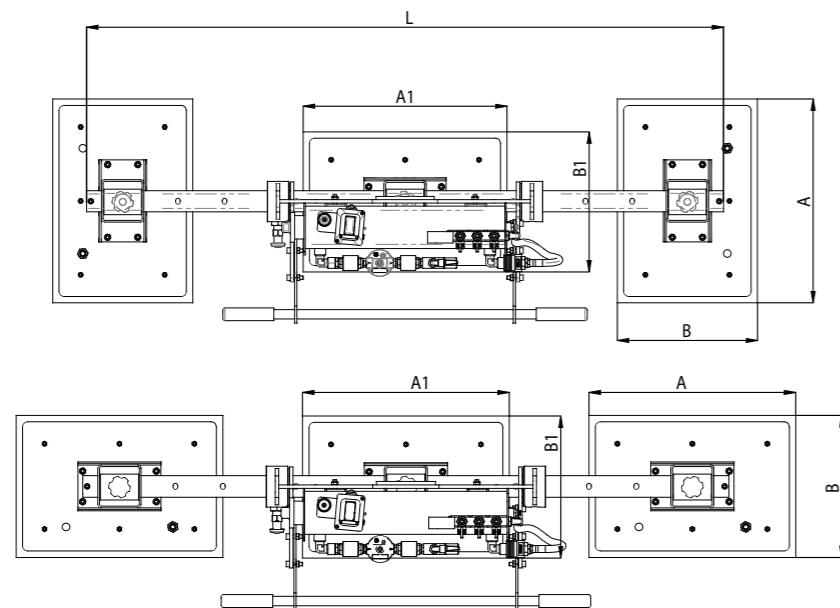

M4EB / O4EB

Power supply
 **Electric**
 220V or 400V

Pads no.
4

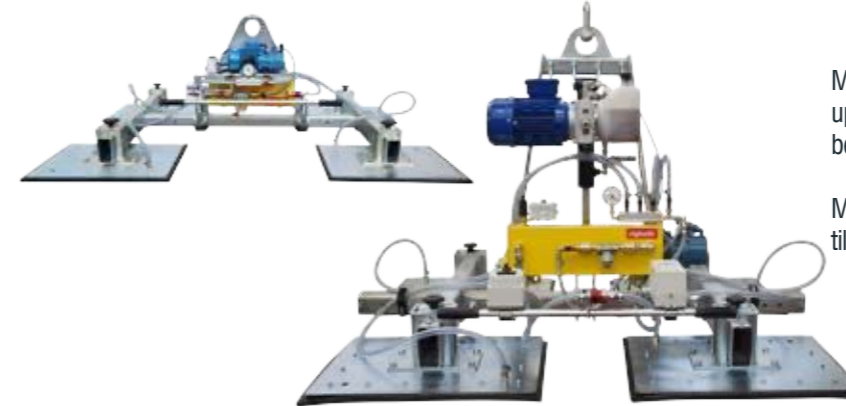
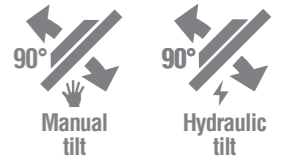

M4EB and O4EB are a series of vacuum lifters with lifting capacity up to 2000kg. These models are powered by electricity and it can be 220V single phase or 400V three-phases.

M4EB has manual tilting system, whereas O4EB has assisted tilting system powered by an oil-hydraulic cylinder.

M4EB / O4EB series

 **500 - 2000 Kg**

Capacity Kg	Pads no.	Suction pads size (AxB) mm	Manual tilt	Hydraulic tilt
			Model	Model
500	4	480 x 230	M4EB 500	O4EB 500
1000	4	480 x 330	M4EB 1000	O4EB 1000
1500	4	630x330	M4EB 1500	O4EB 1500
2000	4	630 x 430	M4EB 2000	O4EB 2000

Technical drawings

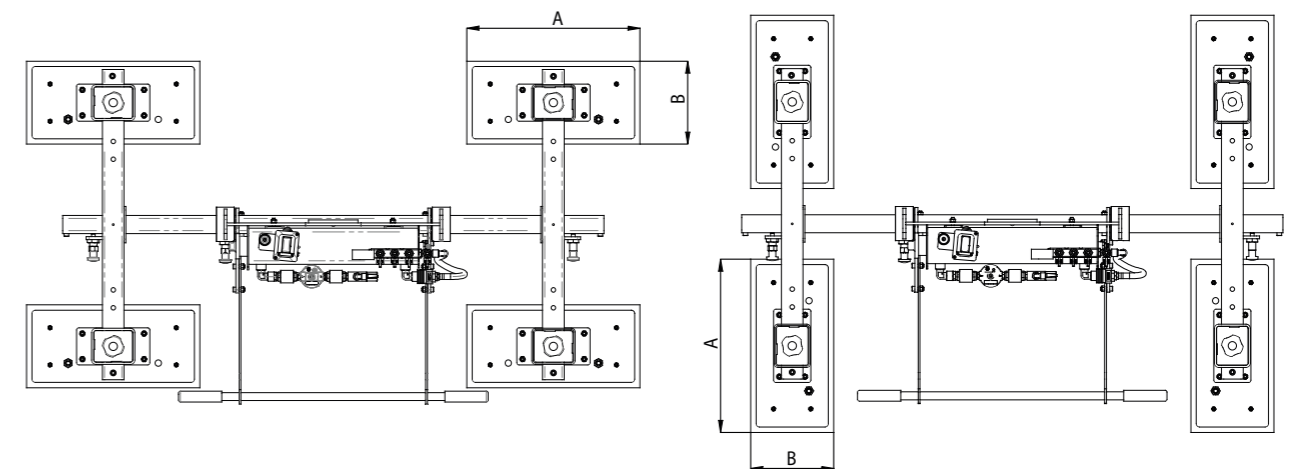

The vacuum lifters powered by on-board rechargeable batteries are the solution to work in those locations where the connection to power source is not possible

Battery powered vacuum lifters are equipped with all the technologies needed to guarantee safety of the load and the operators. An advanced control unit manages all the lifter activities, verifies the correct functioning of all the components and performs a self-diagnosis to discover potential malfunctions.

The vacuum control unit supervise the level of vacuum, reporting any possible problems with an audio-visual alarm, showing the power level of batteries by a constant check of the batteries status.

SAFETY SYSTEMS

Audio visual alarm, vacuum gauge, non-return valve, vacuum filter

VACUUM CONTROL UNIT

Equipped with a battery status indicator which always shows the level of charge, and an economizer to optimize the duration of the batteries

RECHARGEABLE BATTERY

VACUUM PUMP POWERED BY BATTERIES

SLIDING VALVE FOR SUCTION / RELEASE

SUCTION PADS SPECIFIC FOR STONES

With gaskets for smooth, irregular, bush-hammered and flamed surfaces

VACUUM RESERVE TANK

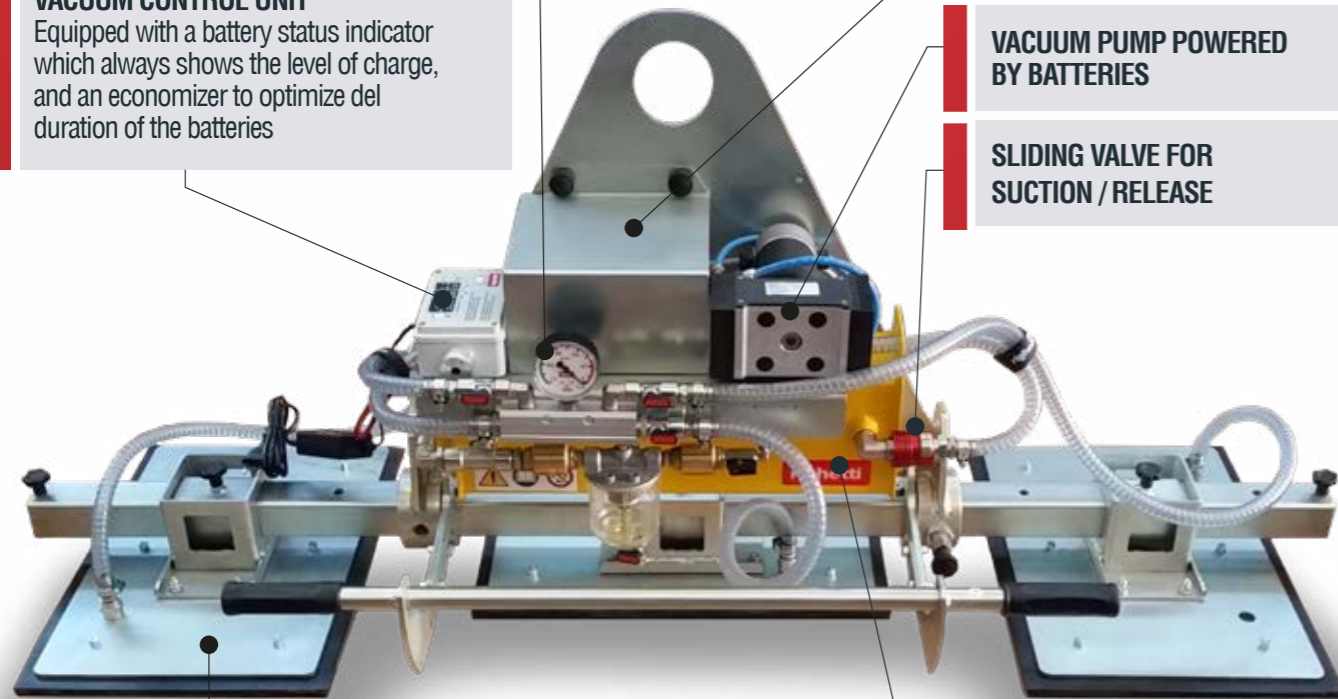

Stone vacuum lifters

battery powered



Battery powered



Manual tilt 0-90°



Hydraulic tilt 0-90°

M1B / O1B

Power supply
 Battery

Pads no.
1

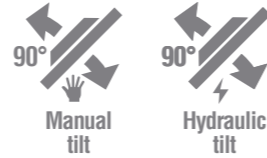

M1B and O1B are a series of battery powered vacuum stone lifter with one pad and lifting capacity up to 1000kg. The vacuum control unit indicates the battery level, always assuring the correct use of the lifter.

M1B has manual tilting system, while O1B has assisted tilting system powered by an oil-hydraulic cylinder.

M1B / O1B series

 **125 - 1000 Kg**

Capacity Kg	Pads no.	Suction pads size (AxB) mm	Manual tilt	Hydraulic tilt
			Model	Model
125	1	480 x 230	M1B 125	O1B 125
200	1	730 x 190	M1B 200	O1B 200
250	1	630 x 280	M1B 250	O1B 250
300	1	630 x 330	M1B 300	O1B 300
500	1	630 x 430	M1B 500	O1B 500
750	1	830 x 480	M1B 750	O1B 750
1000	1	960 x 530	M1B 1000	O1B 1000

Technical drawings

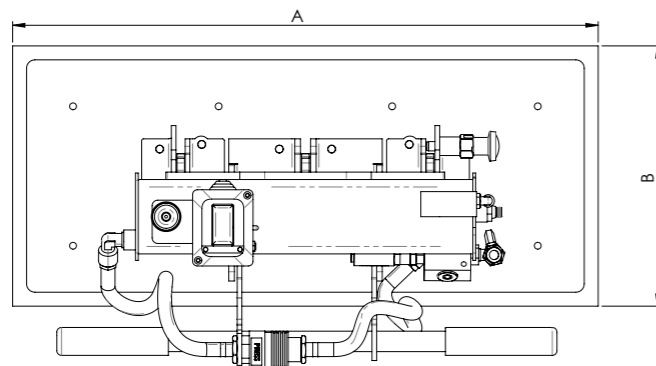

M2B / O2B

Power supply
 Battery

Pads no.
2

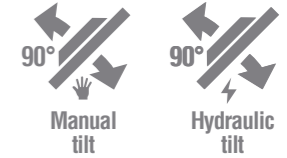

M2B and O2B are a series of battery powered vacuum stone lifter with two pads and lifting capacity up to 1500kg. The vacuum control unit indicates the battery level, always assuring the correct use of the lifter.

M2B has manual tilting system, whereas O2B has assisted tilting system powered by an oil-hydraulic cylinder.

M2B / O2B series

 **250 - 1500 Kg**

Capacity Kg	Pads no.	Suction pads size (AxB) mm	Manual tilt	Hydraulic tilt
			Model	Model
250	2	480 x 230	M2B 250	O2B 250
500	2	480 x 330	M2B 500	O2B 500
1000	2	630 x 430	M2B 1000	O2B 1000
1500	2	830 x 480	M2B 1500	O2B 1500

Technical drawings

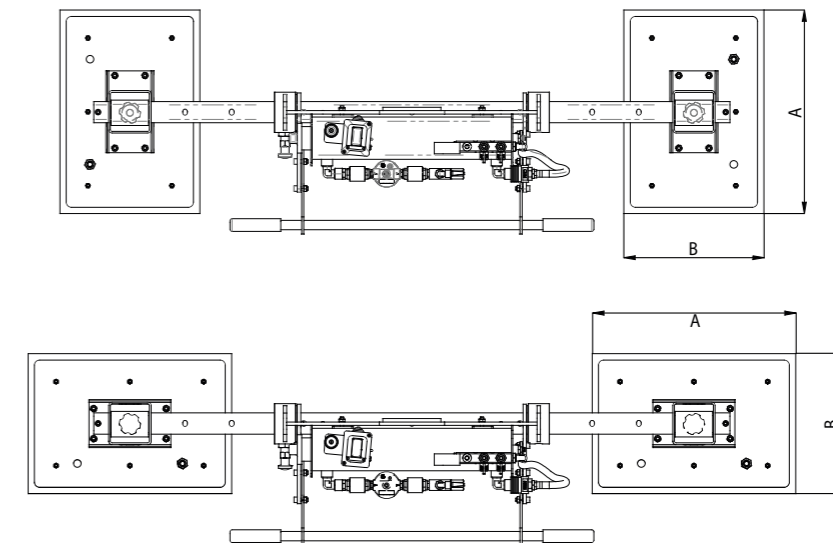

M3B / O3B

Power supply



Pads no.

3

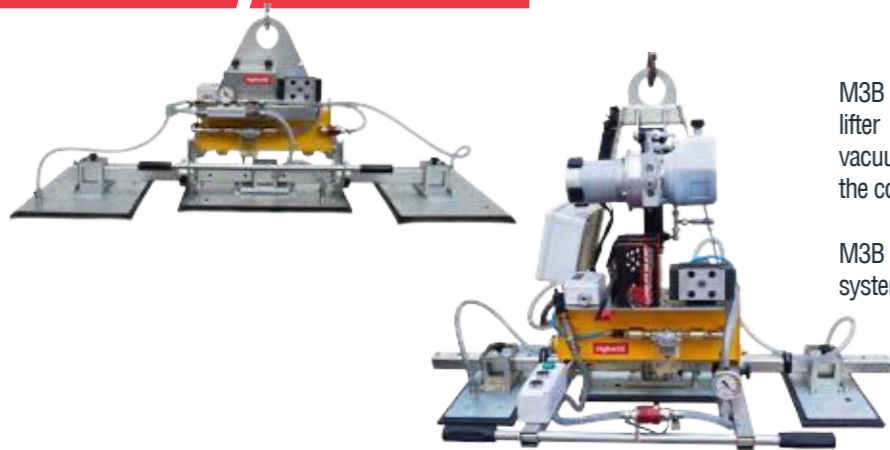
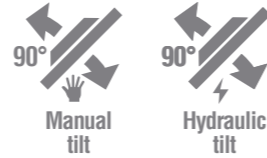

M3B and O3B are a series of battery powered vacuum stone lifter with three pads and lifting capacity up to 2000kg. The vacuum control unit indicates the battery level, always assuring the correct use of the lifter.

M3B has manual tilting system, whereas O3B has assisted tilting system powered by an oil-hydraulic cylinder.

M3B / O3B series

375 - 2000 Kg

Capacity Kg	Pads no.	Suction pads size (AxB) mm		Manual tilt	Hydraulic tilt
		Central suction pad (A1xB1)	Lateral suction pads (AxB)	Model	Model
375	3	480 x 230	480 x 230	M3B 375	O3B 375
625	3	480 x 230	480 x 330	M3B 625	O3B 625
750	3	480 x 330	480 x 330	M3B 750	O3B 750
1000	3	630 x 330	630 x 330	M3B 1000	O3B 1000
1200	3	630 x 280	630 x 430	M3B 1200	O3B 1200
1500	3	630 x 430	630 x 430	M3B 1500	O3B 1500
2000	3	830 x 480	830 x 480	M3B 2000	O3B 2000

Technical drawings

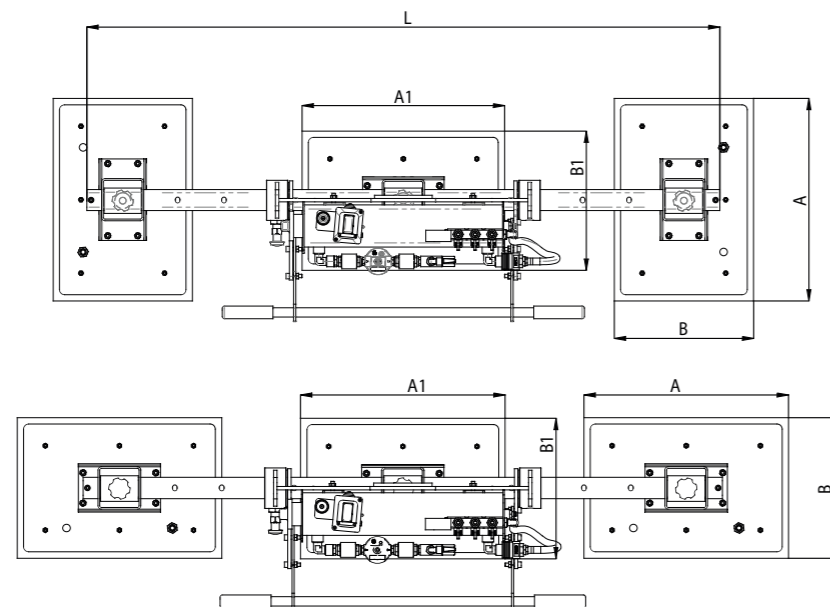

M4B / O4B

Power supply



Pads no.

4

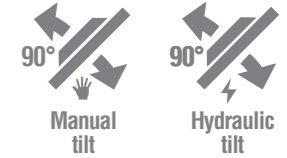

M4B and O4B are a series of battery powered vacuum stone lifter with four pads and lifting capacity up to 2000kg. The vacuum control unit indicates the battery level, always assuring the correct use of the lifter.

M4B has manual tilting system, whereas O4B has assisted tilting system powered by an oil-hydraulic cylinder.

M4B / O4B series

500 - 2000 Kg

Capacity Kg	Pads no.	Suction pads size (AxB) mm	Manual tilt	Hydraulic tilt
			Model	Model
500	4	480 x 230	M4B 500	O4B 500
1000	4	480 x 330	M4B 1000	O4B 1000
1500	4	630x330	M4B 1500	O4B 1500
2000	4	630 x 430	M4B 2000	O4B 2000

Technical drawings

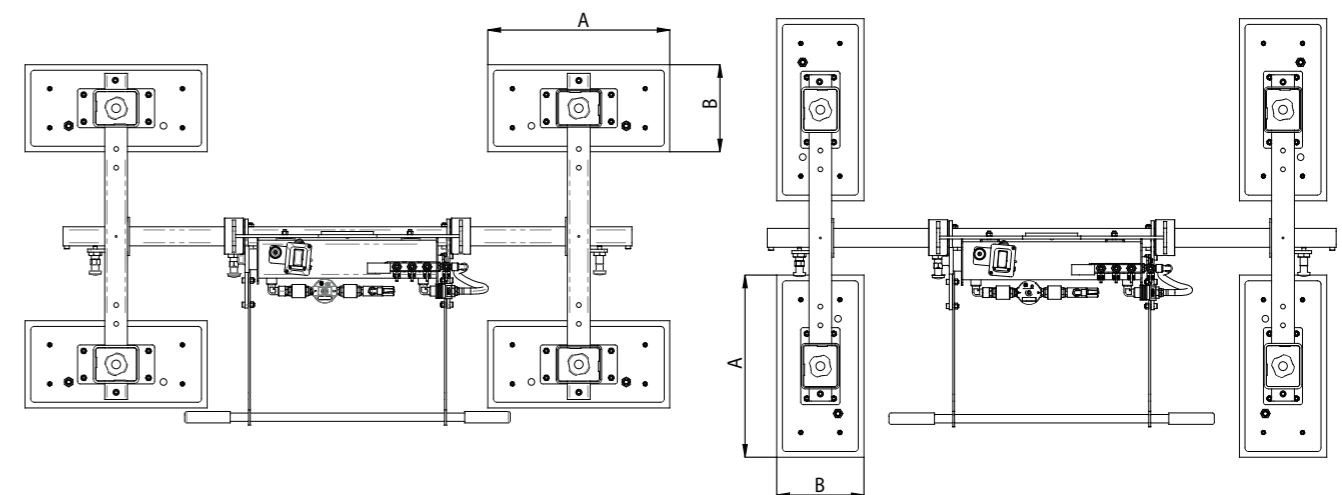

S1 series is the ideal solution to work in outdoor environments, thanks to its autonomous power source

Designed for outdoor use and for simplifying your job, S1 is the series of compact and light vacuum lifters which allow to interchange pads easily, offering the possibility of lifting materials of different dimensions and surfaces, like stones, concrete, marble and many others.

The vacuum control unit constantly monitors the level of vacuum in the circuit and, altogether with the economizer, guarantees the optimization of the battery.

SAFETY SYSTEMS

Audio visual alarm, vacuum gauge, non-return valve, vacuum filter

SLIDING VALVE FOR SUCTION / RELEASE



VACUUM PAD WITH SPECIFIC GASKETS

For smooth, slightly irregular, bush-hammered or flamed surfaces

INTERCHANGEABLE VACUUM PADS

VACUUM RESERVE TANK

Stone vacuum lifters specific for outdoor use



Manually powered



Compressed air (operating)



Battery powered



Manual tilt 0-90°

S1-MP

Power supply
AIR

Pads no.
1

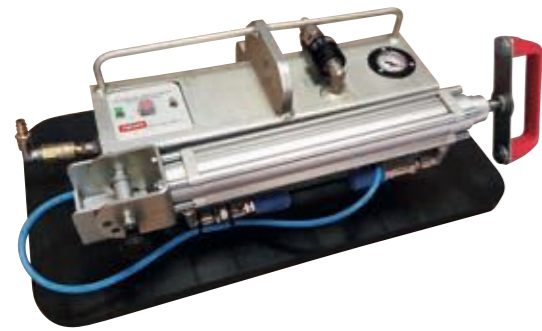

S1 is a series of light and compact vacuum lifters.

The S1-MP model has dual possibility of operating: it can be connected to compressed air or the vacuum can be created by manually pushing the pump that allows its use in full autonomy, without need of constant connection to power supply.

Thanks to the interchangeable pads, this model can have lifting capacity up to 1000kg.

S1-B

Power supply
Battery

Pads no.
1



S1-B is battery powered, easy to change and to recharge. It is perfect for all outdoor stone applications, all on its own and with versatility based on needs. The dimensions of the suction pads allow S1-B to have a lifting capacity up to 600kg.

S1-MP series

max 1000 kg

Capacity Kg	Pads no.	Tare kg	Suction pads size (AxB) mm		Model
			Equipment	To be added	
Max 600 kg	1	18	-	Pad of the category A	S1-MP-600.2
Max 800 kg	1	26	830x420 (cat. B)	Pad of the category A	S1-MP-800
Max 1000 kg	1	32	900x480 (cat. C)	Pad of the category A	S1-MP-1000

S1-B series

Max 600 kg

Capacity Kg	Pads no.	Tare kg	Suction pads size (AxB) mm		Model
			Equipment	To be added	
Max 600 kg	1	26	-	Pad of the category A	S1-B

Available suction pads

Category	Capacity Kg		Pad dimensions mm		Product code	Model			
	horizontal	vertical	X	Y		S1-MP-600	S1-MP-800	S1-MP-1000	S1-B
A	50	-	450	100	S1-450100	•	•	•	•
	100	-	250	250	S1-250250	•	•	•	•
		-	660	100	S1-660100	•	•	•	•
	200	100	760	150	S1-760150	•	•	•	•
	250	125	480	230	S1-480230	•	•	•	•
	300	150	760	200	S1-760200	•	•	•	•
	450	225	630	330	S1-630330	•	•	•	•
B	800	400	830	420	S1-830420	-	included	•	-
C	1000	500	900	480	S1-900480	-	-	included	-

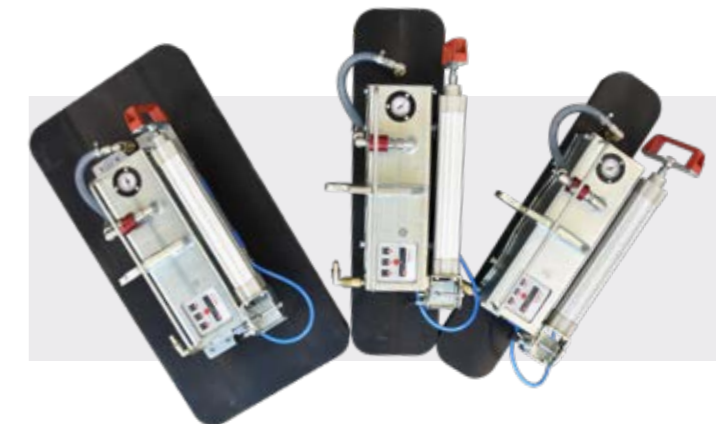

• Available | - Not available | **Included** standard feature
To order please indicate the model of the vacuum lifter and the desired suction pad

Technical drawings

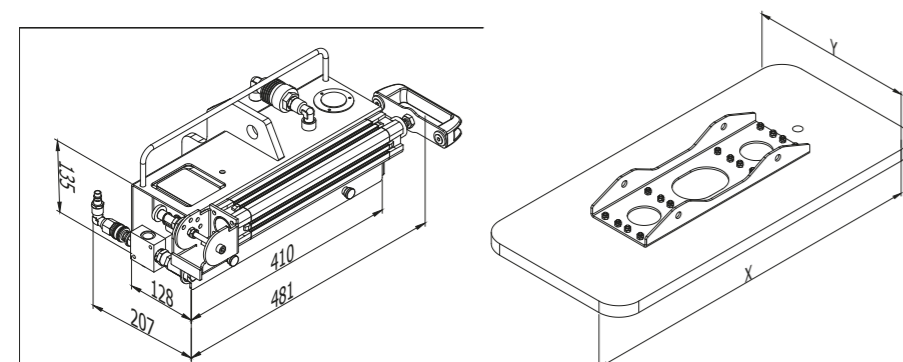

Technical drawings

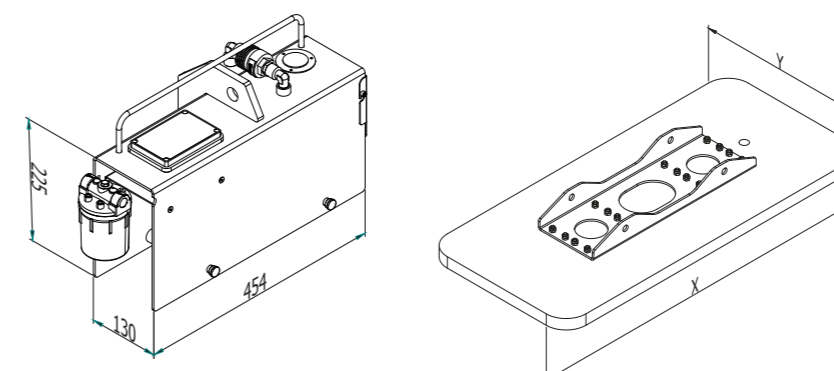

Optional accessories for S1 series

Interchangeable suction pads

The peculiarity of S1 series is the interchangeability of its suction pad to **adapt the dimensions and lifting capacity** to the load. The suction pads whose lifting capacity goes from 50 to 600kg (A category), can be mounted both on S1-B and S1-MP, while those with 800kg e 1000kg capacity are compatible only with S1-MP model.

Check the chart in the previous pages to find the best model for your needs.

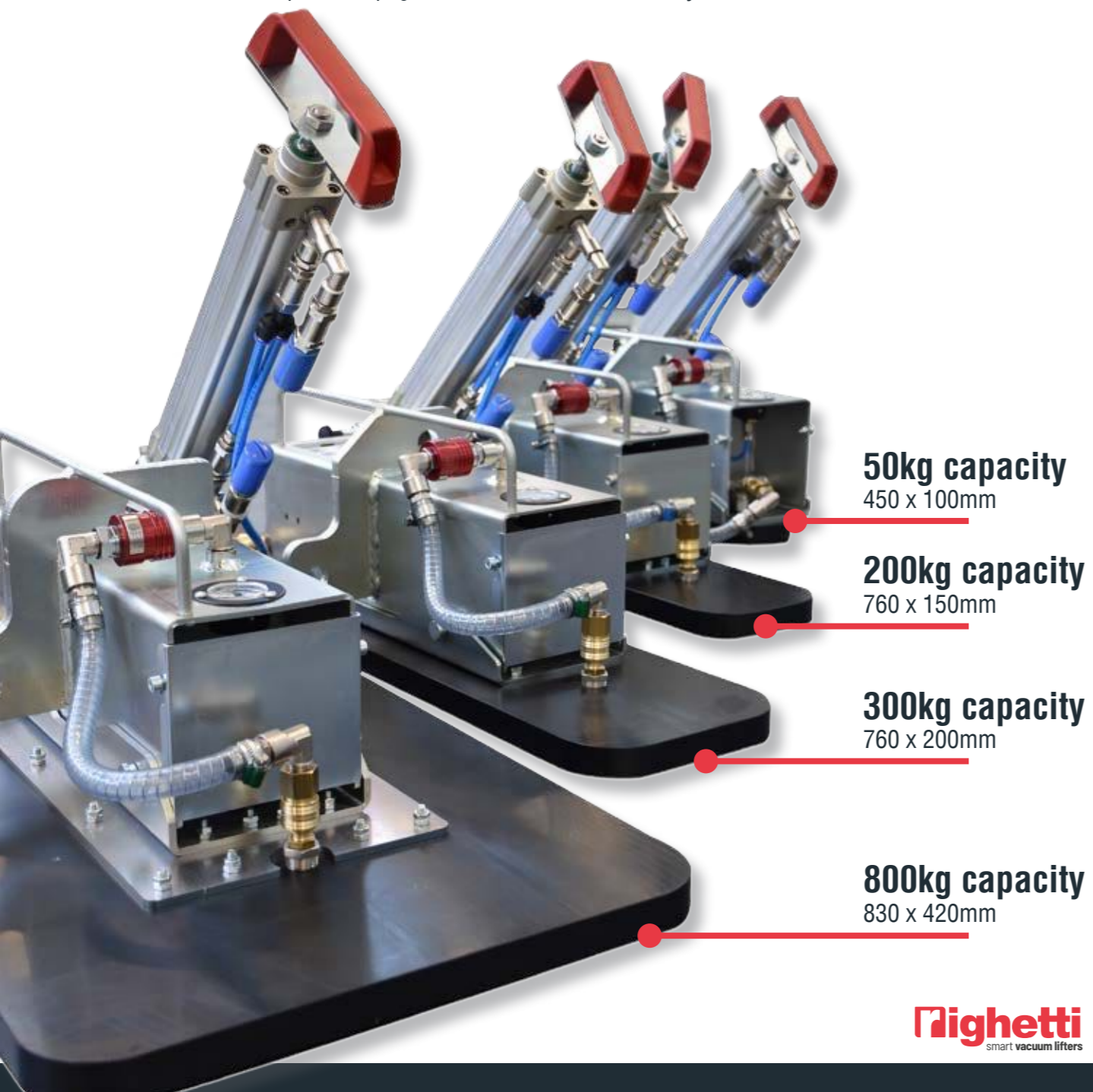

Dual grip handlebar

The dual grip handlebar is an useful optional that can be easily mounted on all S1 models. It allows the **manual lifting of the load by two people** for all those cases where the working site is not reachable with traditional lifting means.

Thanks to its maximum lifting capacity of **100 kg**, the dual grip handlebar makes stone installation easier, while **protecting the workers from potential health hazards** such as pinched fingers, fatigue and joint pains.



cod. S1-MAN

Beam for use with 2 or 3 suction pads

When **lifting and installing long, narrow paving slabs**, the beam with three suction pads is a useful ally. This accessory gets attached to the main body of the S1 series to provide stable and uniform support to the entire load thanks to its **length of 155cm**. The user can choose to use two or three suction pads.

The design of this optional aims to prevent the risk of damaging the material during its lifting, as it **ensures a balanced distribution of the load** and contributes to its precise and effortless laying.

cod. S1-TRAV



EDIL

Power supply
 Battery

Pads no.
1



Edil 160 is the ideal model for those environments where it is not possible to get with lifting means. Being battery powered, it features an economizer to guarantee a better duration of the battery level.

Edil 160 has an adjustable handle to be used by 2 or 4 operators and it allows to move the load without any crane or other lifting means.

Series Edil

 **160 kg**

Capacity Kg	Pads no.	Suction pads size (AxB) mm	Tare Kg	Model
160	1	350 x 230	21	EDIL160B

Technical drawings

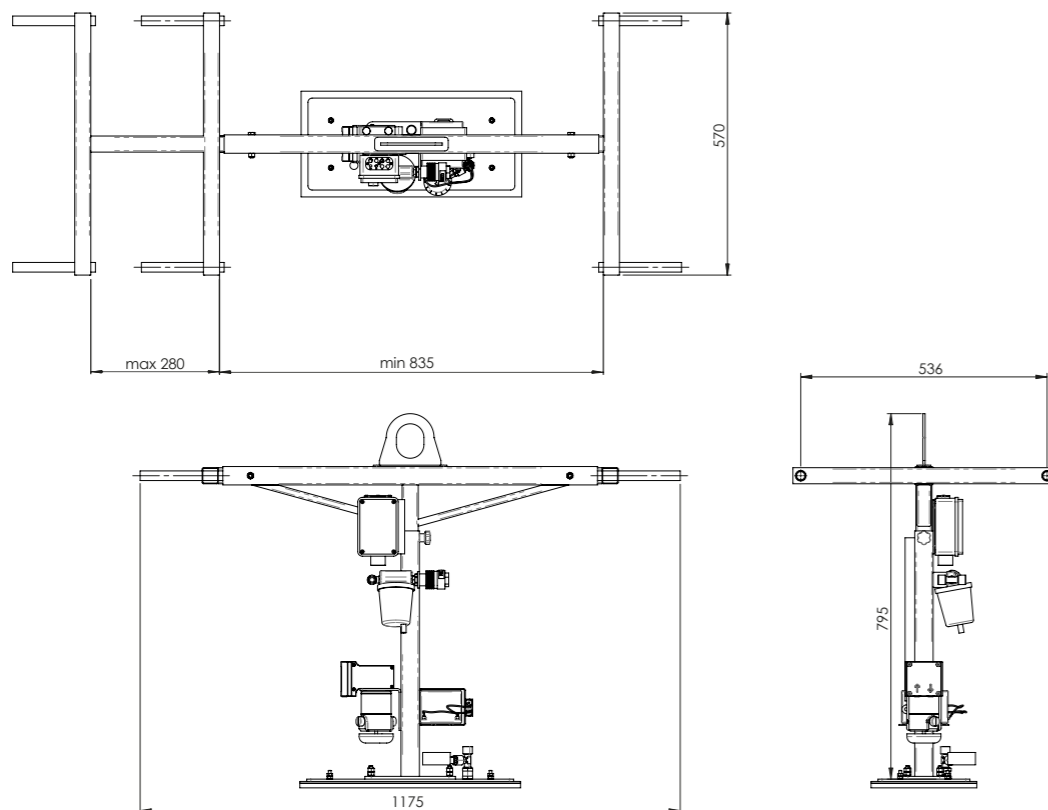

Stone vacuum lifters with a separate vacuum pump are an alternative to the standard vacuum lifters with an on-board vacuum pump

The vacuum lifter with separate vacuum pump is a frequent choice of stone workers, since it makes it possible to place the pump separately from the vacuum lifters (i.e. on overhead crane) protecting it from water and dust.

This solution is particularly useful and necessary for handling and lifting those materials which are porous, so it's necessary to compensate for the vacuum loss with a superior vacuum power.

Separate vacuum pumps are available with capacity from 4m³ to 100m³. The remote vacuum pumps are equipped with a vacuum reserve tank, a filter and a vacuum gauge.

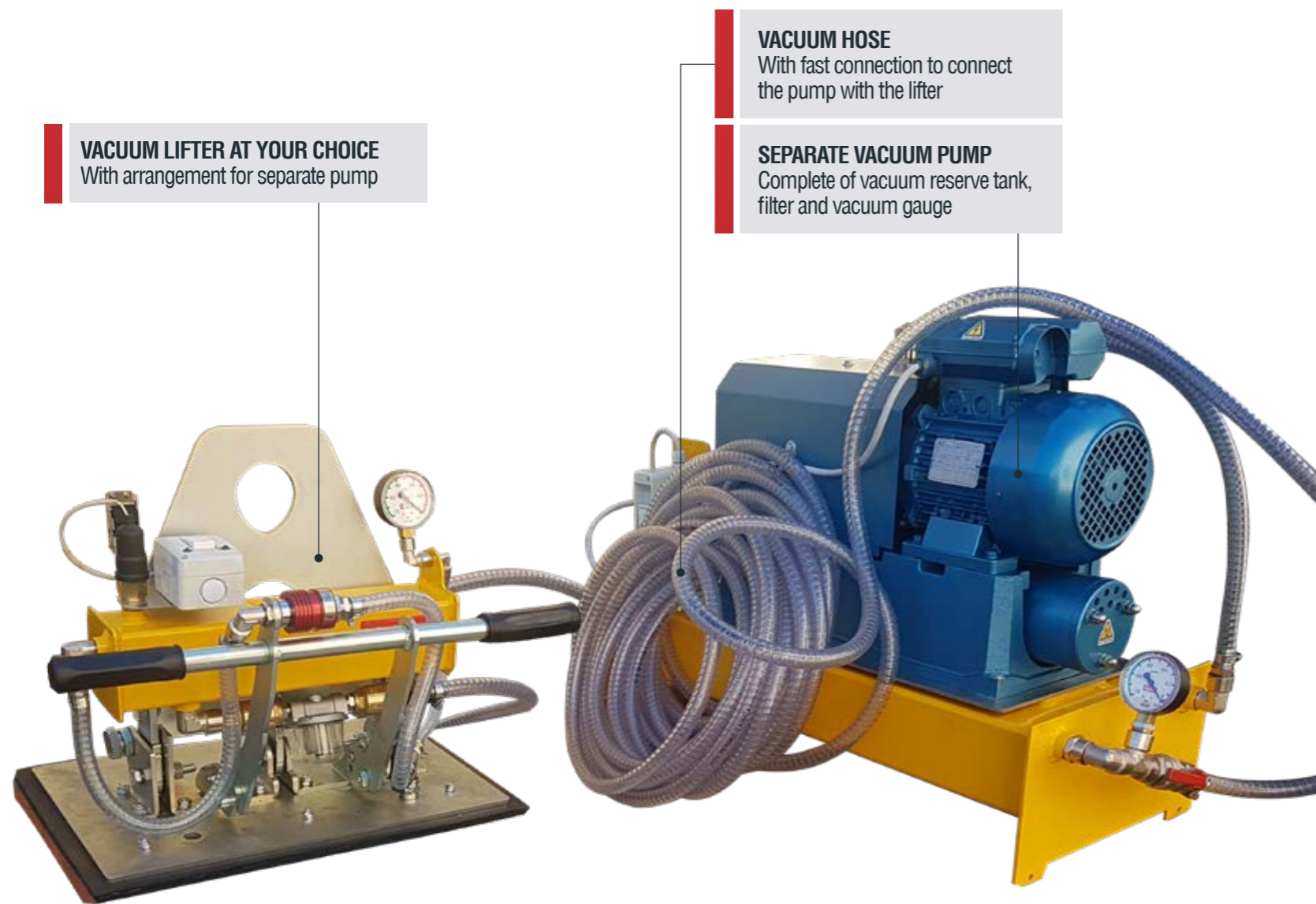

Stone vacuum lifters with separate vacuum pump

Customized solutions

Vacuum lifters specific for your lifting needs

This catalogue displays the majority of our standard models, developed during years by our expert team of designers and engineers.

However, in addition to the standard vacuum lifters production showed in this catalogue, there are also available vacuum lifters with:

- **different capacities**
- **custom made suction pads**
- **custom made frames and structures**
- **others various customizations**

To satisfy all needs, we have the experience and the skills to create the lifter you actually need, if our standard proposals don't meet the customer's necessities.

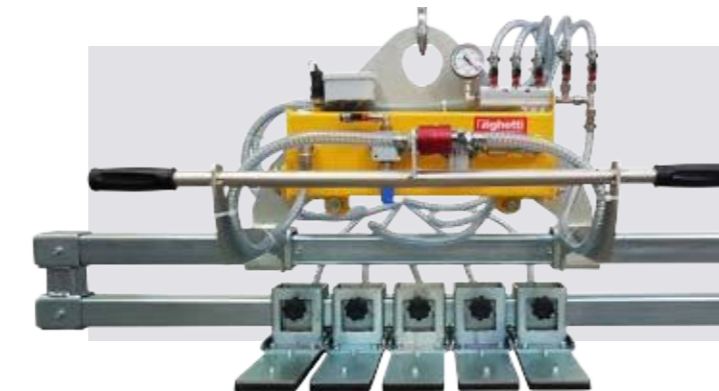
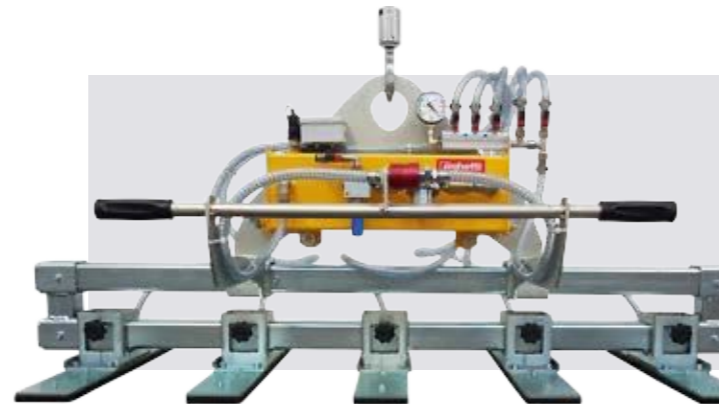

Optional

Parking Stand

As optional, different parking stands are available, even equipped with wheels for transport. They come in handy to store the lifter when not in use.



Interchangeable pads

To guarantee you a wide flexibility, some of our models have vacuum pads which are removable and interchangeable.



White gaskets

On request, white gaskets are available in substitution of the standard black ones.



Suction pads with fast rotation

Countertops vacuum lifters can be equipped with fast rotating suction pads to adapt to the different shapes of the slabs.



What you need to know

STANDARD CAPACITIES

Vacuum lifters' standard capacities go from 100kg to 2000kg. On request, there are available vacuum lifters with minor or major capacities.

If not differently specified, the maximum capacity stated is valid both for horizontal and vertical handling.

SUCTION PADS

Righetti suction pads feature gaskets specific for handling stone, being ideal for lifting slabs whose surface is:



Suction pads can be adjusted both in position along the centrale beam and in orientation (from longitudinal to transversal and viceversa).

Suction pads' shut-off is possible through practical taps, allowing individual use of the pads.

Handling porous stones?

Transpiring suction pads, such as natural travertine, require specific solutions with either majored or separated pump.

For understanding the porosity level of the stone and finding the best solution, we can run out suction tests.

Handling stones with irregular stones?

Lifting and handling of stones with irregular surfaces can represent a problem for workers.

To address these needs, we have designed gaskets specific for irregular surfaces: thanks to their special composition, they perfectly adapt to the surface of the stone to lift.



Technical information

Power supplies

Vacuum lifters are available with **several power supplies**:

COMPRESSED AIR Attachement to compressed air

Vacuum lifter is equipped with a vacuum pump (Venturi) which features a silencer and needs to be attached to the compressor. **Exercise pressure is 6bar.**

The standard vacuum pump has an **air consumption of 180nL/min.** This kind of pump guarantees a great aspiration speed even to the hardest materials thanks to its big capacity.

For energy saving, a vacuum pump with 90nL/min consumption is available as optional: this assures the perfect combination of energetic saving and performances.

For particular needs, we can offer you a vacuum pump with even **lower consumption (50nL/min)**, which is ideal for all those situations where you need to lower air consumption to minimum and you do not require optimal performances.

The **economizer** is an optional that manages the automatic switching on and off of the pump, providing the pump with compressed air flux only when necessary.

ON-BOARD AND SEPARATED ELECTRIC VACUUM PUMP

On "EB" series, the vacuum pump is placed on-board. You can choose between a 400V three-phases or 220V single-phase voltage. Other voltages are available on request.

BATTERIES

Battery-powered vacuum lifters are ideal for situations where it is hard to guarantee the connection to power supply. The vacuum lifters is **equipped with battery charger.**

Frame

Righetti vacuum lifters feature tilting system to handle stone slabs from horizontal to vertical position (and vice-versa).

Il movimento basculante può essere:

- **Manual 0-90°**
- **Powered by one or more pneumatic cylinders**
- **Powered by one or more hydraulic cylinders**

Safety

Maximum safety is guaranteed by several components.

Suction and release of the load is made through a **dual-action command valve**, which prevents from unwanted actions. The command can be executed on a manual valve placed on the frame of the vacuum lifter, via radio remote control or pushbutton.

The **vacuum gauge with coloured scale** helps the workers monitoring the vacuum in the circuit. Safety device intervention is regulated by a vacuum switch placed on the vacuum reservoir.

The latter **accelerates the suction of the load** and assures firm hold of the load in case of sudden power supply loss thanks to dual non-return valves.

Moreover, the vacuum lifter is equipped with **acoustic and visual alarms** which are autonomously powered: this device warns the operator about possible dangers.

On battery-powered models, the **vacuum control unit** monitors the vacuum level, checks the correct functioning of the components and controls the battery level.

This publication cancels and replaces previous editions. Images and product descriptions are indicative and not binding, as the products described are under constant development and subject to continuous updates. We reserve the right to make changes at any time and without prior notice. The information, illustrations and descriptions contained in the documentation do not give any entitlement to the modification of products already supplied.

Two extra services

To support you on the job.
Because you're always on our mind.



RIGHETTI SERVICE: Don't stop your job. Simple, fast, concrete assistance.

We also give continual assistance even remotely: we help you over the phone and/or in video calls, so that your job doesn't ever shut down. We stand by your side with rapid and precise assistance, provided directly by those who designed and built your lifter.

We'll also skilfully guide you in your selection of the accessories most suited to your needs to allow you to always work safely and be able to get the top tools.

If what you urgently need is a spare part, we guarantee record response time.

We do all this for you:

- over the phone assistance
- videoconference assistance
- direct contact with our team
- remote assistance for ordinary and extraordinary maintenance
- spare parts service

CUSTOMER CARE: what if you'll never be alone, wherever you are?

We know that during your job many questions can come up. Just like they can come up when choosing your lifter, or after having purchased it.

Your questions are important to us. Not only don't we want to miss them, but also we have created an ad hoc Customer Care. It will be available to answer any of your questions and needs, and you'll be able to get it anywhere: our website, social networks, by phone, or email. Wherever you are, we are there, too.





CLADDING



SHEET METAL



STONE



WOOD



GLASS



SPECIAL



CERAMIC

The only vacuum lifters
specialists for every application.
Especially yours.

Righetti
smart vacuum lifters



ITS

Righetti
smart vacuum lifters



SILCOM NORTH

www.silcomnorth.com hello@silcomnorth.com

Phone/Whatsapp +370 672216691 Goštauto 8, Vilnius 01108, Lithuania