

Vacuum glass lifter

CURVED GLASS KIT

The Righetti curved glass kit is a useful optional to easily transform a standard Righetti glass vacuum lifter into a curved glass vacuum lifter.

The kit can be mounted both on VB and GLE models.

The curved glass kit can feature 12, 16 or 20 suction pads, for a maximum lifting capacity of 600kg.

Example of GLE4+8 d4 transformed into a curved glass vacuum lifter:

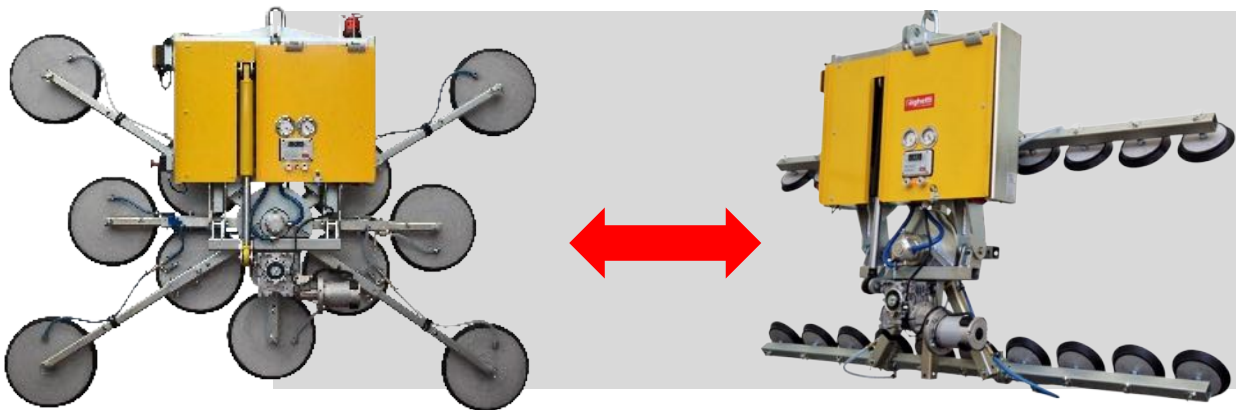

Example of VB4 RCMBM transformed into a curved glass vacuum lifter:

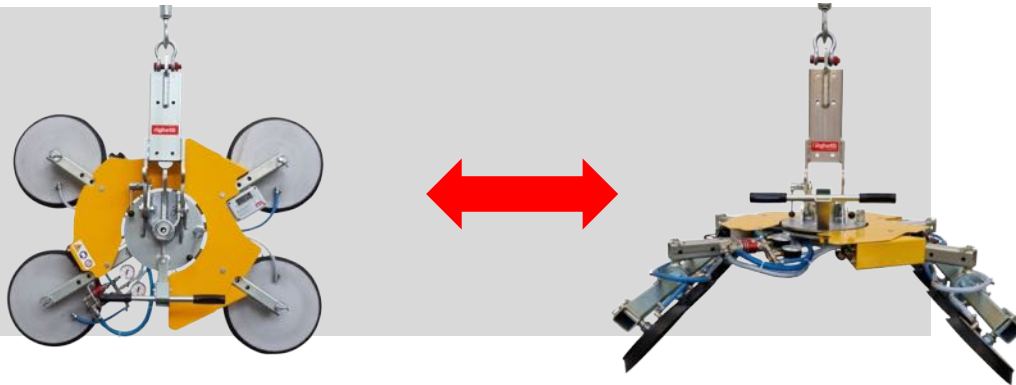

Available kits

Curved kit Code	Suction pads		Capacity Kg	Suction pads spread (mm)		
	No.	d. mm		X Min	X Max	Y
VB-KIT12C	12	200	400	507	1006	1325
VB-KIT16C	16	200	500	507	1006	1775
VB-KIT20C	20	200	600	507	1006	2225
VB-KIT12+8C	12	200	400	507	1006	1325
	20	200	600	507	1006	2225

Vacuum glass lifter

Capacity: max 400kg

Cod. VB-KIT12C

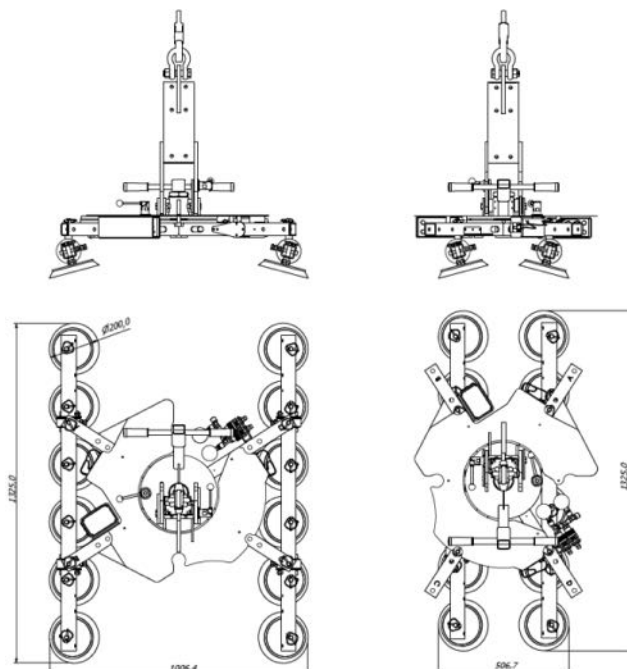
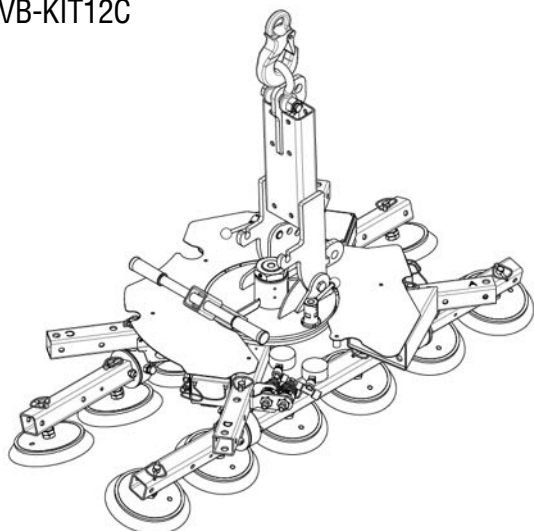

Capacity: max 500kg

Cod. VB-KIT16C

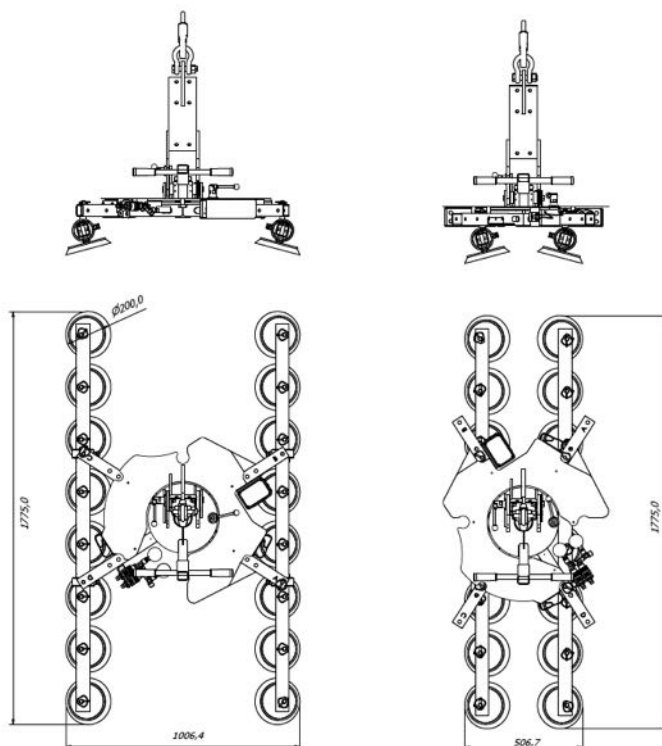
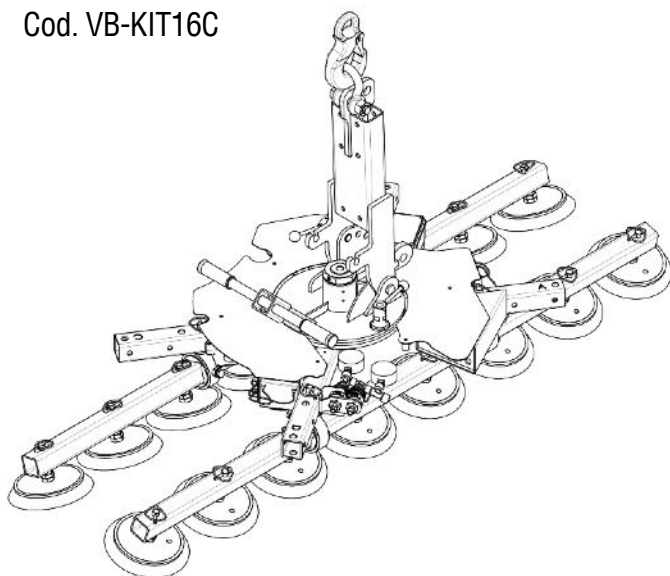

Vacuum glass lifter

Capacity: max 600kg

Cod. VB-KIT20C

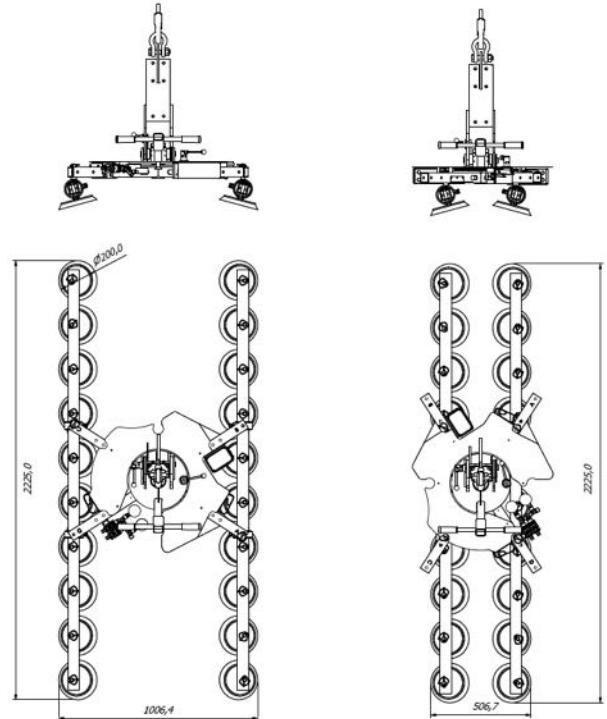
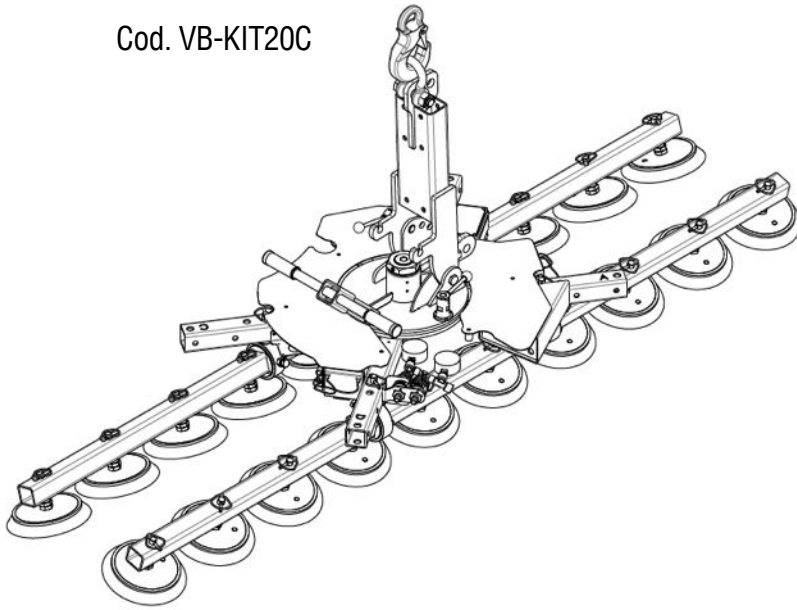

Cod. VB-KIT12+8C

TRANSFORMABLE

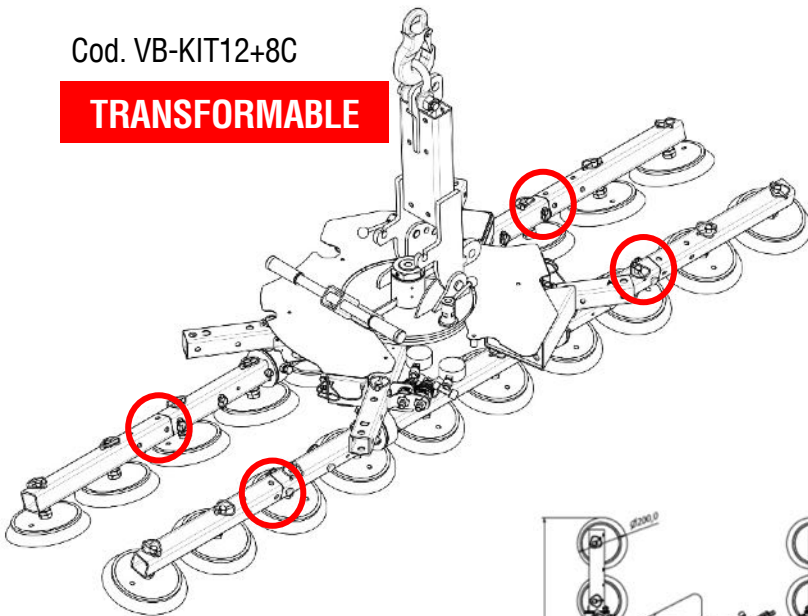

Connections for attaching
the 8 extra suction pads

