

## Series FS4A 250

 Kg max  
250

**AIR** Power supply  
Compressed Air

The Vacuum Lifter for sheets metal **FS4A 250** is a model with compressed air operating system and requires connection to the pneumatic system. The model FS4A 250 has a maximum capacity of 250 kg and **4 suction pads** distributed on 2 cross-arms. The pads, equipped with springs, are made of **special oil-resistant vulcanized rubber**, specific for sheet metal.

Adjusting the position of the pads and arms allows you to **adapt the vacuum lifter to the different sizes and shapes** of the sheets metal. The FS4A 500 model has a **steel reinforced supporting structure** and a horizontal fixed frame.

A special feature of the FS4 model is its **lowered structure** which significantly **reduces the height below the hook**. The Vacuum Lifter FS4 is particularly suitable for **loading sheet metal on laser cutting**.



Horizontal lifting



4 suction pads d.200 mm



Safety devices



Capacity 250Kg



Lowered structure

Available also with  
6 pads – capacity 500kg

For standard sizes:

3 x 1,5 m 4 x 2 m 6 x 2,5 m 

### Technical specification

<b>Application</b>	Metal sheet, stainless steel, aluminium, plastic panels
<b>Lifting capacity</b>	250 kg
<b>Suction pads</b>	Nr.4 suction pads in vulcanized rubber, diameter 200 mm Suction pads with spring supports Exclusion of suction pads by cross arm
<b>Frame</b>	Steel frame structure fixed in horizontal position Lowered below the hook high The suction pads are distributed on cross arms Adjustable position of suction pads and of cross arms
<b>Operating system</b>	Compressed air
<b>Vacuum system</b>	Vacuum circuit with vacuum reservoir, non-return valve, vacuum filter
<b>Safety systems</b>	Vacuum gauge with colored scale Audio visual low vacuum warning powered independently and with back up battery
<b>Weight of lifter</b>	52 Kg
<b>Command</b>	Suction and release by slide valve command with safety system



Technical drawing

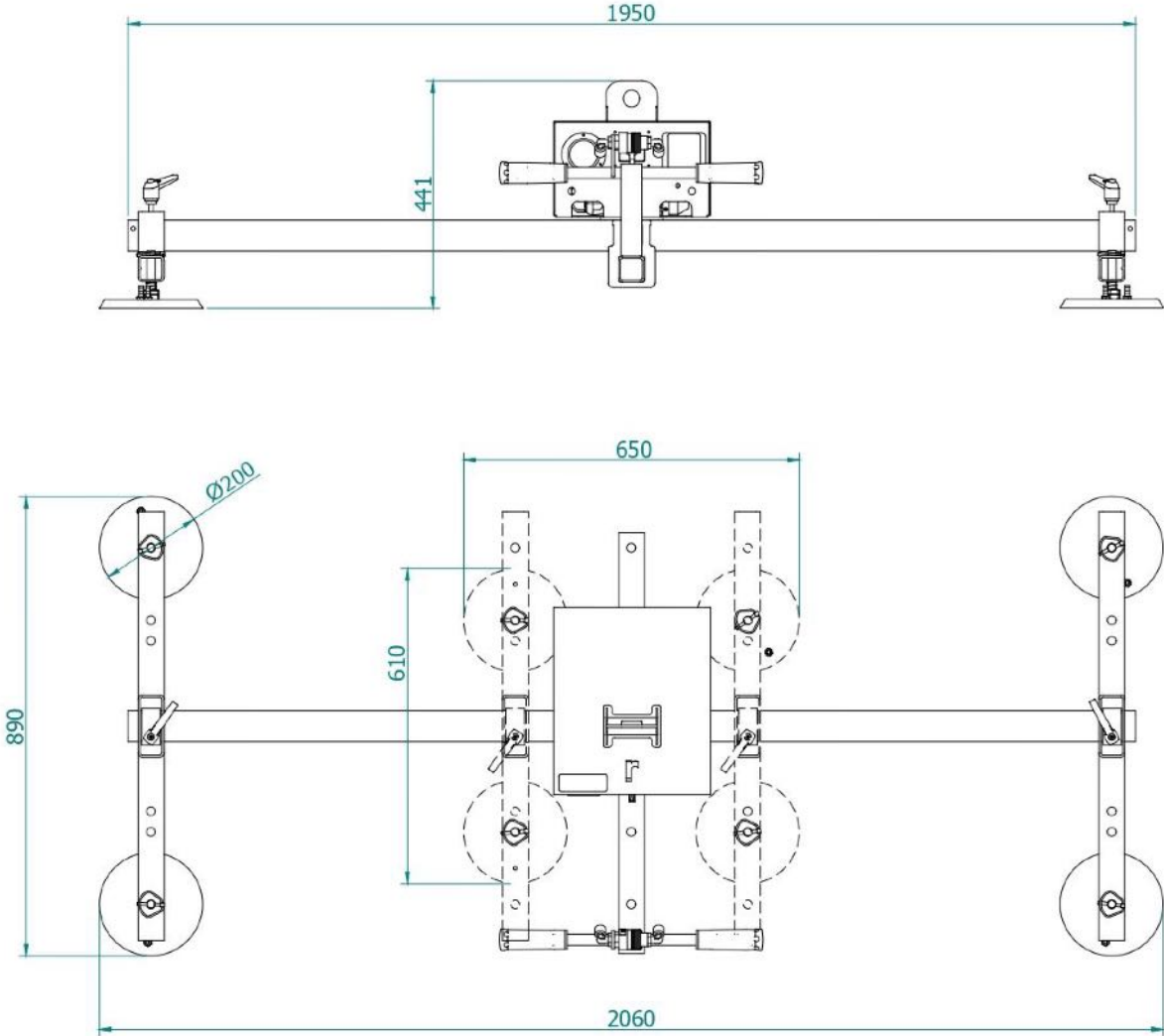

**Series FS4A 250**

 **Kg max 250**

Pads		Capacity	L	Arms		X (mm)		Y (mm)		Product code
nr.	Ø	kg	mm	nr.	mm	min	max	min	max	
4	200	250	1950	2	830	650	2060	610	890	<b>FS4A 250</b>