

Series FS6A 500

 Kg max
500

AIR Power supply
Compressed Air

The Vacuum Lifter for sheets metal **FS6A 500** is a model with compressed air operating system and requires connection to the pneumatic system. The model FS6A 500 has a maximum capacity of 500 kg and **6 suction pads** distributed on 3 cross-arms. The pads, equipped with springs, are made of **special oil-resistant vulcanized rubber**, specific for sheet metal.

Adjusting the position of the pads and arms allows you to **adapt the vacuum lifter to the different sizes and shapes** of the sheets metal. The F6SA 500 model has a **steel reinforced supporting structure** and a horizontal fixed frame.

A special feature of the FS6 model is its **lowered structure** which significantly **reduces the height below the hook**. The Vacuum Lifter FS6 is particularly suitable for **loading sheet metal on laser cutting**.



Horizontal lifting



6 suction pads d.200 mm



Safety devices



Capacity 500Kg



Lowered structure

Available also with
4 pads – capacity 250kg

For standard sizes:

3 x 1,5 m 4 x 2 m 6 x 2,5 m

Technical specification

Application	Metal sheet, stainless steel, aluminium, plastic panels
Lifting capacity	500 kg
Suction pads	Nr. 6 suction pads in vulcanized rubber, diameter 200 mm Suction pads with spring supports Exclusion of suction pads by cross arm
Frame	Steel frame structure fixed in horizontal position Lowered below the hook high The suction pads are distributed on cross arms Adjustable position of suction pads and of cross arms
Operating system	Compressed air
Vacuum system	Vacuum circuit with vacuum reservoir, non-return valve, vacuum filter
Safety systems	Vacuum gauge with colored scale Audio visual low vacuum warning powered independently and with back up battery
Weight of lifter	55 Kg
Command	Suction and release by slide valve command with safety system



Technical drawing

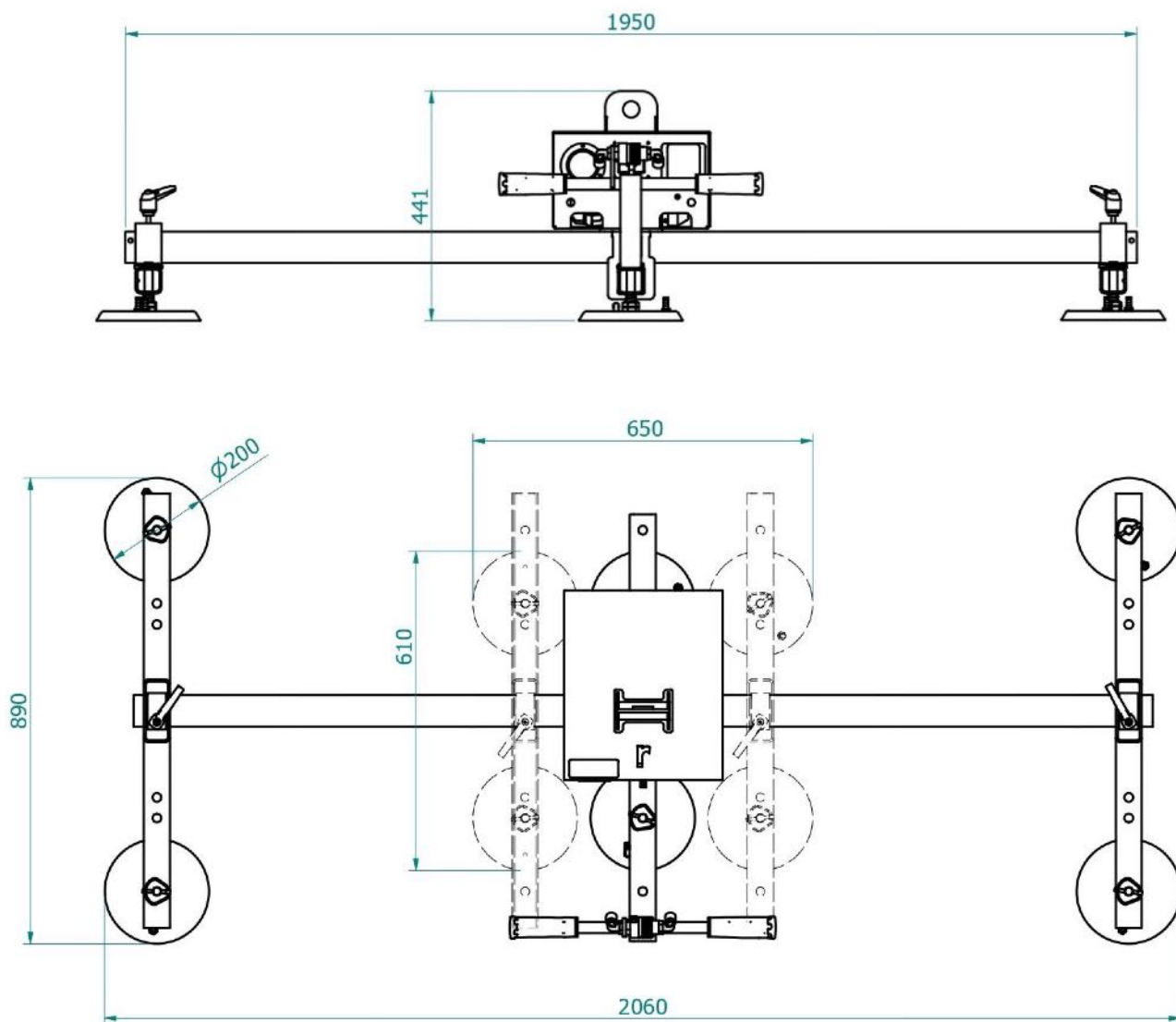

Series FS6A 500

 **Kg max 500**

Pads		Capacity	L	Arms		X (mm)		Y (mm)		Product code
nr.	Ø	kg	mm	nr.	mm	min	max	min	max	
6	200	500	1950	3	830	650	2060	610	890	FS6A 500