

## Vacuum lifter

# Righetti

Vacuum lifters  
SPECIALISTS

smart vacuum lifters

## Model FS6B 500



Kg max  
500



Power supply  
Batteries



The sheet metal vacuum lifter FS6B is battery powered by high capacity rechargeable batteries (battery charger is included). FS6B has a maximum capacity of 500 kg and **6 suction pads** distributed on 3 cross-arms. The pads, equipped with springs, are made of **special oil-resistant vulcanized rubber**, specific for sheet metal.

A special feature of the FS6 model is its lowered structure which significantly reduces the height below the hook. Adjusting the position of the pads and arms allows you to **adapt the vacuum lifter to the different sizes and shapes** of the sheets metal. The FS6B 500 model has a **steel reinforced supporting structure** and a horizontal fixed frame.



Horizontal lifting



6 suction pads d. 200 mm



Safety devices



Capacity 500Kg



Lowered structure

Available also with  
capacity 250kg

For standard sizes:

3 x 1,5 m 4 x 2 m 6 x 2,5 m 

### Technical specification

<b>Application</b>	Metal sheet, stainless steel, aluminium, plastic panels
<b>Lifting capacity</b>	500 kg
<b>Suction pads</b>	Nr. 6 vacuum pads d. 200 mm
<b>Frame</b>	Steel frame structure fixed in horizontal position The suction pads are distributed on 3 cross arms Adjustable position of suction pads and of cross arms
<b>Operating system</b>	Battery operating system DC vacuum pump powered from on-board batteries High capacity re-chargeable batteries, battery status indicator Economizer for reduction of the energy consumption
<b>Vacuum system</b>	Vacuum circuit with vacuum reservoir, non-return valve, vacuum filter
<b>Safety systems</b>	Vacuum gauge with colored scale Audio visual low vacuum warning powered independently and with back up battery
<b>Weight of lifter</b>	Kg 59
<b>Command</b>	Suction and release by slide valve command with safety system
<b>Optional</b>	Radio remote control (for suction and release at a distance)

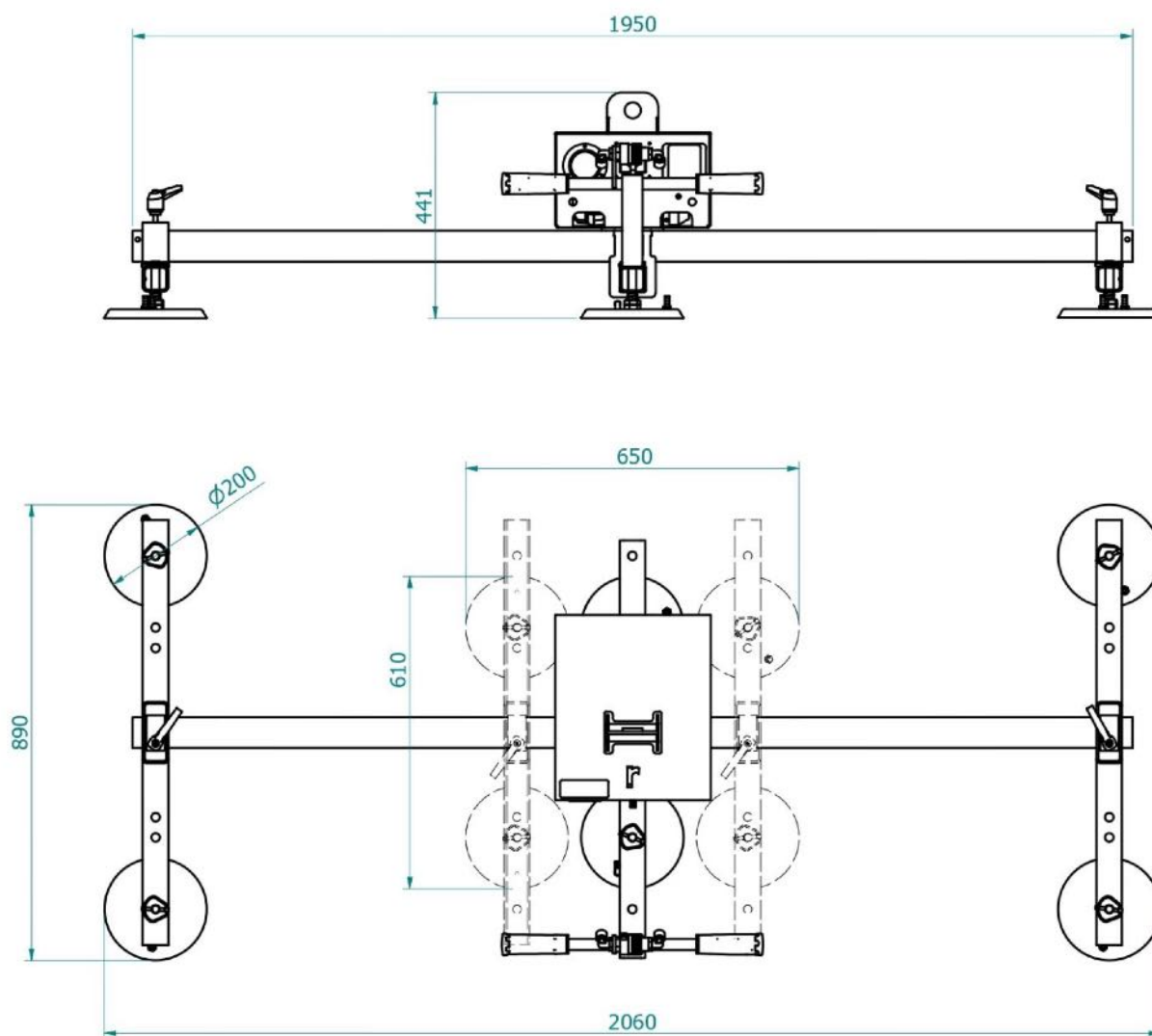
**Technical drawing**

**Model FS6B**
 **Kg max 500**

Pads		Capacity	Crossbeam	Arms		X (mm)		Y (mm)		Product code
nr.	Ø	kg	mm	nr.	mm	min	max	min	max	
6	200	500	1950	3	830	650	2060	610	890	FS6B 500