

Vacuum lifter



Model

FTS6A 1000

 Kg max
1000

AIR Power supply
Compressed Air

Telescopic handle

The Vacuum Lifter for sheet metal FTS6A 1000 is a model with compressed air operating system and requires connection to the pneumatic system. **The lifter FTS6A 1000 is a model with telescopic structure**, adjustable in several positions.

The advantage of the telescopic Vacuum Lifter for sheets metal is to be able to lift, with a single tool, different formats of material as the structure can be **easily and quickly adapted from the largest to the smallest sheets**.

The telescopic Vacuum Lifter is particularly suitable for serving laser cutting stations that need a professional and durable tool.

Thanks to its **lowered structure** it is possible to use the Vacuum Lifter to lift the sheets even in contexts where it is necessary to reduce the height under the hook, due to not particularly high ceilings or various impediments in height.

In addition to having a telescopic structure with width adjustment, the FTS6 metal sheet lifter also has a comfortable **telescopic handlebar** to control the lifter and maintain the correct safety distance from the load. The feature that distinguishes the FTS6 model is its sturdy and solid structure, specifically designed for professional and continuous use.



Horizontal lifting



6 suction pads d.310 mm



Safety devices



Capacity 1000Kg



Telescopic structure

Available also with
capacity 1800kg

For standard sizes:

3 x 1,5 m 4 x 2 m 6 x 2,5 m 

Technical drawing

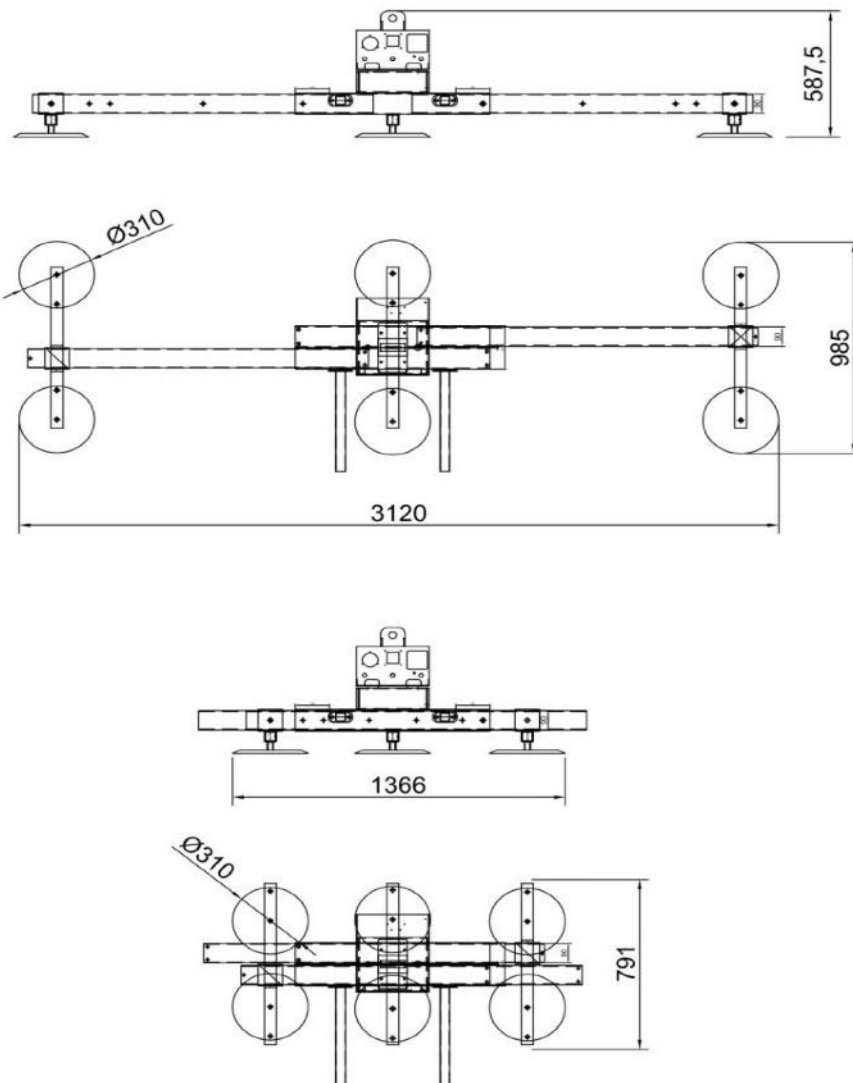

Technical specification

Application	Metal sheet, stainless steel, aluminium, plastic panels
Lifting capacity	1000 kg
Suction pads	Nr. 6 suction pads in vulcanized rubber, diameter 310 mm Suction pads with spring supports Exclusion of suction pads by cross arm
Frame	Telescopic steel frame structure fixed in horizontal position Adjustable position of suction pads and arms
Operating system	Compressed air
Vacuum system	Vacuum circuit with vacuum reservoir, non-return valve, vacuum filter
Safety systems	Vacuum gauge with colored scale Audio visual low vacuum warning powered independently and with back up battery
Weight of lifter	120kg
Command	Suction and release by slide valve command with safety system