

Righetti

smart vacuum lifters

Model

GL-VB4TR

Vacuum glass lifter

 Kg max
400

 Power supply
Batteries



GL-VB4 vacuum glass lifter is a modular vacuum lifter. Along the 1500mm long central beam, the **4 suction pads** are repositionable on the arms, which are movable as well along the central beam.

It is powered by **rechargeable batteries** that, if necessary, can be quickly removed for external recharge (battery charger included).

The GL-VB4 vacuum lifter features **manual 90° tilt and manual 360° rotation**. Its compact and flat design, allows GL-VB4 to work also behind scaffoldings. Equipped with a dual vacuum circuit, smart control unit and safety systems, GL-VB4TR is **ideal for construction site use**.



Manual tilt 0-90°



Capacity max 400kg



Manual continuous rotation 360°



Safety devices



4 vacuum pads d.310 mm



Dual vacuum circuit built to
EN13155 standard

CE

made in
ITALY

Technical drawings

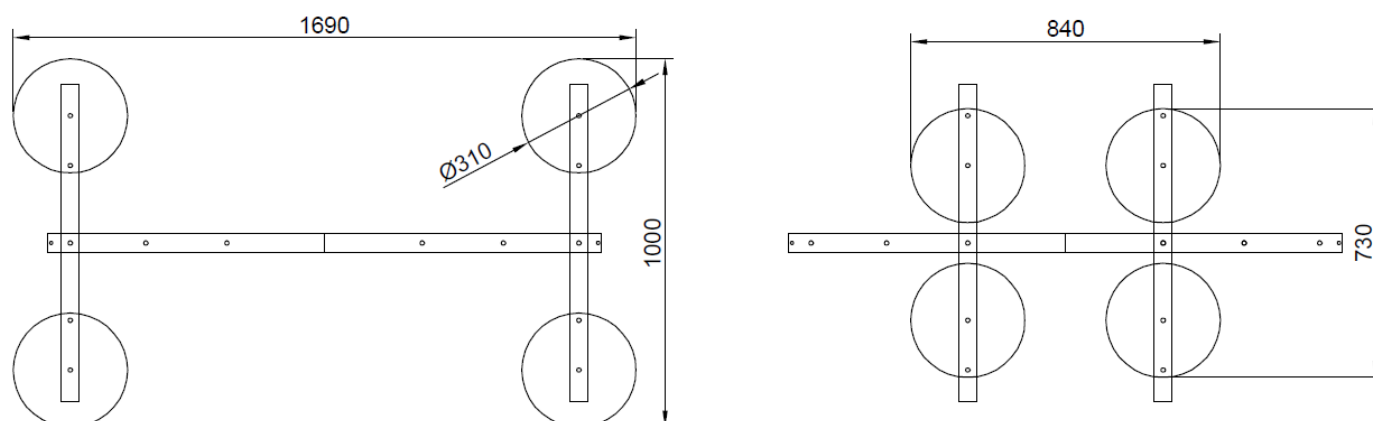

Technical specification

| | |
|--------------------------|---|
| Application | Glass panels |
| Lifting capacity | Max 400 kg |
| Suction pads | No. 4 round suction pads diameter 310 mm Lipped pads with safety ring |
| Pad spread | Repositionable pads and arms Cross configuration: 1690x1000 (max pad spread) / 840x730 (min pad spread) |
| Load movement | Continuous 360 degree rotation, with possibility of automatic locking at each 90° 90 degree tilt, with possibility of automatic locking in upright and flat position |
| Operating system | DC vacuum pump powered from on-board batteries High capacity rechargeable batteries; Battery status indicator Economizer for reduction of the energy consumption |
| Vacuum system | 2 independent vacuum circuits, each vacuum circuit with vacuum reserve and non return valve |
| Weight of lifter | Kg 81 |
| Structural depth | mm 250 |
| Control | Manual on-off valve on the lifter's frame Release of the load by dual action security command |
| Standard features | Audible and visual low vacuum warning devices Vacuum gauge for each vacuum circuit Battery charger 240 Volt |