

Vacuum glass lifter

Model

GLE4+8 d4

 Kg max
1500

 Power supply
Batteries

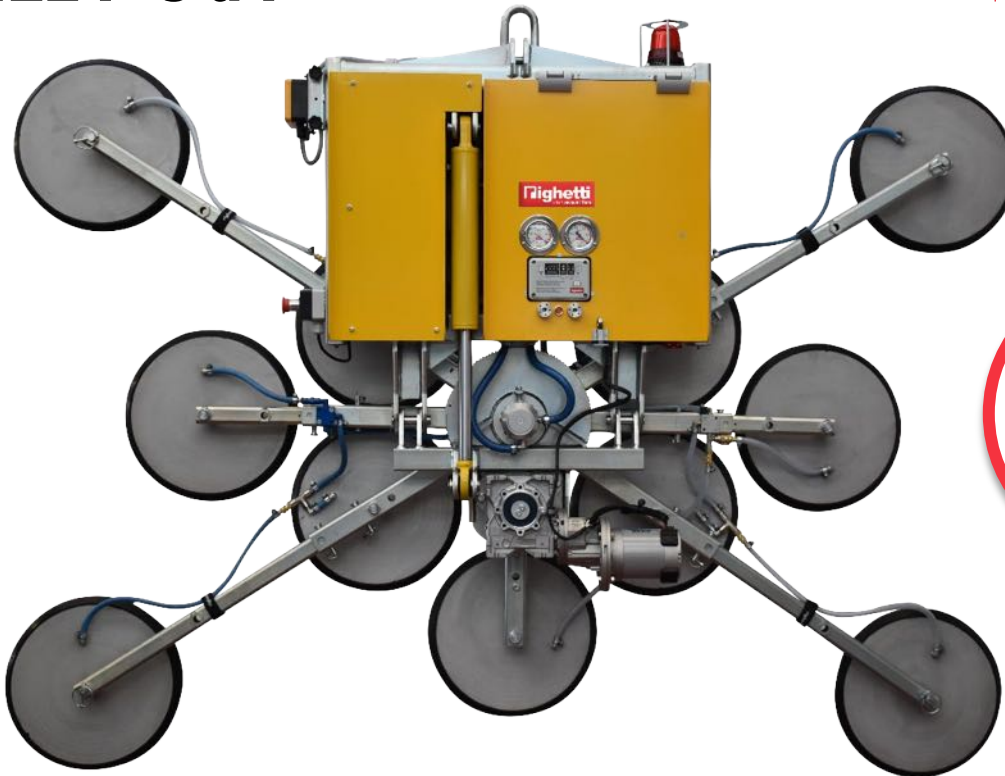

Vacuum glass lifter series GLE4+8 has a battery operating system with rechargeable batteries that, if necessary, may be easily removed and quickly replaced.

Vacuum lifter GLE has **compact and slim frame**, only 310 mm width. The lifter offers **hydraulic tilting system and electric 360° continues rotation**. Professional, quality components and strong lifter's frame guarantee safety and reliable lifting and handling also of the big glass elements. GLE4+8 has 12 suction pads, 4 on lifter's body and 8 on removable extensions. The **extensions allow to modify the lifter's configuration** and lifting capacity adapting the lifter for different glass dimensions. The pad arms may be removed quickly and easily.

Suction, release, rotation and tilting movements are controlled at distance by **wireless radio remote control**. As optional, an additional siren alarm is available.



Powered tilt 0-90°



Powered rotation 360°



Modular frame



Dual vacuum circuit
in compliance with EN13155



Safety devices



Vacuum glass lifter

Technical specification

Application	Glass panels
Lifting capacity	Max 1500 kg – the lifting capacity depends on the configuration
Suction pads	No. 4 + 8 round suction pads - diameter 390 mm Lipped pads with safety ring
Pad spread	Pads are movable in different configurations 4 pads mm 1020 x 800 12 pads mm 2250 x 1600
Load movement	Powered 360-degree electric rotation Powered 90-degree hydraulic tilting system
Operating system	DC vacuum pump powered from on-board batteries High-capacity re-chargeable batteries Battery status indicator Economizer for reduction of the energy consumption
Vacuum system	2 independent vacuum circuits, each vacuum circuit with vacuum reserve and non return valve
Weight of lifter	Kg 242
Structural depth	mm 310
Control	Tilting, rotation, suction and release are controlled by wireless radio remote control Release of the load by dual action security command
Standard features	Audible and visual low vacuum warning devices Vacuum gauge for each vacuum circuit; vacuum filter Battery charger 240 Volt Multi position hook connection

Technical drawings

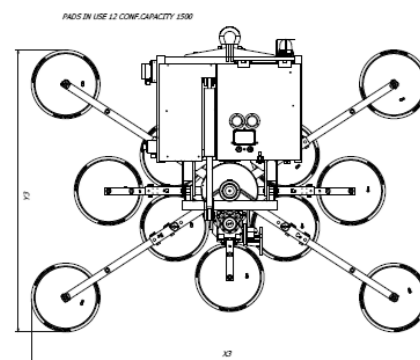
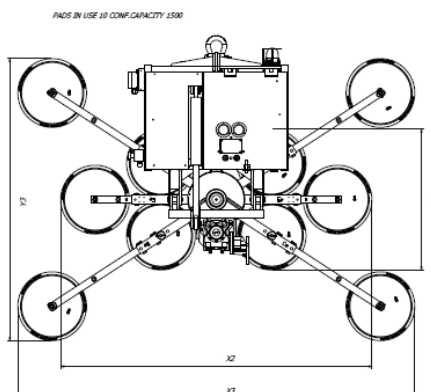
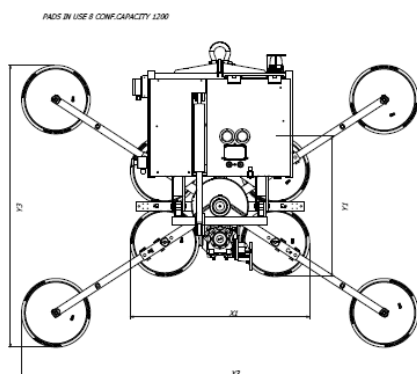
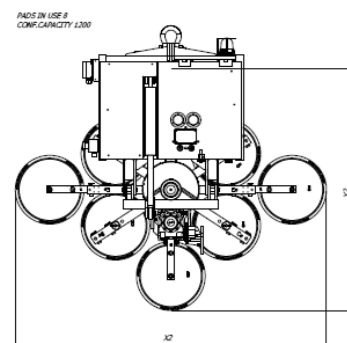
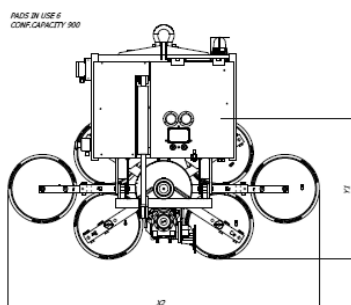
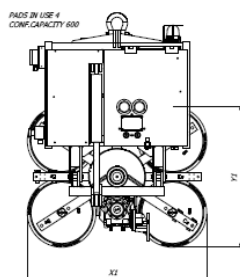

Vacuum glass lifter

GLE 4+8 d4 1500kg

 **Kg max 1500**

Suction pads		Capacity	Product code	Configurations			Suction pads spread
No.	Ø mm	Kg		Pads in use	Conf. capacity	Dimensions	mm
12	390	1500	GLE 4+8 d4	4	600	X1 * Y1	1020 X 800
				6	900	X2 * Y1	1765 x 800
				8	1200	X2 * Y2	1765 x 1370
				8	1200	X3 * Y3	2250 x 1600
				10	1500	X3 * Y3	2250 x 1600
				12	1500	X3 * Y3	2250 x 1600

Use examples in different configurations

