

Vacuum lifter



Series M1B



The M1B is a series of Vacuum Lifters which contains a wide range of one plate models with capacities ranging from **100 kg to 1000 kg**. The **M1B series is powered by** on board, rechargeable and long lasting **battery**. The battery charger is included. The **manual tilting system** allows a vertical – horizontal movement and vice versa. The maximum capacity of the lift depends on the size of the suction plates.

It is equipped with an **audio-visual alarm** control unit that warns the operator of possible dangerous situations. The vacuum gauge with coloured scale allows constant control of the vacuum level reached. It is present a **filtering system** for dust and condensation.

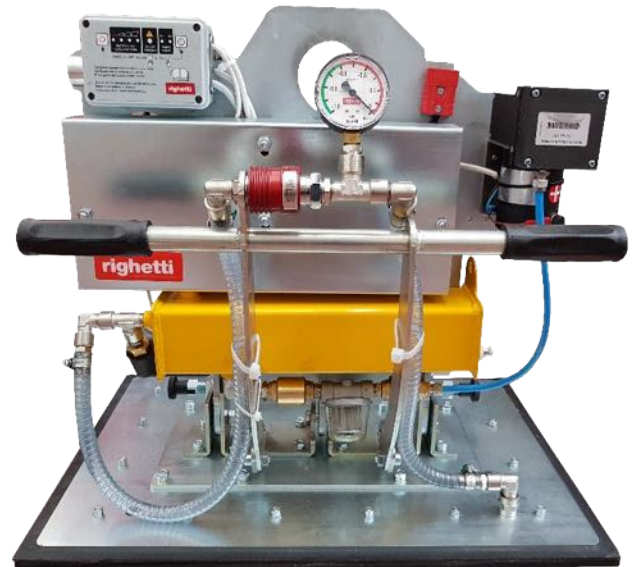

Horizontal lifting



Vertical lifting



Manual tilt 0-90°

✓ 1 suction pad

✓ Max capacity 1000 kg

✓ Safety devices



Technical specification

Application	Not porous materials
Lifting capacity	Models up to 1000 kg
Suction pads	Nr. 1 suction pad
Load movement	Manual tilt 0-90°
Operating system	Batteries
Vacuum system	Vacuum circuit, complete of vacuum reserve and non return valve
Control	Manual valve on the lifter's frame Release of the load by dual action security command
Standard features	On-off double sliding valve with safety Audible and visual low vacuum warning devices Vacuum gauge with coloured scale, vacuum filter, non return valves
Optional	White gaskets Holder for hoist command

Technical drawing

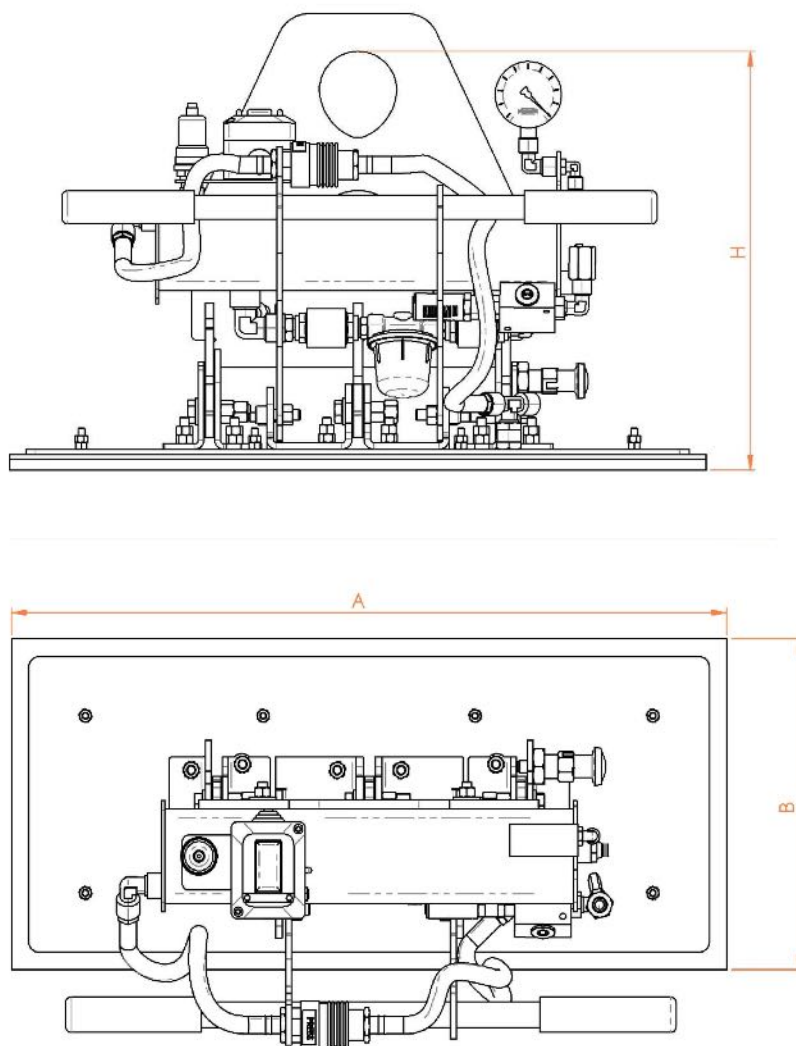

Series M1B

 **Kg max 1000**

Product code	Lifting capacity kg	A mm	B mm	H mm
M1B 125	125	480	230	380
M1B 200	200	730	190	380
M1B 250	250	630	280	380
M1B 300	300	630	330	380
M1B 500	500	630	430	380
M1B 750	750	830	480	450
M1B 1000	1000	960	530	450