

## Vacuum lifter



### SerieS M1EB

The Vacuum Lifter M1EB series includes a **wide range of single plate models** with capacity ranging from 100 kg to 1000 kg.

The M1EB series is powered by electricity, it can be 400V 3phases or 220V 1phase.  
The **manual tilting system** allows a vertical – horizontal movement and vice versa.

The maximum capacity of the lifter depends on the size of the suction plate.

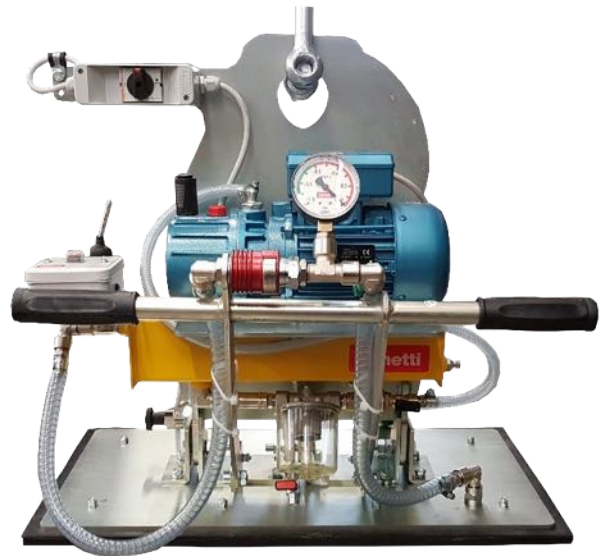

Horizontal lifting

✓ 1 suction pad



Vertical lifting

✓ Max capacity 1000 kg



Manual tilt 0-90°

✓ Safety devices

CE

made in  
ITALY

### Technical specification

<b>Application</b>	Not porous materials
<b>Lifting capacity</b>	Models up to 1000 kg
<b>Suction pads</b>	Nr. 1 suction pad
<b>Load movement</b>	Manual tilt 0-90°
<b>Operating system</b>	Electric vacuum pump 220V 1 ph or 400 3ph - 50Hz
<b>Vacuum system</b>	Vacuum circuit, complete of vacuum reserve and non return valve
<b>Control</b>	Manual valve on the lifter's frame Release of the load by dual action security command
<b>Standard features</b>	On-off double sliding valve with safety Audible and visual low vacuum warning devices Vacuum gauge with colored scale, vacuum filter, non return valves
<b>Optional</b>	White gaskets Holder for hoist command

## Technical drawing

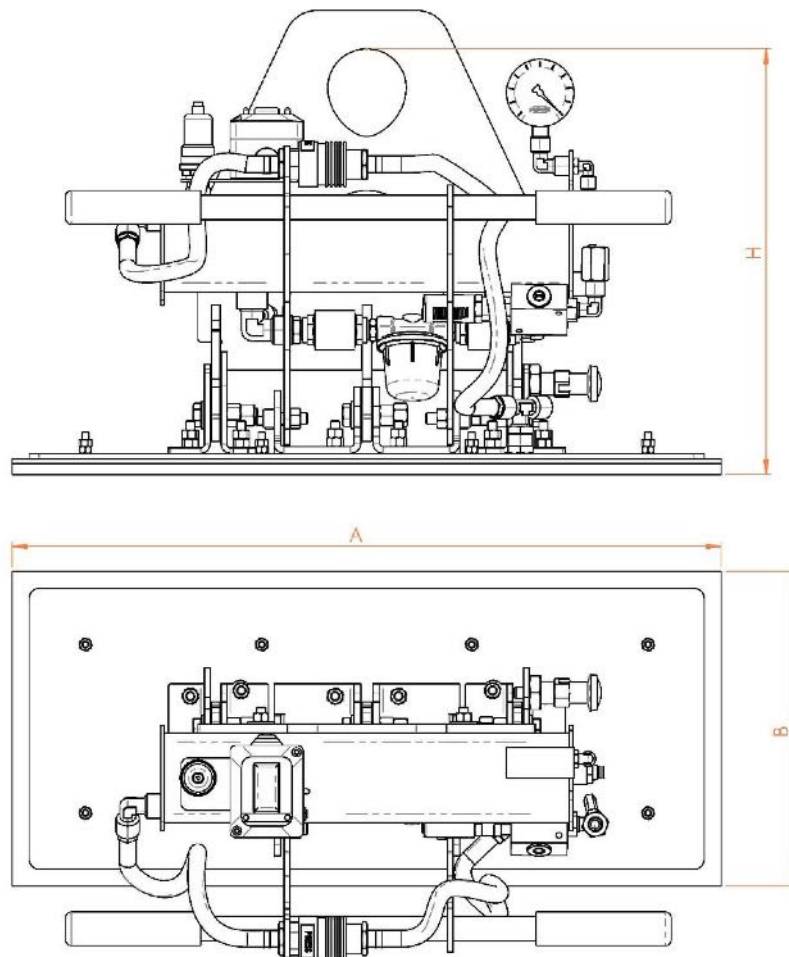

## Series M1EB

 **Kg max 1000**

Product code	Lifting capacity Kg	A mm	B mm	H mm
M1EB 125	125	480	230	550
M1EB 200	200	730	190	550
M1EB 250	250	630	280	550
M1AEB 300	300	630	330	550
M1EB 500	500	630	430	550
M1EB 750	750	630	480	640
M1EB 1000	1000	960	530	640