

Righetti

Vacuum lifters
SPECIALISTS

Series
M2EB

smart vacuum lifters

Vacuum lifter



The M2EB is a series of Vacuum Lifters which contains a wide range of 2-plates models with **capacities ranging from 250 kg to 1500 kg**. The M2EB series is electric powered and it can be produced with voltage 220V 1phase or 400V 3phases.

The **manual tilting** system allows a vertical – horizontal movement and vice versa. The maximum capacity of the lift depends on the size of the suction plates.

Equipped with an **audio-visual alarm control** unit that warns the operator of possible dangerous situations. The vacuum gauge with coloured scale allows constant control of the vacuum level reached. Present a **filtering system** for dust and condensation.



Horizontal lifting

✓ 2 suction pads



Vertical lifting

✓ Max capacity 1500 kg



Manual tilt 0-90°

✓ Safety devices

CE

made in
ITALY

Technical specification

Application	Not porous materials
Lifting capacity	Models up to 1500 kg
Suction pads	Nr. 2 suction pads
Load movement	Manual tilt 0-90°
Operating system	Electric vacuum pump 220V 1 ph or 400 3ph - 50Hz
Vacuum system	Vacuum circuit, complete of vacuum reserve and non return valve
Control	Manual valve on the lifter's frame Release of the load by dual action security command
Standard features	On-off double sliding valve with safety Audible and visual low vacuum warning devices Vacuum gauge with colored scale, vacuum filter, non return valves
Optional	White gaskets Holder for hoist command

Technical drawing

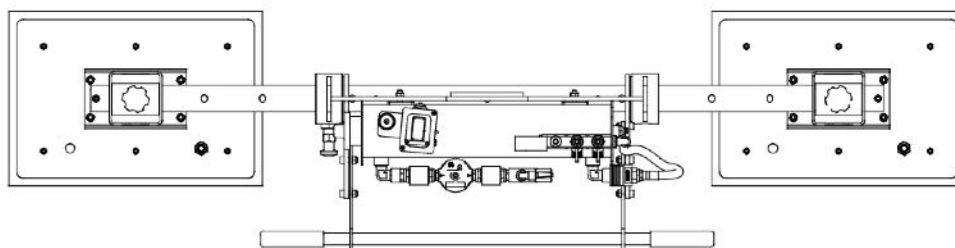
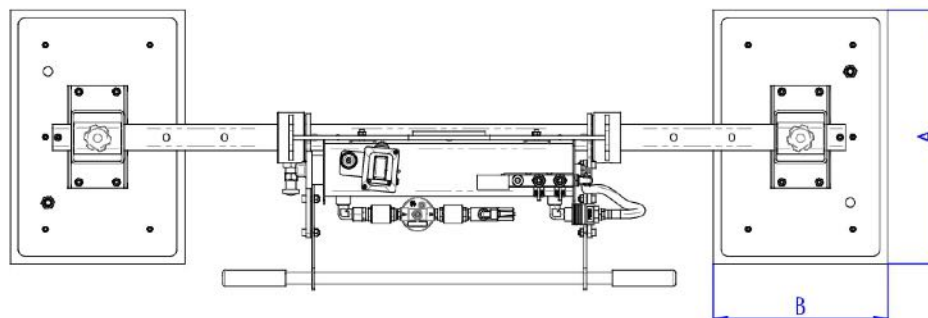
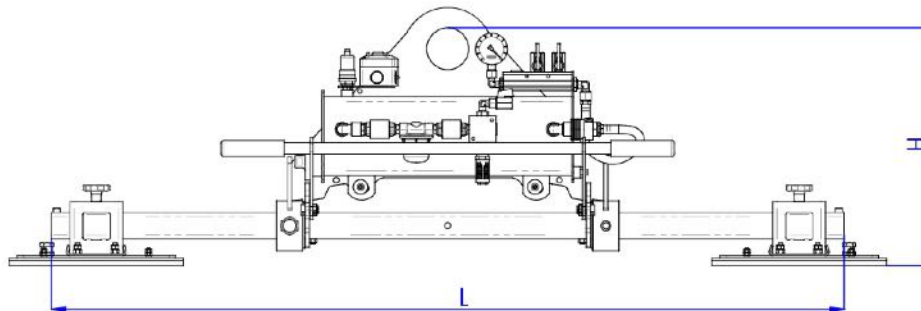

Series M2EB

 **Kg max 1500**

Product code	Lifting capacity	A	B	H
M2EB 250	250	480	230	650
M2EB 500	500	480	330	650
M2EB 1000	1000	630	430	650
M2EB 1500	1500	830	480	650

*L = 1500mm. On request different lengths of the cross-beam.