

Series

M4A-K

Kitchen top vacuum lifter



AIR Power supply
Compressed Air



The M4A-K series is a range of vacuum lifters **specific for kitchen tops** with lifting capacity up to 440 kg. This lifter is powered by compressed air. The **manual tilting system** allows an assisted movement of the load from vertical to horizontal and vice versa. Equipped with an on-off sliding valve against the involuntary release of the load. The vacuum gauge with coloured scale installed on the vacuum circuit allows constant control of the vacuum level reached in the circuit itself.

Equipped with an **audio-visual alarm** control unit that warns the operator of possible dangerous situations. Present a **filtering system for dust and condensation**. The vacuum tank accelerates the gripping and together with the non-return valve, ensures that the load is not immediately released if there is a sudden power failure.



Horizontal lifting

✓ 4 suction pads



Vertical lifting

✓ Max capacity 440 kg



Manual tilt 0-90°

✓ Safety devices



Technical specification

| | |
|--------------------------|--|
| Application | Not porous stones and materials |
| Lifting capacity | 360 kg on model M4A360K 440 kg on model M4A440K |
| Suction pads | Nr. 4 rectangular suction pads mm 480x180 on model M4A360K mm 580x180 on model M4A440K |
| Load movement | 0 – 90° manual tilt |
| Operating system | Compressed air |
| Vacuum system | Vacuum circuit, complete of vacuum reserve and non return valve |
| Control | Manual valve on the lifter's frame Release of the load by dual action security command |
| Standard features | Lifting beam L. 2200 mm On-off double sliding valve with safety Audible and visual low vacuum warning devices Vacuum gauge with colored scale, vacuum filter, non return valves |
| Optional | White gaskets Holder for hoist command Turnable pads 90° |

Kitchen top vacuum lifter

Optional

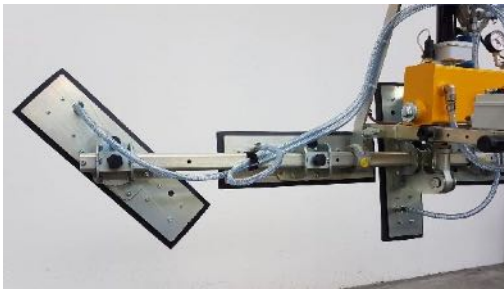

Support for quick rotation of the pads



White gaskets

Technical drawing

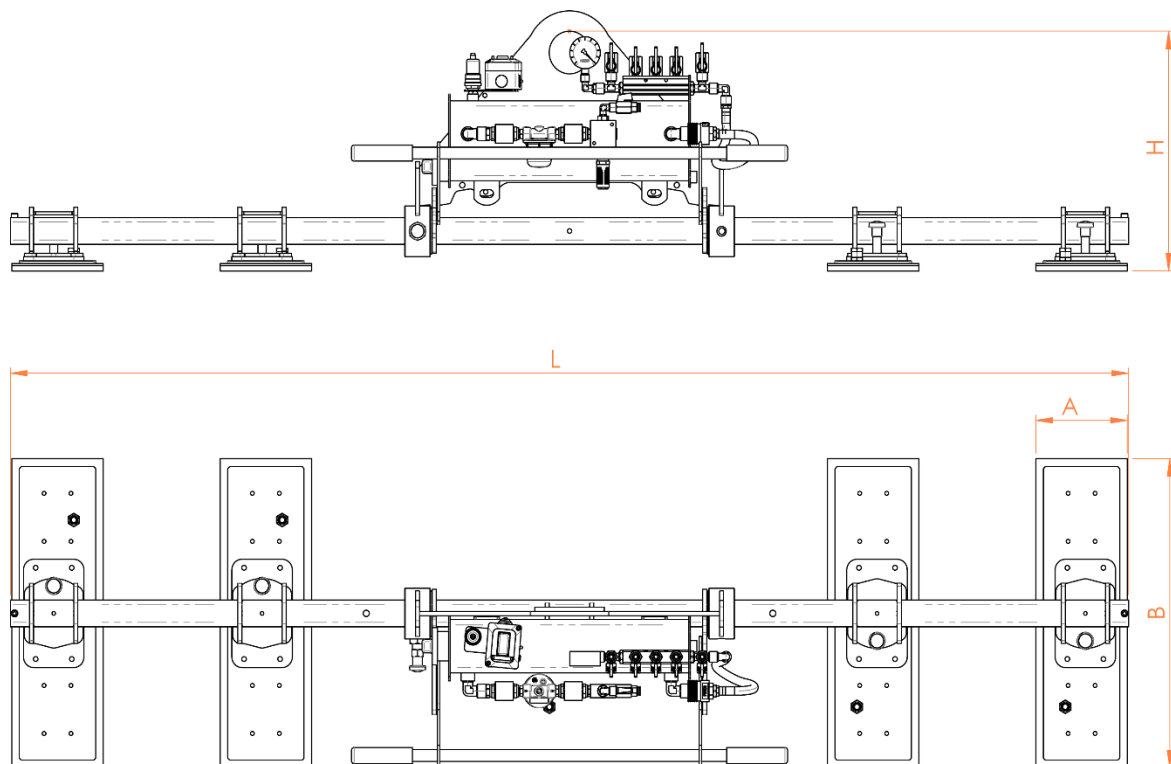

Series -M4A-K

 **Kg max 440**

| Product code | Lifting capacity Kg | A mm | B mm | L mm | H mm |
|--------------|------------------------|---------|---------|---------|---------|
| M4A360K | 360 | 180 | 480 | 2200 | 450 |
| M4A440K | 440 | 180 | 580 | 2200 | 450 |