

Series

M4EB-K

**Kg Max
440**

**Power supply
Batteries**

The M4EB-K is a series of vacuum lifter **specific for kitchen tops** and can have a lifting capacity of 360 kg or 440 kg. These lifters are powered electric on board vacuum pump, which can be 220V 1phase or 400V 3phases. The **manual tilting system** allows the movement of the load from vertical to horizontal and vice versa. It is equipped with an on-off sliding valve against the involuntary release of the load.

The vacuum gauge with coloured scale installed on the vacuum circuit allows constant control of the vacuum level reached in the circuit itself. Equipped with an **audio-visual alarm** control unit that warns the operator of possible dangerous situations. It's present a filtering system for dust and condensation. The vacuum tank accelerates the gripping and together with the non-return valve, ensures that the load is not immediately released if there is a sudden power failure.



Horizontal lifting

 4 suction pad

Vertical lifting

 Max capacity 440 kg

Manual tilt 0-90°

 Safety devices

CE



**made in
ITALY**

Technical specification

Application	Not porous stones
Lifting capacity	360Kg on M4EB360K 440Kg on M4EB440K
Suction pads	Nr. 5 rectangular suction pads M4EB360K mm 480x180 M4EB440K mm 580x180
Load movement	0 – 90° manual tilt
Operating system	Electric vacuum pump 220V 1 ph or 400 3ph - 50Hz
Vacuum system	Vacuum circuit, complete of vacuum reserve and non return valve
Control	Manual valve on the lifter's frame Release of the load by dual action security command
Standard features	Lifting beam L. 2200 mm On-off double sliding valve with safety system Audible and visual low vacuum warning devices Vacuum gauge with colored scale, vacuum filter, non return valves
Optional	White gaskets Support for quick rotation of the pads

Kitchen top vacuum lifter

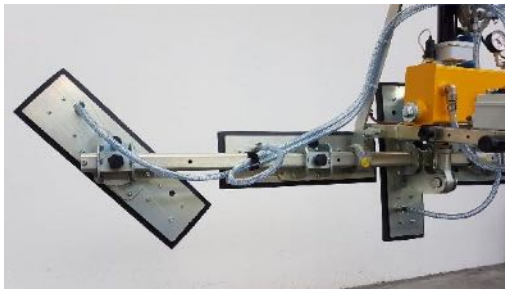
Optional



Support for quick rotation of the pads



White gaskets

Technical drawing

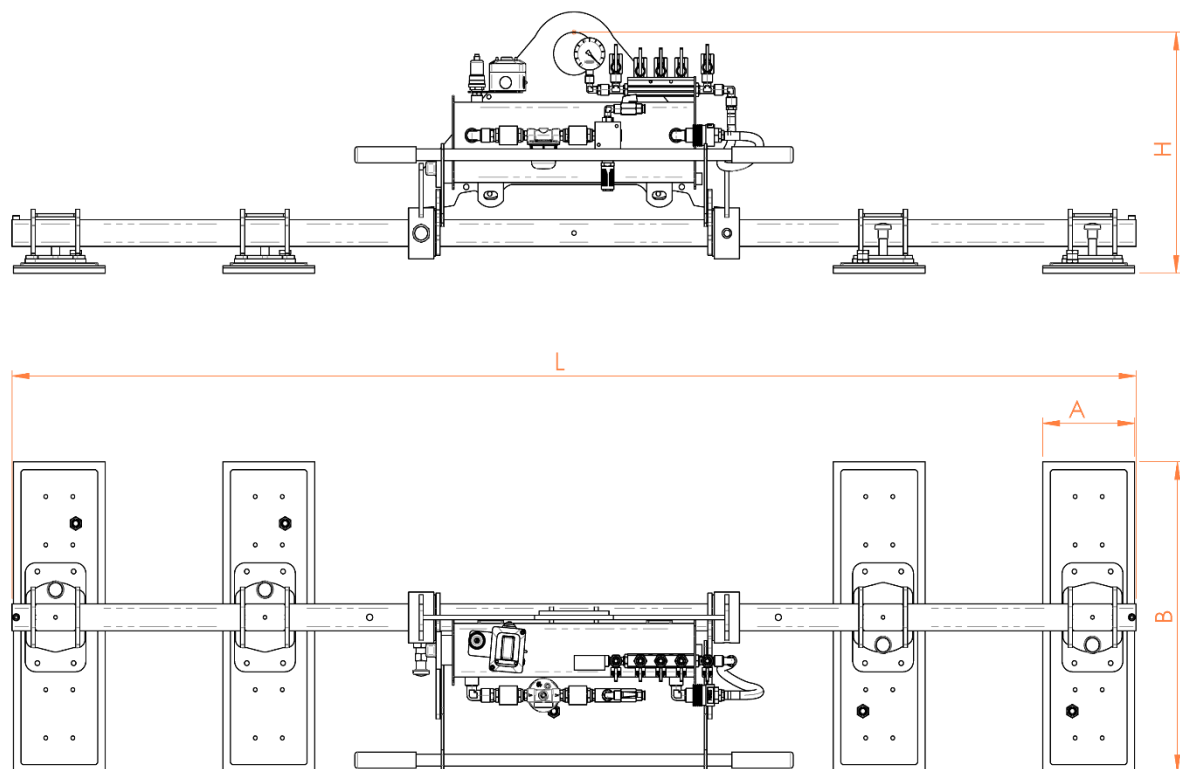

Series -M4EB-K

 **Kg max 440**

Product code	Lifting capacity Kg	A (mm)	B (mm)	L	H
M4EB360K	360	180	480	2200	650
M4EB440K	440	180	580	2200	650