

Righetti

Vacuum lifters
SPECIALISTS

Series
03EB

smart vacuum lifters

Vacuum lifter

 Kg max
1500

 Power supply
Electricity



The 03EB is a series of Vacuum Lifters which contains a wide range of 3-plates models with **capacities ranging from 375 kg to 1500 kg**. The 03EB series is electric powered and it can be produced with voltage 220V 1phase or 400V 3phases. The **hydraulic tilting** system allows a powered vertical – horizontal movement and vice versa; controlled by an electric switch, placed on the lifter's handle.

Thanks to the **individual pads shut-off**, activated through a tap placed on the lifter frame, it's possible to use only the central pad to lift even smaller pieces or semifinished products.

Equipped with an **audio-visual alarm control** unit that warns the operator of possible dangerous situations. The vacuum gauge with coloured scale allows constant control of the vacuum level reached. Present a **filtering system** for dust and condensation.



Horizontal lifting



3 suction pads



Vertical lifting



Max capacity 1500 kg



Hydraulic tilt 0-90°



Safety devices

CE

made in
ITALY

Technical specification

Application	Slabs of marble, granite, quartz. Not porous materials
Lifting capacity	Models up to 1500 kg
Suction pads	Nr. 3 suction pads
Load movement	Hydraulic tilt 0-90°
Operating system	Electric vacuum pump 220V 1 ph or 400 3ph - 50Hz
Vacuum system	Vacuum circuit, complete of vacuum reserve and non return valve
Control	Manual valve on the lifter's frame Release of the load by dual action security command
Standard features	On-off double sliding valve with safety Audible and visual low vacuum warning devices Vacuum gauge with colored scale, vacuum filter, non return valves
Optional	White gaskets Holder for hoist command

Technical drawing

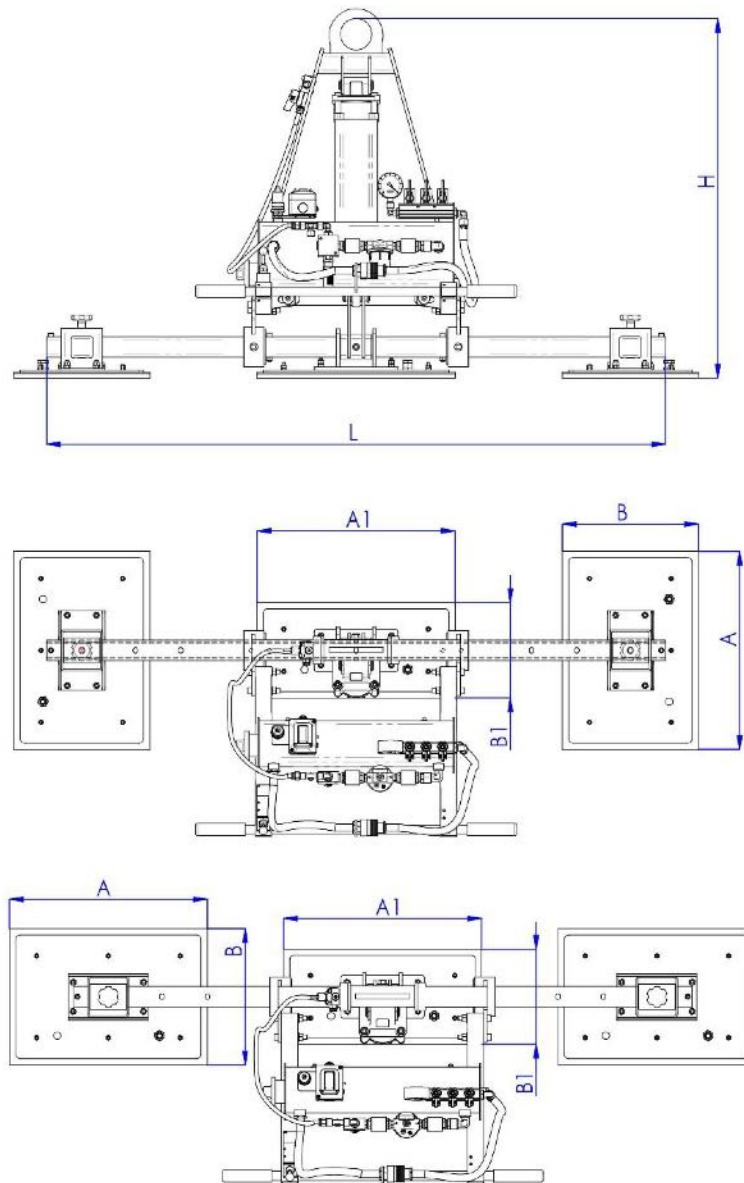

Series 03EB

 **Kg max 1500**

Product code	Lifting capacity KG	Central pad A1 x B1 mm	Lateral pads A x B mm	H mm
03EB 375	375	480 x 230	480 x 230	985
03EB 625	625	480 x 230	480 x 330	985
03EB 750	750	480 x 330	480 x 330	985
03EB 1000	1000	630 x 330	630 x 330	985
03EB 1200	1200	630 x 280	630 x 430	985
03EB 1500	1500	630 x 430	630 x 430	985

*L = 1500mm. On request different lengths of the cross-beam.