

## Series P1A

 Kg max  
1000

**AIR** Power supply  
Compressed Air

The P1A series of Vacuum Lifters is a range of single pad models with lifting capacity **from 125 kg to 1000 kg**. The P1A series is powered by compressed air. The **pneumatic tilting system** allows an assisted movement vertical – horizontal of the load and vice versa, controlled by a joystick on the lifter's handle. The maximum capacity of the lifter depends on the dimension of the suction plates.

Equipped with an **audio-visual alarm** control unit that warns the operator of possible dangerous situations. The vacuum gauge with coloured scale allows constant control of the vacuum level reached. Present a **filtering system for dust and condensation**.



Horizontal lifting

 1 suction pad

Vertical lifting

 Max capacity 1000 kg

Pneumatic tilt 0-90°

 Safety devices



### Technical specification

Application	Not porous materials
Lifting capacity	Models up to 1000 kg
Suction pads	Nr. 1 suction pad
Load movement	Powered tilt 0-90° Activation of tilting by joystick command
Operating system	Compressed air
Vacuum system	Vacuum circuit, complete of vacuum reserve and non return valve
Control	Manual valve on the lifter's frame Release of the load by dual action security command
Standard features	On-off double sliding valve with safety Audible and visual low vacuum warning devices Vacuum gauge with colored scale, vacuum filter, non return valves
Optional	White gaskets Parking stand with wheels Holder for hoist command

### Technical drawing

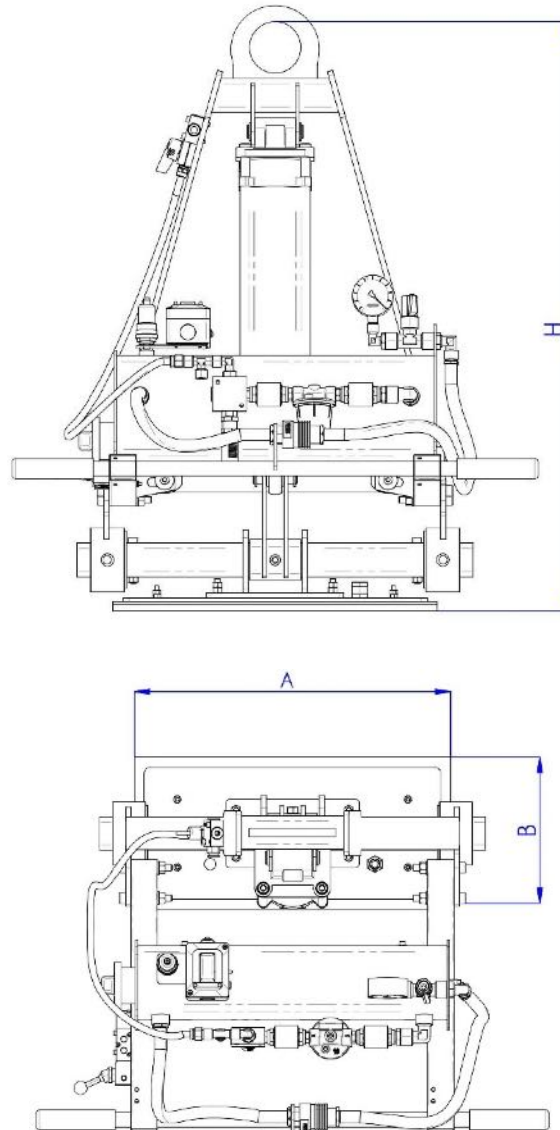

### Series P1A

 **Kg max 1000**

Product code	Lifting capacity	A	B	H
P1A 125	125	480	230	880
P1A 200	200	730	190	880
P1A 250	250	630	280	880
P1A 300	300	630	330	880
P1A 500	500	630	430	880
P1A 750	750	830	480	955
P1A 1000	1000	960	530	955