

Vacuum lifter



Series P4A



AIR Power supply
Compressed Air

The P4A series of Vacuum Lifters is a range of 4-pads models with lifting capacity **from 500 kg to 2000 kg**.

The P4A series is powered by compressed air. The **pneumatic tilting system** allows an assisted movement vertical – horizontal of the load and vice versa.

The maximum capacity of the lifter depends on the dimension of the suction plates.

Equipped with an **audio-visual alarm** control unit that warns the operator of possible dangerous situations. The vacuum gauge with coloured scale allows constant control of the vacuum level reached. Present a **filtering system for dust and condensation**.



Horizontal lifting



4 suction pads



Vertical lifting



Max capacity 2000 kg



Pneumatic tilt 0-90°



Safety devices



Technical specification

Application	Not porous materials
Lifting capacity	Models up to 2000 kg
Suction pads	Nr. 3 suction pads
Load movement	Powered tilt 0-90° Activation of tilting by joystick command
Operating system	Compressed air
Vacuum system	Vacuum circuit, complete of vacuum reserve and non return valve
Control	Manual valve on the lifter's frame Release of the load by dual action security command
Standard features	On-off double sliding valve with safety Audible and visual low vacuum warning devices Vacuum gauge with colored scale, vacuum filter, non return valves
Optional	White gaskets Parking stand with wheels Holder for hoist command

Technical drawing

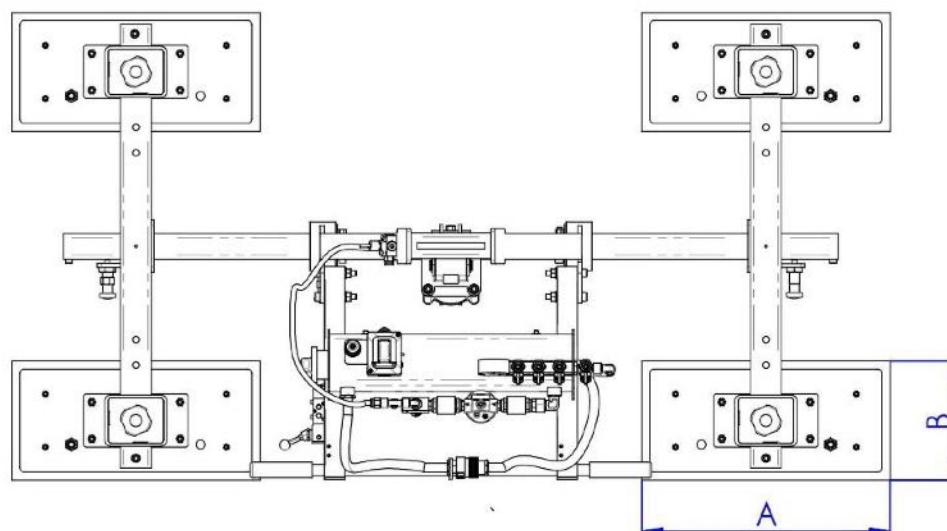
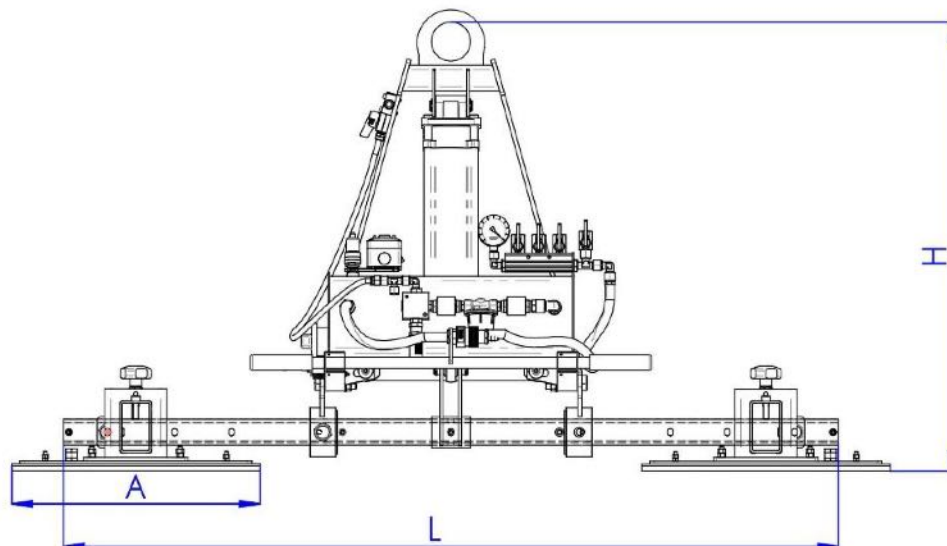

Series P4A

 **Kg max 2000**

Product code	Lifting capacity Kg	A (mm)	B	L	H
P4A 500	500	480	230	1500	880
P4A 1000	1000	480	330	1500	955
P4A 1500	1500	630	330	1500	955
P4A 2000	2000	630	430	1500	955

*L standard dimension is mm 1500; on request mm 2200/2400.