

Model

P5A625K-X

Kitchen top vacuum lifter

 Kg max
625

AIR Power supply
Compressed Air

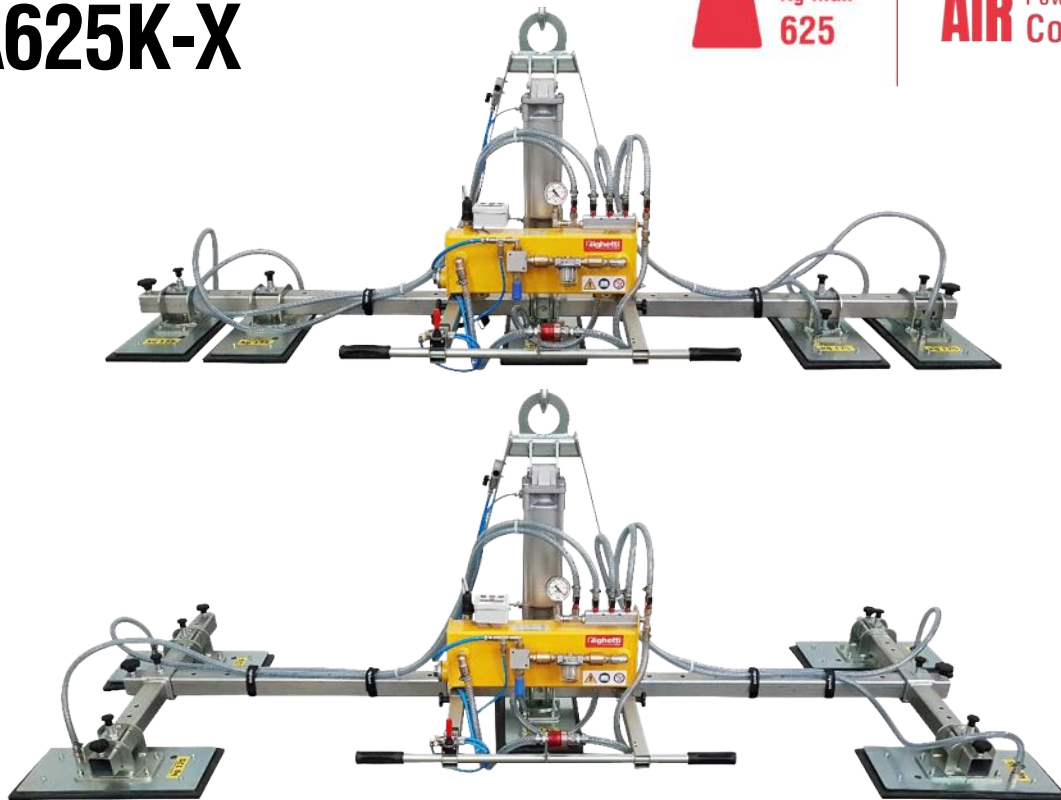

The model P5A625K-X is a **transformable vacuum lifter** with 5 pads and lifting capacity **625 kg**. Thanks to two extension arms (L 830mm), this lifter can change configuration from inline-pads, **suitable for kitchen tops**, to cross-pads, **suitable for big slabs**. The standard central beam is 2400mm long. All the 5 vacuum pads feature **support for quick rotation**.

It is powered by compressed air, featuring a **pneumatic tilting system** which allows an assisted vertical – horizontal movement of the load and vice versa, controlled by a joystick on lifter's handle. It is equipped with an **audio-visual alarm** control unit that warns the operator of possible dangerous situations. The vacuum gauge with coloured scale allows constant control of the vacuum level reached. It is equipped with a **filtering system for dust and condensation**.

Technical specification

Application	Not porous materials – Marble and granite slabs / kitchen tops
Lifting capacity	Kg 625
Suction pads	Nr. 5 rotative suction pads mm 480x230
Load movement	Powered tilt 0-90°. Activation of tilting by joystick command
Operating system	Compressed air
Vacuum system	Vacuum circuit, complete of vacuum reserve and non return valve
Control	Manual valve on the lifter's frame Release of the load by dual action security command
Standard features	On-off double sliding valve with safety Audible and visual low vacuum warning devices Vacuum gauge with colored scale, vacuum filter, non return valves
Optional	White gaskets Parking stand with wheels Holder for hoist command

Kitchen top vacuum lifter

Technical drawing

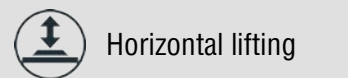
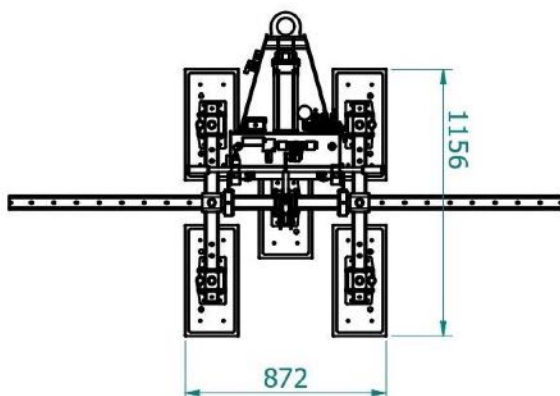
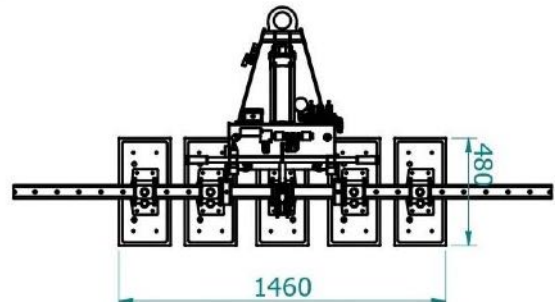
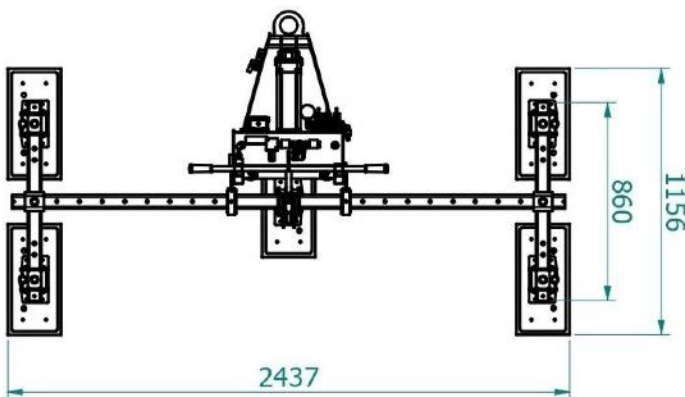
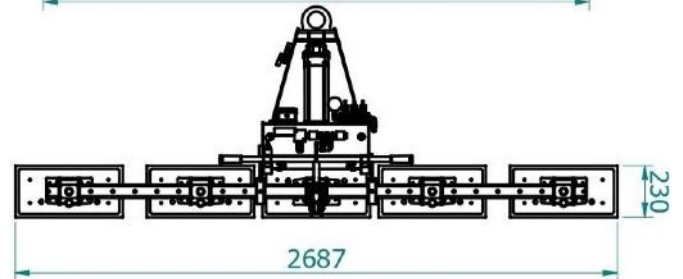
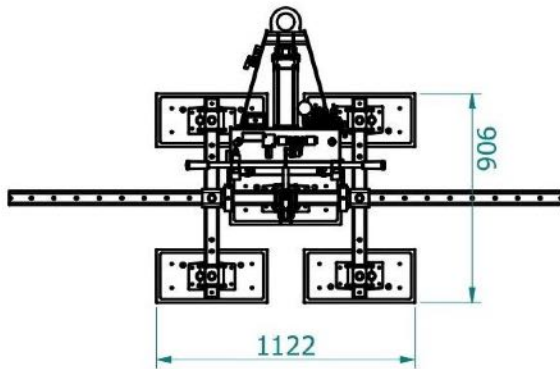
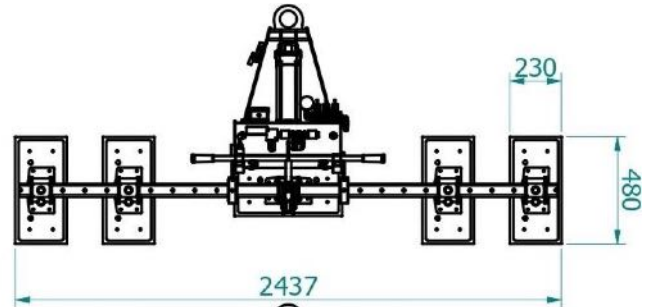
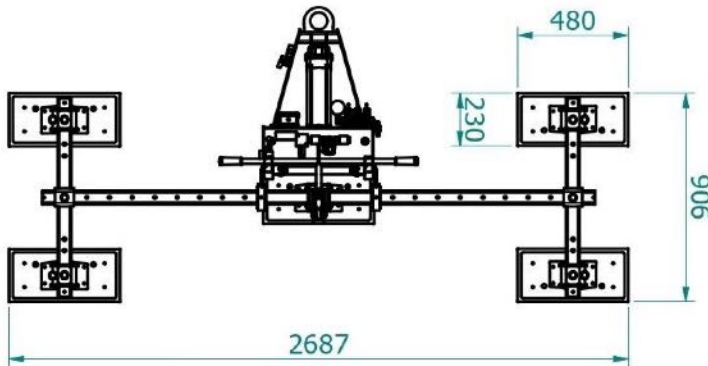

Horizontal lifting



Vertical lifting



Pneumatic tilt 0-90°



Transformable lifter

