

Serie S1-MP

Kg max
1000

Dual operating system
manual **AIR compressed air**

S1 is a series of compact and light vacuum lifters.

The models S1-MP and S1-B are the solution for construction sites or outdoor contexts where the connection to power sources can be tough.

The model S1-B is battery powered, easy to change and to recharge.

The S1-MP model has dual possibility of operating: it can be connected to compressed air or the vacuum can be created by manually pushed pump that allows its use in full autonomy, without need of constant connection to power supply.

The strong but lightweight frame allows the easy handling and installation of the vacuum lifter.

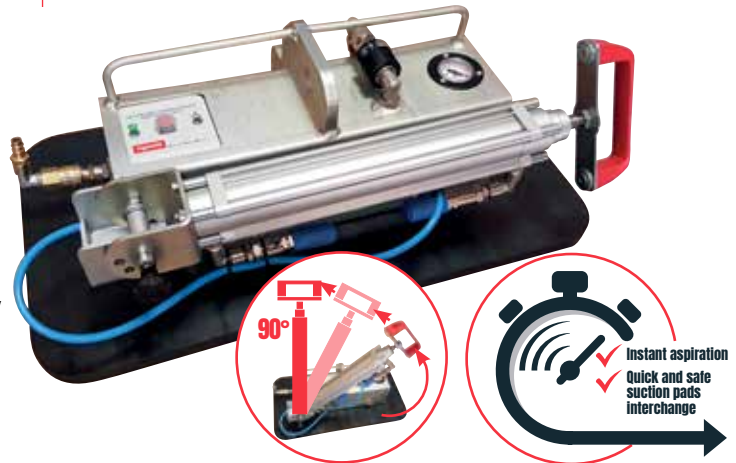

Horizontal lifting



Vertical lifting



Tilting system



Double operating system, manual pump/ compressed air



Interchangeable suction pads



1 suction pad



Low vacuum warning device

CE

made in ITALY

Technical specification

Application	Marble, granite, stones and cement Not porous materials, smooth surface or lightly irregular
Lifting capacity	Depends on the configuration and lifting capacity of suction pad
Suction pad	N. 1 suction pad Quickly and easily suction pads interchange Quickly and easily vacuum gaskets interchange
Load movement	Horizontal or vertical lifting Tilting system 0 – 90°
Operating system	Double operating system • Manual pump to create vacuum, without need of constant connection to power supply • Compressed air
Vacuum system	Vacuum circuit, complete of vacuum reserve and non return valve
Weight of lifter	S1-MP-600.2 kg 18 S1-MP-800 kg 28 S1-MP-1000 kg 32
Control	Slider valve control for suction/release on the lifter Release of the load by dual action security command
Standard features	Regulation of inclination of manual pump 180° On-off double sliding valve with safety Audible and visual low vacuum warning devices Vacuum gauge with coloured scale Vacuum filter

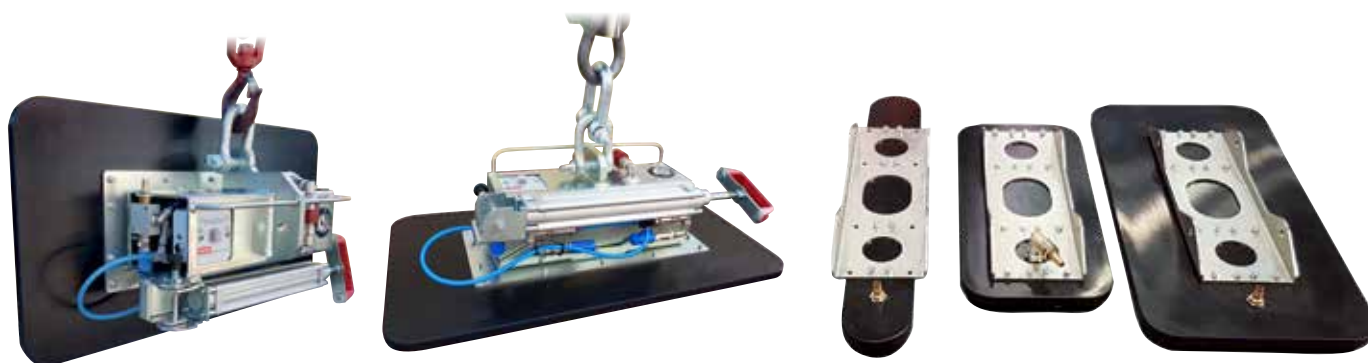

Technical drawing

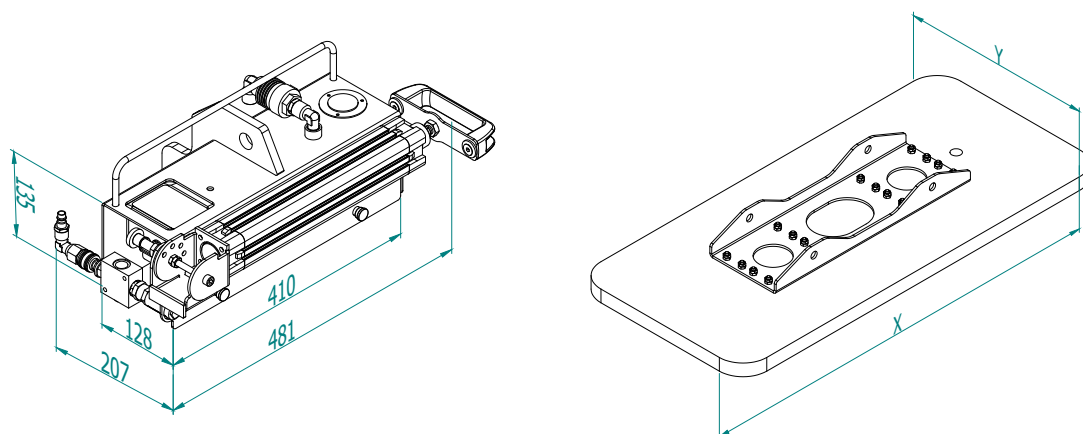

Available models

Max lift capacity Kg	Article code	Suction pad	
		Included	Optional
600	S1-MP-600.2	-	Category A suction pad
800	S1-MP-800	830x420	Category A suction pad
1000	S1-MP-1000	900x480	Category A suction pad

The lifting capacity is established from size of the suction pad applied on the lifter.

Interchangeable suction pads available

Category	Capacity Kg		Pad dimensions mm		Pad article code	Model		
	Horizontal	Vertical	X	Y		S1-MP-600	S1-MP-800	S1-MP-1000
A	50	-	450	100	S1-450100	•	•	•
	100	-	660	100	S1-660100	•	•	•
	200	100	760	150	S1-760150	•	•	•
	250	125	480	230	S1-480230	•	•	•
	300	150	760	200	S1-760200	•	•	•
	450	225	630	330	S1-630330	•	•	•
B	600	300	760	350	S1-760350	•	•	•
B	800	400	830	420	S1-830420	-	Included	•
C	1000	500	900	480	S1-900480	-	-	Included

• Available - Not available **Included** - Standard feature To order, please specify the vacuum lifter model + the desired pad