

## Vacuum lifter



Series

S3-PN

 Kg max  
750

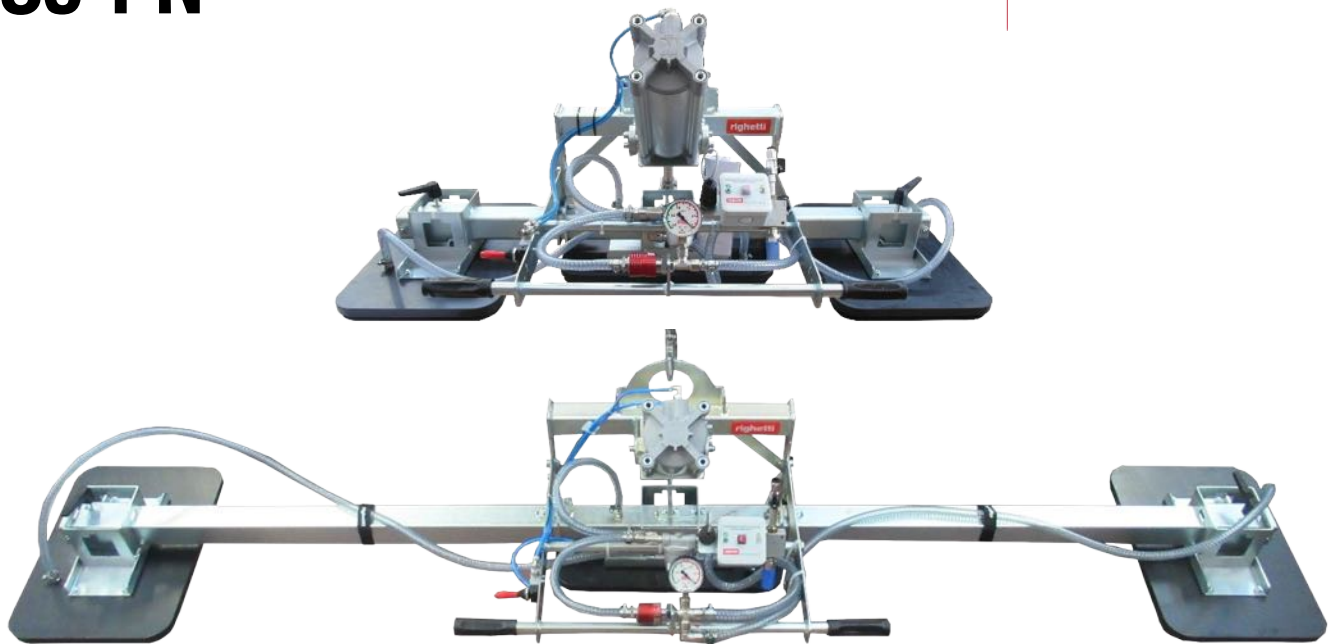
**AIR** Power supply  
Compressed Air

The S3-PN is a series of pneumatic vacuum stone lifters with **lowered frame** and lifting capacity from 375kg up to 750kg. The **tilting system is powered by a pneumatic cylinder** which allows the movement of the load from vertical to horizontal and vice-versa. This lifter is very versatile, by excluding the side plates by turning off a tap on the lifter's frame, it is possible to **use only the central plate** that allows you to lift small items.

The sloped position of the cylinder considerably reduces the height below the hook. In this model the suction pads can be moved along the central beam (available in 1200mm or 2400mm). It is equipped with an **audio-visual alarm** control unit that warns the operator of possible dangerous situations. The vacuum gauge with coloured scale allows constant control of the vacuum level reached. It is present a **filtering system** for dust and condensation.

### Technical specification

<b>Application</b>	Marble and granite slabs - not porous materials
<b>Lifting capacity</b>	Models up to 750 kg
<b>Suction pads</b>	Nr. 3 suction pad
<b>Load movement</b>	Powered tilt 0-90°, controlled by joystick
<b>Operating system</b>	Compressed air
<b>Vacuum system</b>	Vacuum circuit, complete of vacuum reserve and non return valve
<b>Control</b>	Manual valve on the lifter's frame Release of the load by dual action security command
<b>Standard features</b>	On-off double sliding valve with safety Audible and visual low vacuum warning devices Vacuum gauge with colored scale, vacuum filter, non return valves
<b>Optional</b>	White gaskets Holder for hoist command



Horizontal lifting

✓ 3 suction pads



Vertical lifting

✓ Max capacity 750 kg



Pneumatic tilt 0-90°

✓ Safety devices



**Technical drawing**

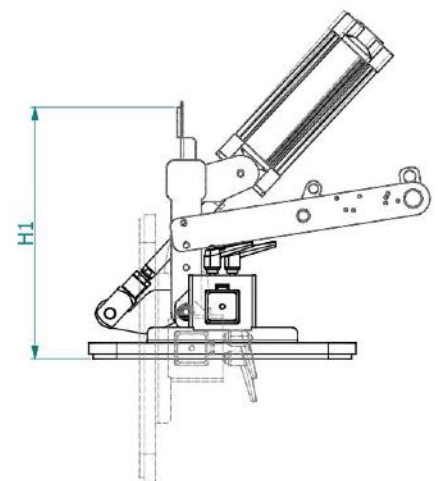
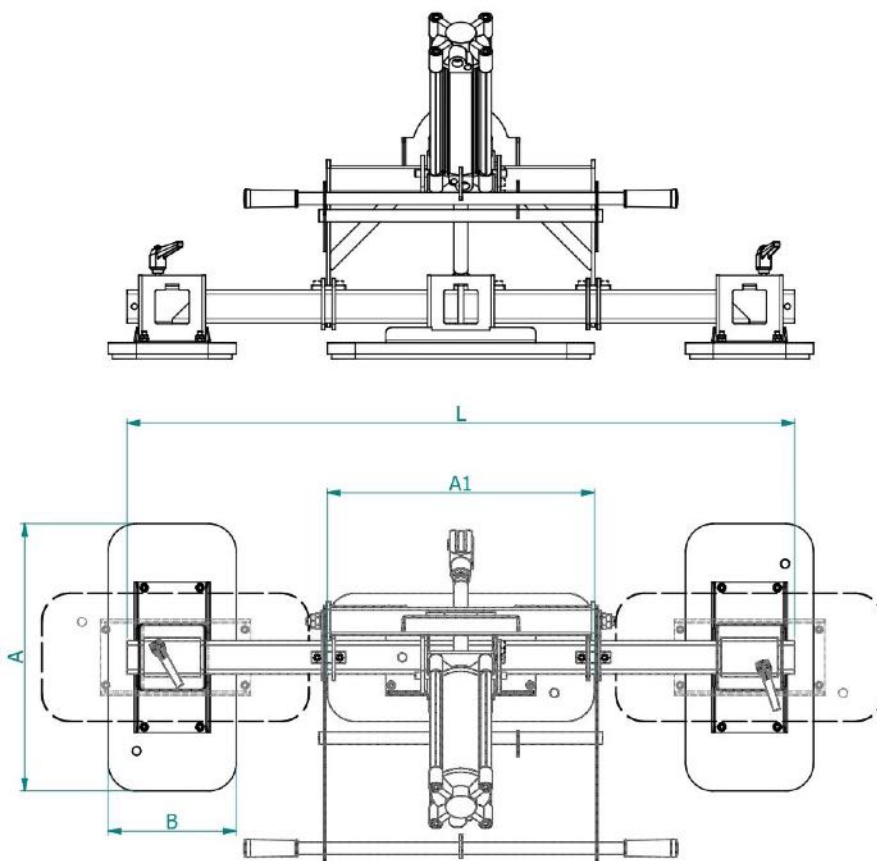

Easily and quickly removable vacuum gaskets



**Series S3-PN**

 **Kg max 750**

Product code	Lifting capacity KG	A x B mm Lateral pads	A1 x B1 mm Central pad	L mm	H1 mm
S3-PN-375	375	480 x 230	480 x 230	1200	440
S3-PN-375/2400	375	480 x 230	480 x 230	2400	440
S3-PN-625	625	480 x 330	480 x 230	1200	440
S3-PN-625/2400	625	480 x 330	480 x 230	2400	440
S3-PN-750	750	480 x 330	480 x 330	1200	440
S3-PN-750/2400	750	480 x 330	480 x 330	2400	440