

## Vacuum lifter



Series

S4-PN-500

 Kg max  
500

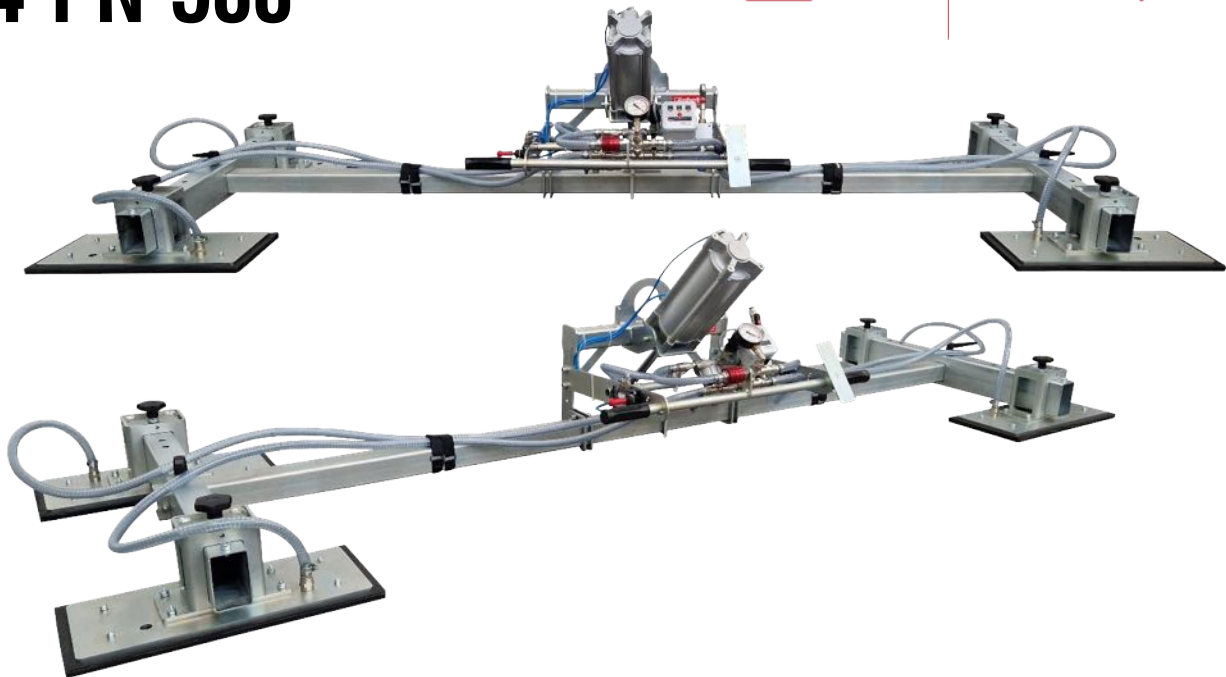
**AIR** Power supply  
Compressed Air

The S4-PN is a series of pneumatic vacuum stone lifters with **lowered frame** and lifting capacity 500kg. The **tilting system is powered by a pneumatic cylinder** which allows the movement of the load from vertical to horizontal and vice-versa. It has 4 rectangular vacuum pads mm 480x230.

The sloped position of the cylinder considerably reduces the height below the hook. In this model the suction pads can be moved along the two crossing arms, and the two arms can be moved along the central beam (available in 1200mm or 2400mm). It is equipped with an **audio-visual alarm** control unit that warns the operator of possible dangerous situations. The vacuum gauge with coloured scale allows constant control of the vacuum level reached. It is present a **filtering system** for dust and condensation.

### Technical specification

<b>Application</b>	Marble and granite slabs - not porous materials
<b>Lifting capacity</b>	500 kg
<b>Suction pads</b>	Nr. 4 suction pad 480 x 230 mm
<b>Load movement</b>	Powered tilt 0-90°, controlled by joystick
<b>Operating system</b>	Compressed air
<b>Vacuum system</b>	Vacuum circuit, complete of vacuum reserve and non return valve
<b>Control</b>	Manual valve on the lifter's frame Release of the load by dual action security command
<b>Standard features</b>	On-off double sliding valve with safety Audible and visual low vacuum warning devices Vacuum gauge with colored scale, vacuum filter, non return valves
<b>Optional</b>	White gaskets Holder for hoist command



Horizontal lifting

✓ 4 suction pads



Vertical lifting

✓ Max capacity 500 kg



Pneumatic tilt 0-90°

✓ Safety devices



**Technical drawing**

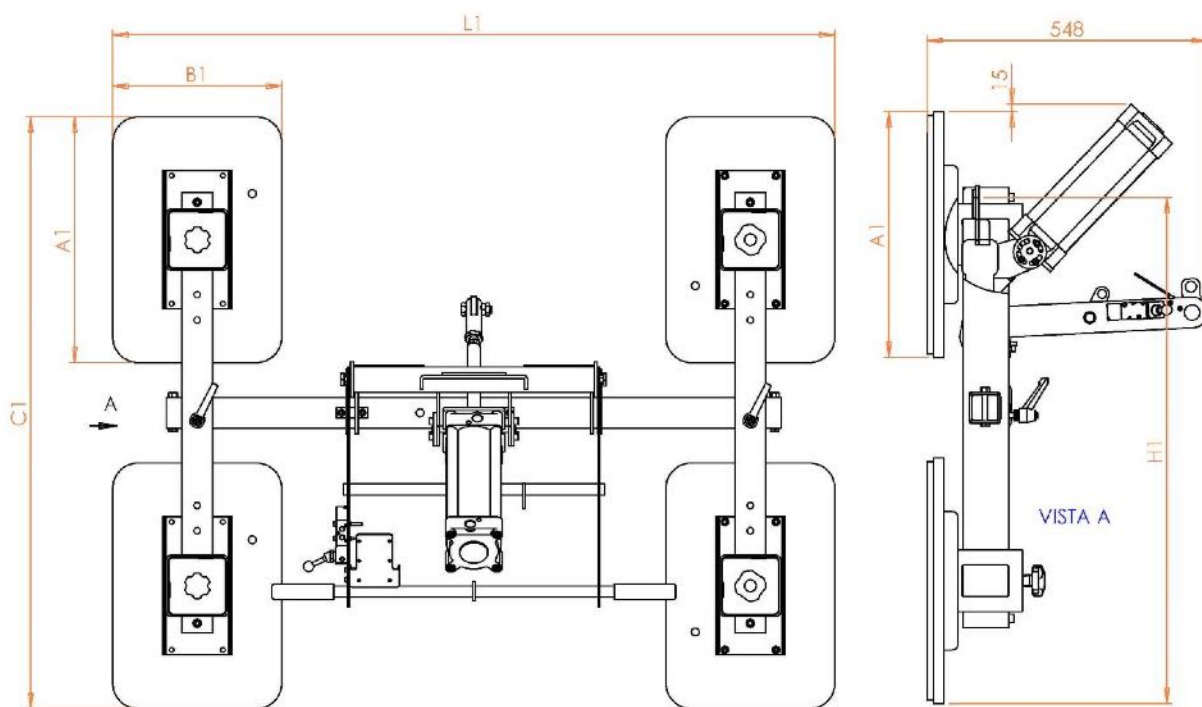

**Series S4-PN**

 **Kg max 500**

Product code	Lifting capacity KG	Dimension od pads mm	L mm	H mm
S4-PN-500	500	480 x 230	1200	450
S4-PN-500/2400	500	480 x 230	2400	450