

# Righetti

smart vacuum lifters

## Vacuum glass lifter

Model

### VA2 RP

 Kg max  
200

**AIR** Power supply  
Compressed Air



The model VA2 RP is a **vacuum glass lifter specific for indoor use**, with two suction pads d. 390 mm, compressed air powered with lifting capacity up to 200Kg.

The lifter features **a vertically fixed frame combined with a 90° pneumatic rotation**. The rotation is performed with the aid of a pneumatic cylinder and is controlled via the joystick on the lifter's frame.

It is equipped with an audio-visual alarm unit that warns the operator of possible dangerous situations. The vacuum gauge with coloured scale allows constant control of the vacuum level reached. It features a **filtering system** for dust and condensation.



90° pneumatic rotation



Safety devices



2 suction pads



Ideal for processing use

CE

made in  
ITALY

### Technical drawings

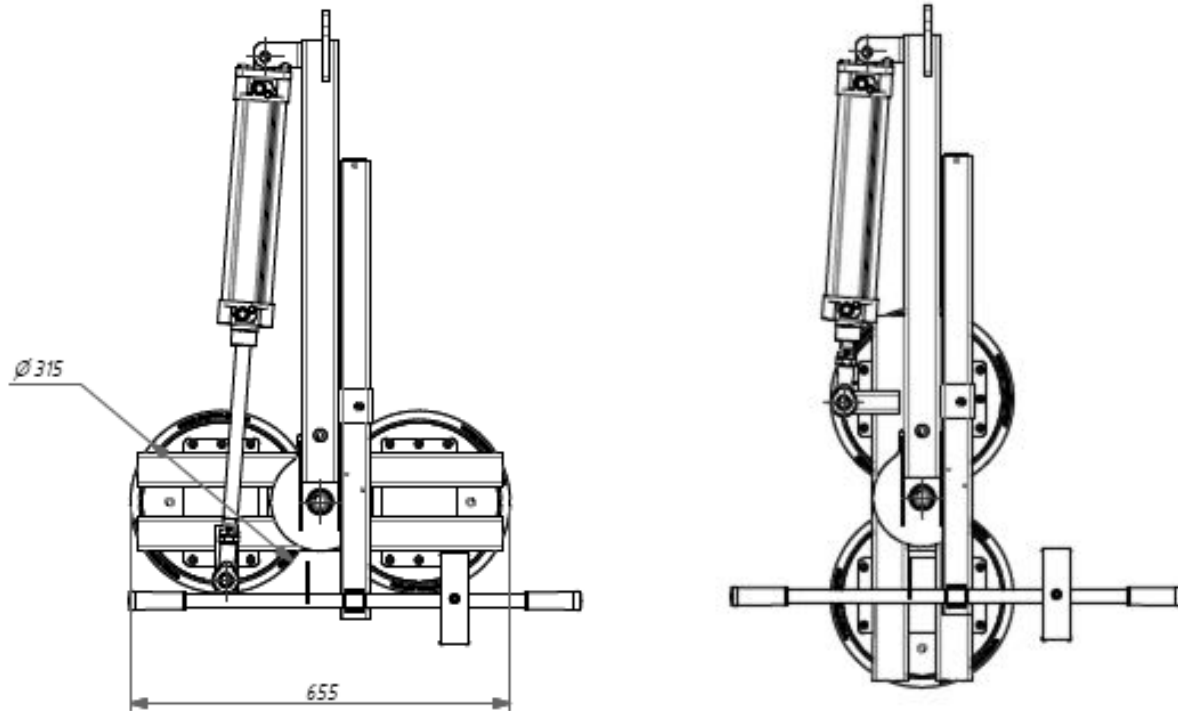

### Technical specification

<b>Application</b>	Glass panels
<b>Lifting capacity</b>	Max 200 kg
<b>Suction pads</b>	No. 2 round suction pads specific for glass Lipped pads with safety ring
<b>Pad spread</b>	655 x 315 mm
<b>Load movement</b>	90° pneumatic rotation
<b>Operating system</b>	Compressed air
<b>Vacuum system</b>	Single vacuum circuit with vacuum reserve and non return valve
<b>Weight of lifter</b>	Kg 58
<b>Control</b>	Manual on off valve on the lifter's frame Release of the load by dual action security command Joystick for rotation control
<b>Standard features</b>	Audible and visual low vacuum warning devices Vacuum gauge Vacuum filter Adjustable pads position