

Righetti

smart vacuum lifters

Model

VEB4+4 RCEBE d4

 Kg max
1200

 Power supply
Electricity

The model VEB4+4 RCEBE d4 is a **modular vacuum glass lifter** with electric movements. On VEB4+4 model, the four external suction pads are on removable extension arms that permit to increase the lifting capacity and the pad spread. The pad arms can be removed quickly and easily. In configuration with 4 pads, the lifting capacity is 600 kg and is possible to lift small glass panels. With addition of four extension pad arms, the lifting capacity increases to 1200 kg. The VEB4+4 RCEBE d4 vacuum lifter features **powered tilt 0 – 90° and powered 360° rotation**. The aspiration, release, tilting and rotating commands are by push button cable command.

Vacuum glass lifter VEB4+4 RCEBE d4 is **electric powered**, it can be produced with voltage 220V 1phase or 400V 3phases, 50Hz. This model can be used on production area, but also on construction site since it features **dual vacuum circuit** according to EN13155.

This lifter is also available with suction pads d. 310 mm and capacity 400/800 kg (mod VEB4+4 RCEBE). It's also available with electric rotation and manual tilt (VEB4+4 RCEBM); or with manual rotation and electric tilt (VEB4+4 RCMBE).



Electric tilt 0-90°



Capacity max 1200kg



Electric continuous rotation 360°



Safety devices



8 vacuum pads d.390 mm



Dual vacuum circuit

CE

made in
ITALY

Technical drawing

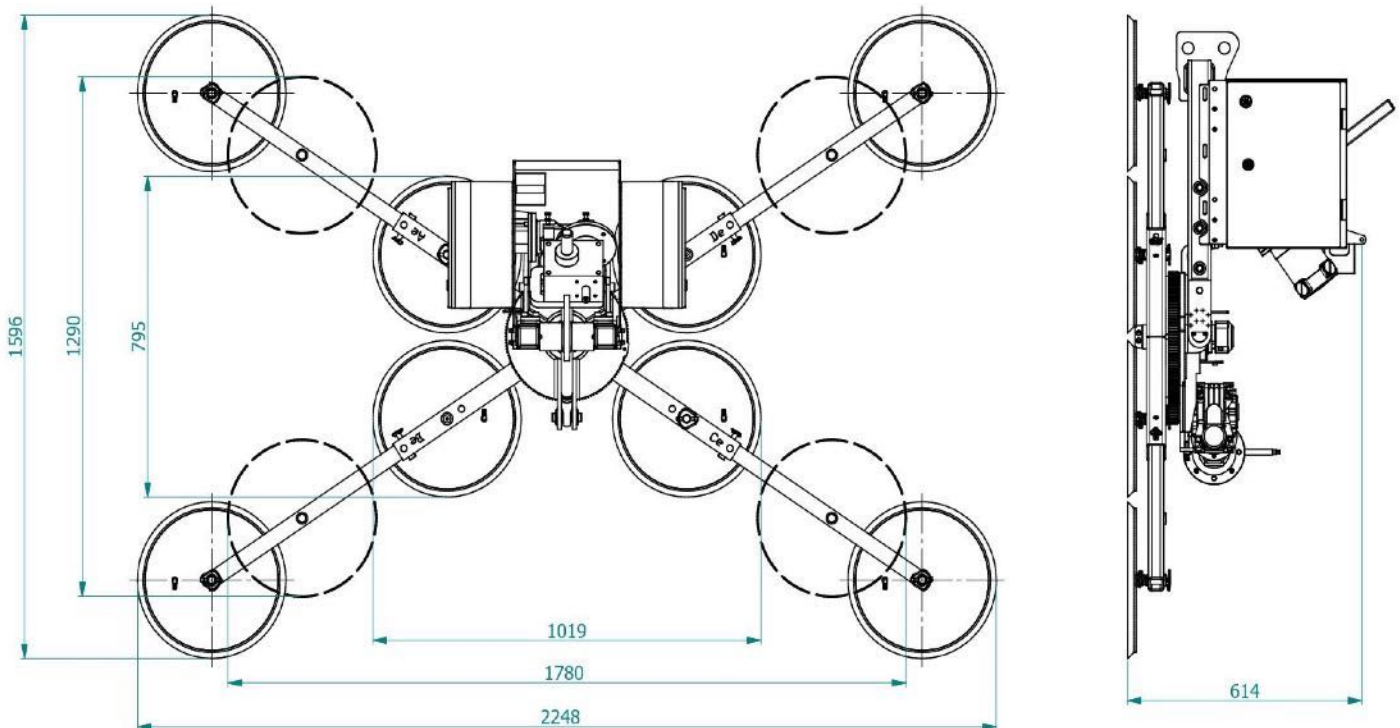

Suction pads		Capacity Kg	Model with		
No.	Ø mm		electric tilt and electric rotation	manual tilt and electric rotation	electric tilt and manual rotation
8	390	1200	VEB4+4 RCEBE d4	VEB4+4 RCEBM d4	VEB4+4 RCMBE d4

Technical specification

Application	Glass panels
Lifting capacity	Max 1200 kg
Suction pads	No. 4+4 round suction pads diameter 390 mm Lipped pads with safety ring
Pad spread	MAX mm 2248 x 1596 – MIN mm 1019 x 795
Load movement	Electric tilt and electric rotation on VEB4+4 RCEBE d4 Manual tilt and electric rotation on VEB4+4 RCEBM d4 Electric tilt and manual rotation on VEB4+4 RCMBE d4
Operating system	Electric operated: 400V 3 phase 50Hz OR 220V single phase 50Hz
Vacuum system	Dual vacuum circuit according to EN13155
Weight of lifter	Kg 160
Structural depth	Mm 614
Control	Suction / release and electric movements controlled by push buttons cable command
Standard features	Audible and visual low vacuum warning devices Vacuum gauge, Vacuum filter Battery charger for alarm system
Optional	Radio remote control