

Righetti

smart vacuum lifters

Model

VEB4 RCEBE d4

Vacuum glass lifter



Kg max
600



Power supply
Electricity

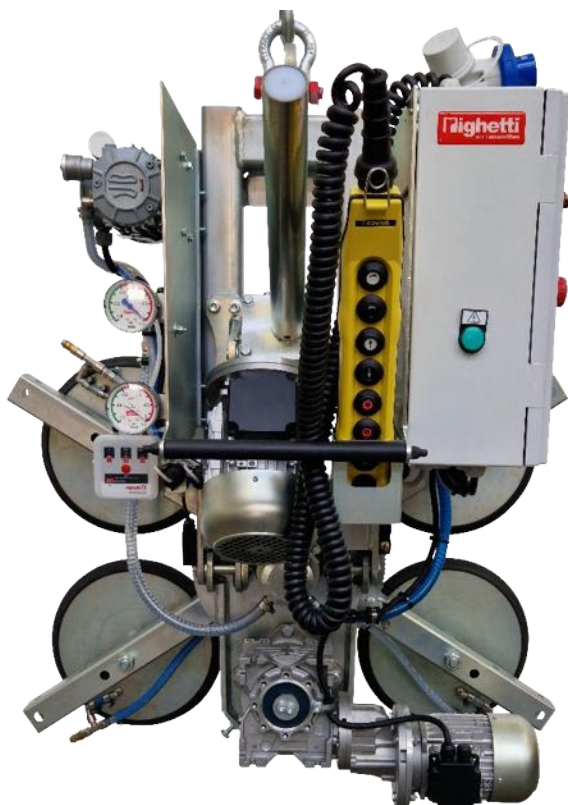

The model VEB4 RCEBE d4 is a **modular vacuum glass lifter** with electric movements and lifting capacity 600kg. The VEB4 RCEBE d4 features **powered tilt 0 – 90°** and **powered continue 360° rotation**. The aspiration, release, tilting and rotating commands are controlled by push button cable command (radio remote control as optional).

Vacuum glass lifter VEB4 RCEBE d4 is **electric powered**, it can be produced with voltage 220V 1phase or 400V 3phases, 50Hz. This model can be used on production area, but also on construction site since it features **dual vacuum circuit** according to EN13155. This lifter is also available with suction pads d. 310 mm and capacity 400 (mod VEB4 RCEBE). It's also available with electric rotation and manual tilt (VEB4 RCEBM d4); or with manual rotation and electric tilt (VEB4 RCMBE d4).



Electric tilt 0-90°



Capacity max 600kg



Electric continuous rotation 360°



Safety devices



4 vacuum pads d.390 mm



Dual vacuum circuit

CE

made in
ITALY

Technical drawing

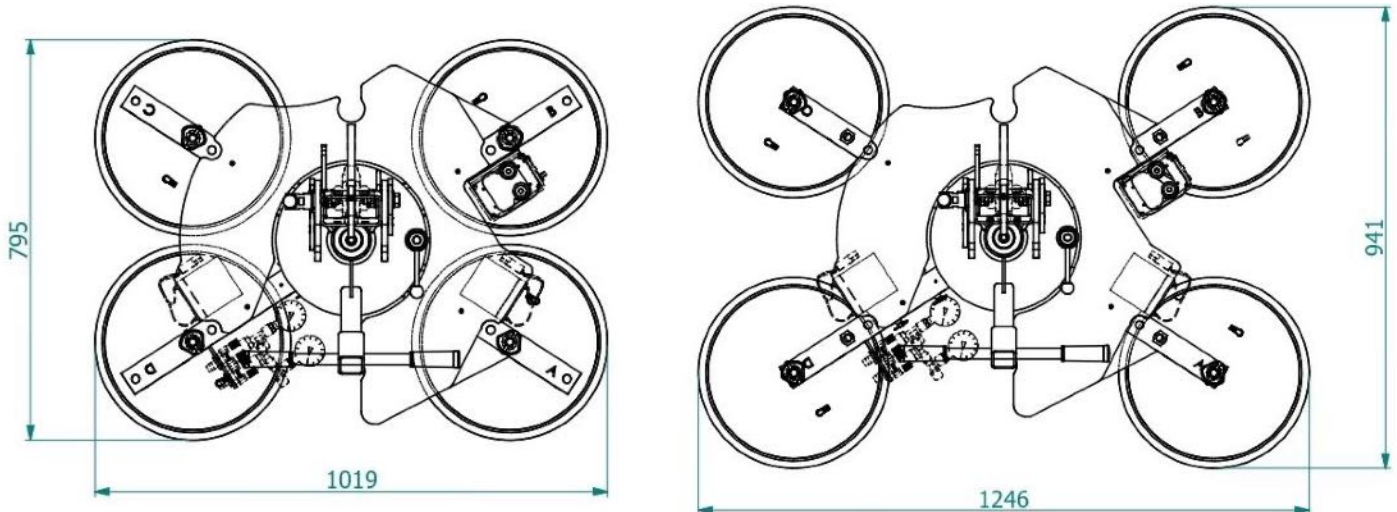

Suction pads		Capacity	Model with		
No.	Ø mm		electric tilt and electric rotation	manual tilt and electric rotation	electric tilt and manual rotation
4	390	600	VEB4 RCEBE d4	VEB4 RCEBM d4	VEB4 RCMBE d4

Technical specification

Application	Glass panels
Lifting capacity	Max 600 kg
Suction pads	No. 4 round suction pads diameter 390 mm Lipped pads with safety ring
Pad spread	MAX mm 1246 x 941 – MIN mm 1019 x 795
Load movement	Electric tilt and electric rotation on VEB4 RCEBE d4 Manual tilt and electric rotation on VEB4 RCEBM d4 Electric tilt and manual rotation on VEB4 RCMBE d4
Operating system	Electric operated: 400V 3 phase 50Hz OR 220V single phase 50Hz
Vacuum system	Dual vacuum circuit according to EN13155
Weight of lifter	Kg 135
Structural depth	Mm 614
Control	Suction / release and electric movements controlled by push buttons cable command
Standard features	Audible and visual low vacuum warning devices Vacuum gauge, Vacuum filter Battery charger for alarm system
Optional	Radio remote control