



HIGHLIGHT

- 1. Rotating yoke:** Stepless 3D movement of the yoke and load.
- 2. Information display:** Monitor battery status, vacuum pressure, and load strain on the wireless remote control.



SL1009 OUTDOOR

LIFTS UP TO 1,000 KG / 2,200 LBS

The SL1009 Outdoor is our most advanced lift. It combines maximum lifting power and reach. Large window sections are easily and precisely handled using the multifunctional, rotary yoke. SL1009 has integrated IoT, and you can now locate and track your machine on an App and can follow operational hours, mandatory services checks and many more options. SL1009 is now controlled by need meaning that the entire system is using less energy.

- Some advantages of CANbus and Trackunit:
1. Vacuum release remotely controlled (Improved safety)
 2. Improved battery life time +2 hours
 3. Remote Diagnostics via Trackunit
 4. Extreme precision

TECHNICAL SPECIFICATIONS

Lifting cap. arm in/out	1,000 / 280 kg - 2,200 / 620 lbs
Lifting height	4,500 mm / 177 in
Extension of arm	2 x 830 mm / 2 x 33 in
Tip from horizontal	42° back / 86° fwd
Side shift	100 mm / 4 in
Charging voltage	230V / 110V
Charging time	Approx. 8 hrs
Battery	4 x 134 Ah AGM
Running period	Up to 8 hrs
Front-wheel drive	2500 W AC
Suction pads	6 x Ø400 mm / Ø16 in
Width	1,010 mm / 43 in
Curb weight	1,480 kg / 3,260 lbs
Class	IP 65



EXTENSION OF ARM
166 CM / 65 IN



LIFTING HEIGHT
450 CM / 177 IN



CONTROLLED BY CANBUS-FREE
TRACKUNIT INCLUDED 3 YEARS

BUILD YOUR SMARTLIFT

Foam-filled tyres	Standard
Electric key switch	■
Special Color	■
Wireless remote	Standard
Hydraulic extension of arm	Standard
Hydraulic rotating yoke	Standard

■ Select the options you need

SL 1009 OUTDOOR

TECHNICAL SPECIFICATIONS

Lifting cap. arm in/out	1000 / 280 kg - 2200 / 620 lbs
Lifting height	4650 mm / 183 in
Extension of arm	2 x 830 mm / 2 x 33 in
Tip from horizontal	42° back / 86° fwd
Side shift	100 mm / 4 in
Charging voltage	230V / 110V
Charging time	Approx. 8 hrs
Battery	4 x 134 Ah AGM
Running period	Up to 10 hrs.
Front-wheel drive	2500 W AC
Suction pads	6 x Ø400 mm / Ø16 in
Width	1020 mm / 40 in
Curb weight	1480 kg / 3260 lbs

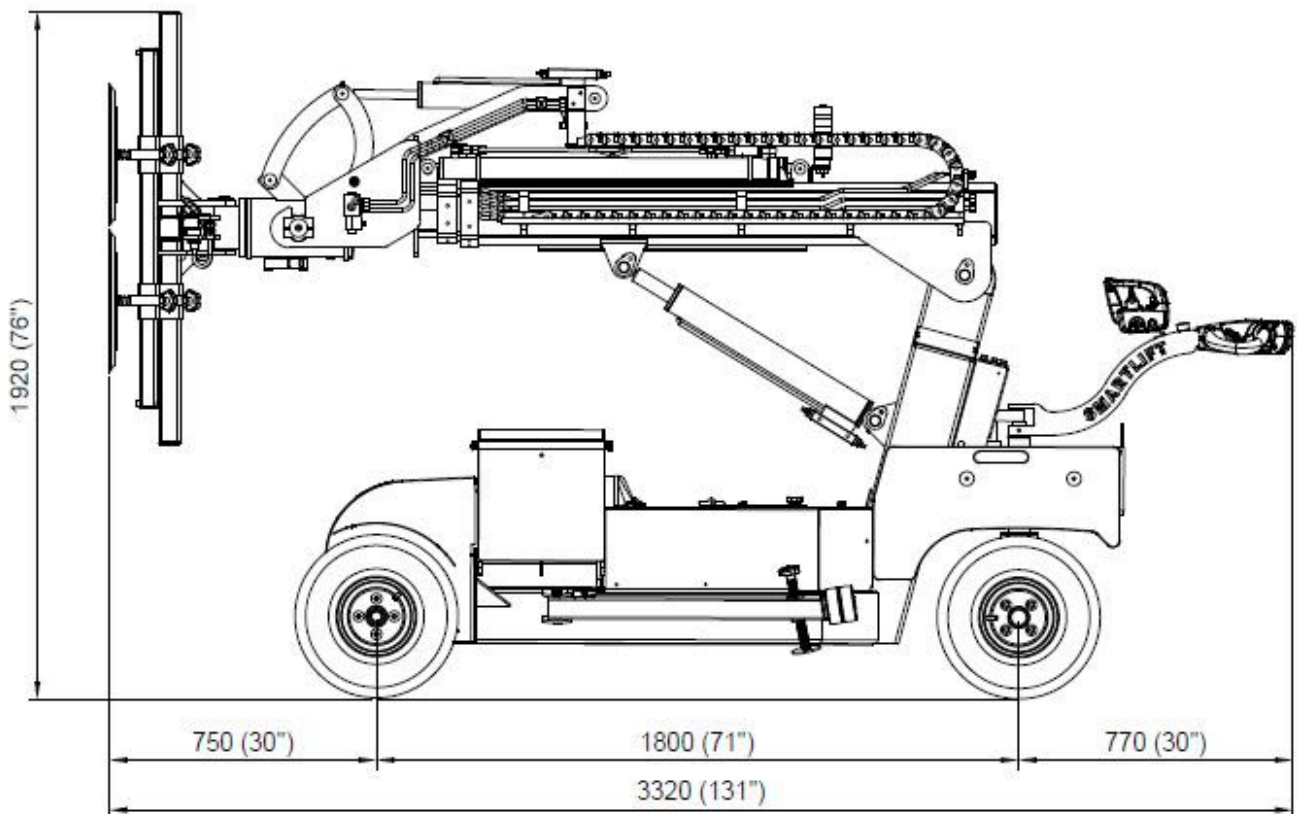
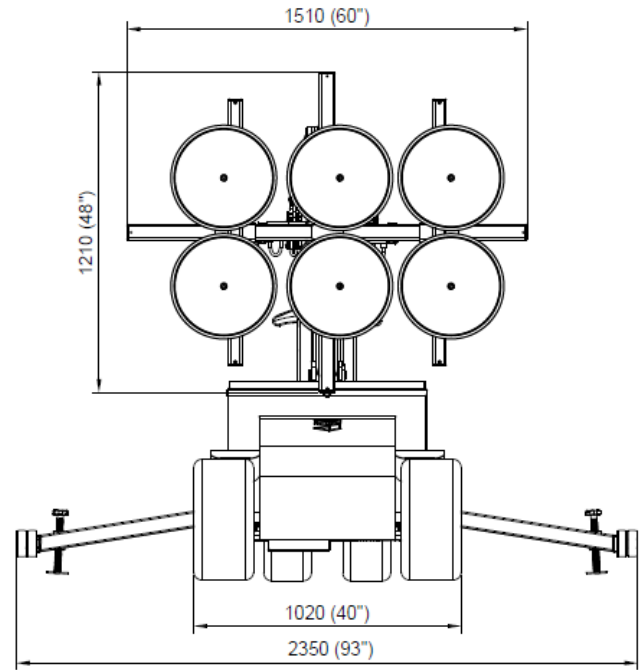

SL1009 Outdoor

