



HIGHLIGHT

Remote control:

All electric Smartlifts have a wired remote control for adjusting the arm and yoke.



SL 380 INDOOR

LIFTS UP TO 380 KG / 840 LBS.

The SL 380 Indoor is a powerful mid-range vacuum lifter for indoor use and it has sideways shifting up to 10 cm for higher flexibility during installation.

The rear-wheel drive makes the lift very manoeuvrable in narrow corridors and small spaces. Puncture proof tires provide a secure grip on most surfaces.



SIDE SHIFT
10 CM /4 IN.



LIFTING HEIGHT
270 CM /106 IN.



The SL 380 Indoor combines lifting power and flexible use indoors

TECHNICAL SPECIFICATIONS

Lifting cap. arm in/out	380/210 kg - 840/460 lbs.
Lifting height	2,700 mm / 106 in.
Extension of arm	500 mm / 20 in.
Tip from horizontal	45° back / 105° fwd.
Side shift	100 mm / 4 in
Charging voltage	230 V / 110V
Charging time	Approx. 8 hrs.
Battery (2 x 12V)	2 x 60 Ah
Running period	Up to 10 hrs.
Rear-wheel drive	700 W DC
Brake	Electro-magnetic
Suction pads	4 x Ø300mm / 4 x Ø12 in.
Width	650 mm / 26 in.
Curb weight	570 kg / 1,260 lbs.

BUILD YOUR SMARTLIFT

Foam-filled tyres	NA
Single Gyro	■
Electric key switch	■
White, non-marking tires	■
Special Color	■
Wireless remote	■
Manual extension of the arm	NA
Electrical extension of the arm	NA
Electrical rotating yoke	NA

■ Select the options you need



SMARTLIFT®

SL 380 INDOOR

TECHNICAL SPECIFICATIONS

Lifting cap. arm in/out	380/210 kg - 840/460 lbs.
Lifting height	2,700 mm / 106 in.
Extension of arm	500 mm / 20 in.
Tip from horizontal	45° back / 105° fwd.
Side shift	100 mm / 4 in
Charging voltage	230 V / 110V
Charging time	Approx. 8 hrs.
Battery (2 x 12V)	2 x 60 Ah
Running period	Up to 10 hrs.
Rear-wheel drive	700 W DC
Brake	Electro-magnetic
Suction pads	4 x Ø300mm / 4 x Ø12 in.
Width	650 mm / 26 in.
Curb weight	570 kg / 1,260 lbs.

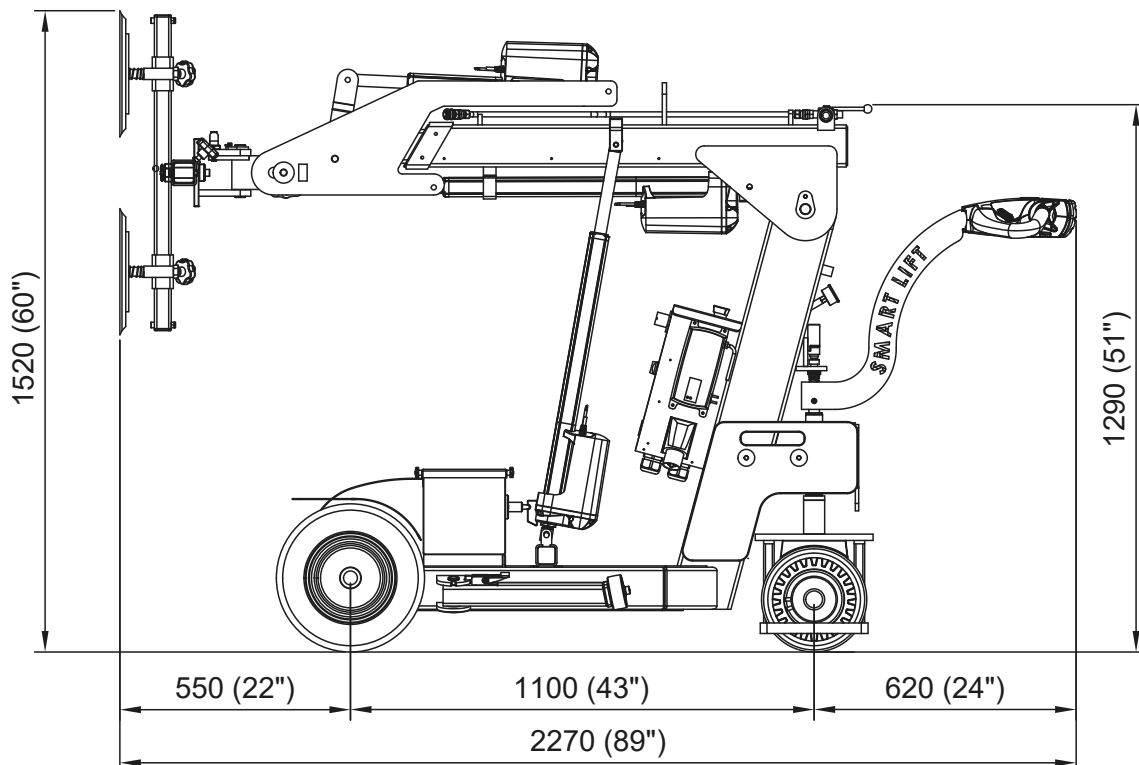
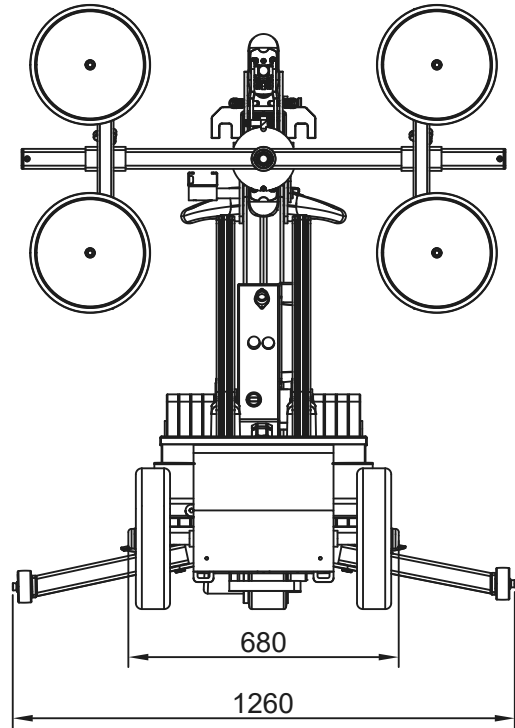

SL380 INDOOR

