



HIGHLIGHT

High Lifter option:
Choose extra manual extension of the arm for longer reach.



Models:
High Lifter Electric RT (HLE RT)

SL409 OUTDOOR

LIFTS UP TO 430 KG / 950 LBS

The new SL409 HLE RT is efficient and hard working. It saves you the cost of extra hands for mounting of elements like glass, windows, granite, marble.

The compact and ruggedized design gets the job done. You get:

- Remote controlled vacuum system
- Speedy tilting
- Save position for repeated mounting
- X/Y movement; the straight movement is easy to control and prevents damages from accidentally bumping into something
- Theft protection, geofencing and remote diagnostics with the built-in Trackunit IoT device
- New gel battery pack
- Enhanced safety features

TECHNICAL SPECIFICATIONS

Model	SL409 Outdoor HLE RT
Lifting cap. arm in/out	430 / 100 kg - 950 / 20 lbs
Lifting height	3,700 mm / 145 in
Extension of arm	600+600 mm / 24+24 in
Tip from horizontal	45° back/90° fwd
Side shift	100 mm / 4 in
Charging voltage	230 V / 110 V
Charging time	Approx. 8 hrs
Running period	Up to 10 hrs
Front-wheel drive	1500 W AC
Suction pads	4 x Ø 300 mm / 4 x Ø12 in
Width	820 mm / 32 in
Curb weight	Up to 730 kg / 1,600 lbs
Class	IP 65



EXTENSION OF ARM
UP TO 120 CM / 48 IN



LIFTING HEIGHT
UP TO 370 CM / 145 IN



Choose the High Lifter version for additional reach and lifting height

BUILD YOUR SMARTLIFT

Foam-filled tyres	Standard
Electric key switch	■
White, non-marking tyres	■
Special Color	■
Wireless remote	■
Manual extension (HL)	■
Electrical extension (HLE)	■
Rotation yoke RT (HL RT/ HLE RT)	■

■ Select the options you need

SL409 OUTDOOR

TECHNICAL SPECIFICATIONS

Model	SL409 Outdoor
Lifting cap. arm in/out	430/200 kg - 950/440 lbs
Lifting height	3100 mm/122 in
Extension of arm	600mm/ 24 in
Tip from horizontal	45° back / 90° fwd
Side shift	100 mm / 4 in
Charging voltage	230 V / 110 V
Charging time	Approx. 10 hrs
Running period	Up to 10 hrs
Front-wheel drive	1500 W AC
Suction pads	4 x Ø300 mm / 4 x Ø12 in
Width	820 mm / 32 in
Curb weight	700 kg / 1540 lbs

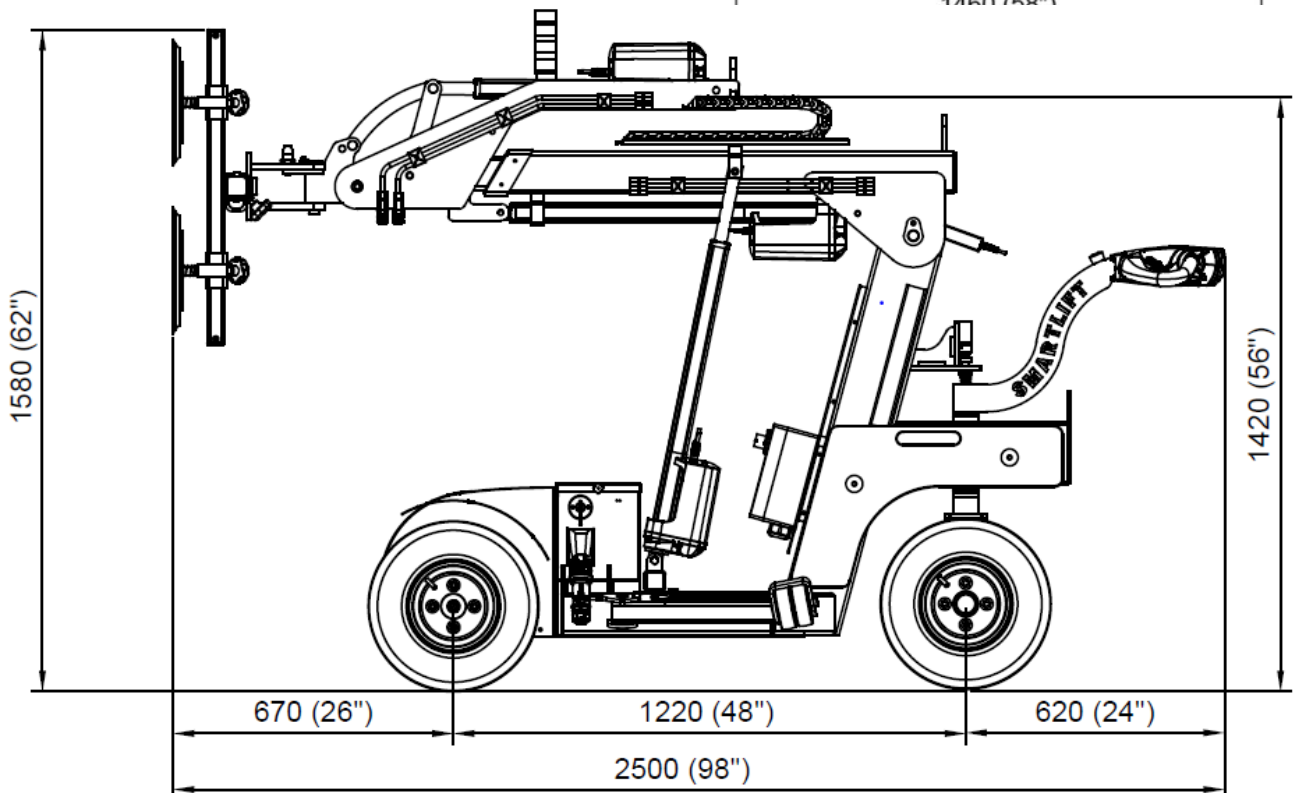
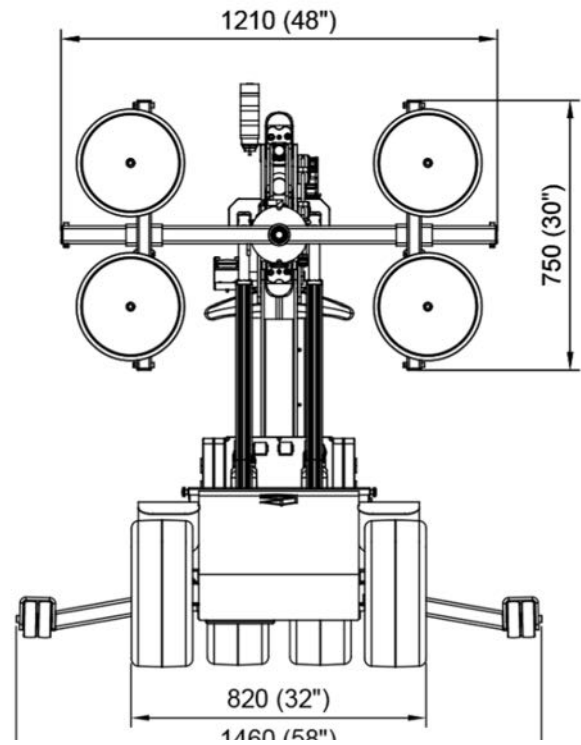

SL 409

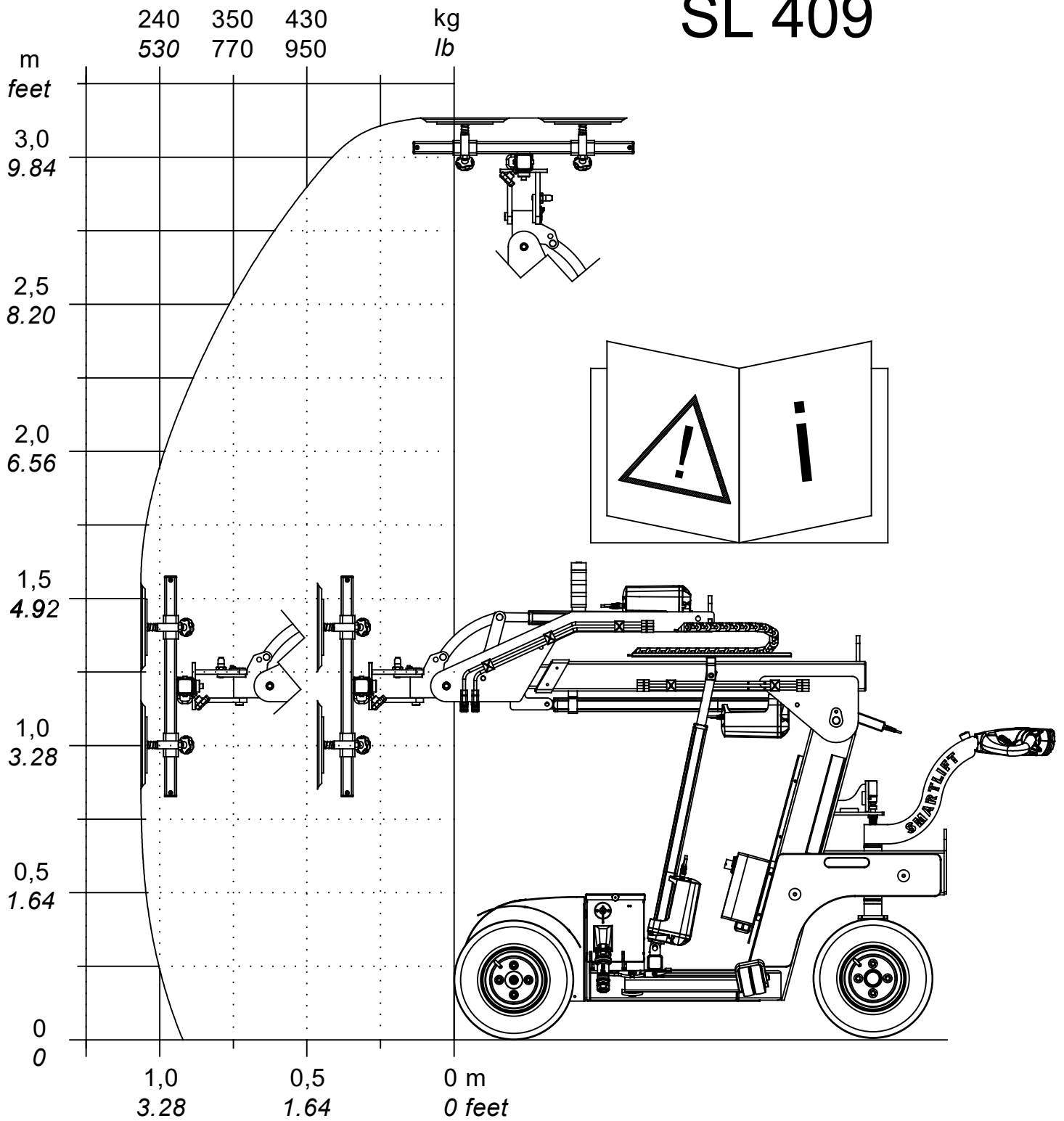

SL409 HL OUTDOOR

TECHNICAL SPECIFICATIONS

Model	SL409 HL Outdoor
Lifting cap. arm in/out	430/100 kg - 950/220 lbs
Lifting height	3650 mm/144 in
Extension of arm	600+600 mm/24 + 24 in
Tip from horizontal	45° back / 90° fwd
Side shift	100 mm / 4 in
Charging voltage	230 V / 110 V
Charging time	Approx. 10 hrs
Running period	Up to 10 hrs
Front-wheel drive	1500 W AC
Suction pads	4 x Ø300 mm / 4 x Ø12 in
Width	820 mm / 32 in
Curb weight	710 kg / 1570 lbs

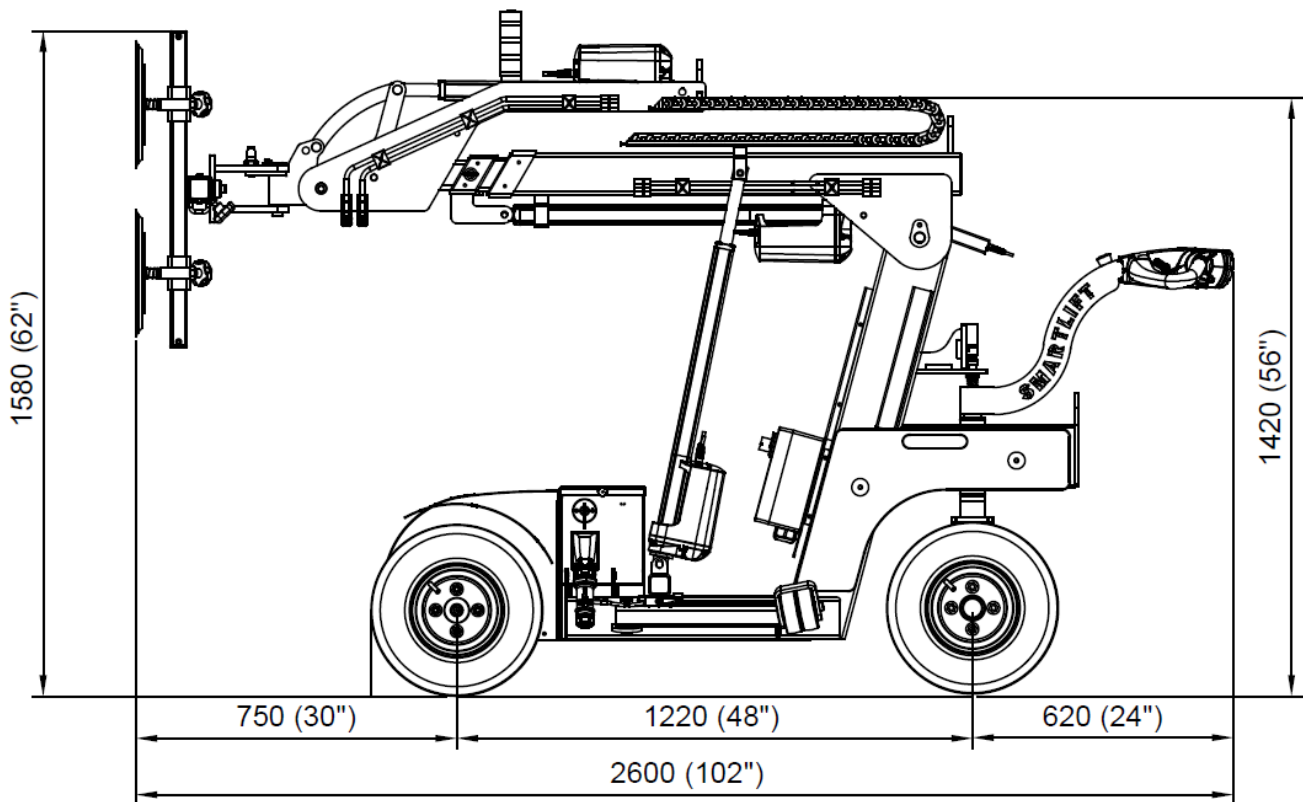
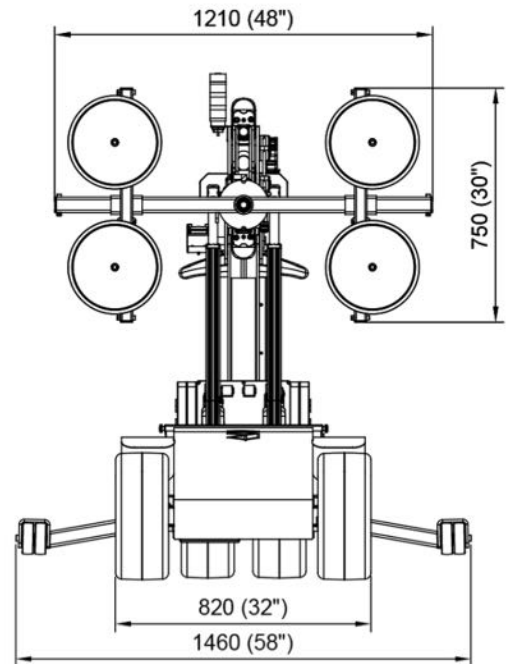

SL 409 High Lifter

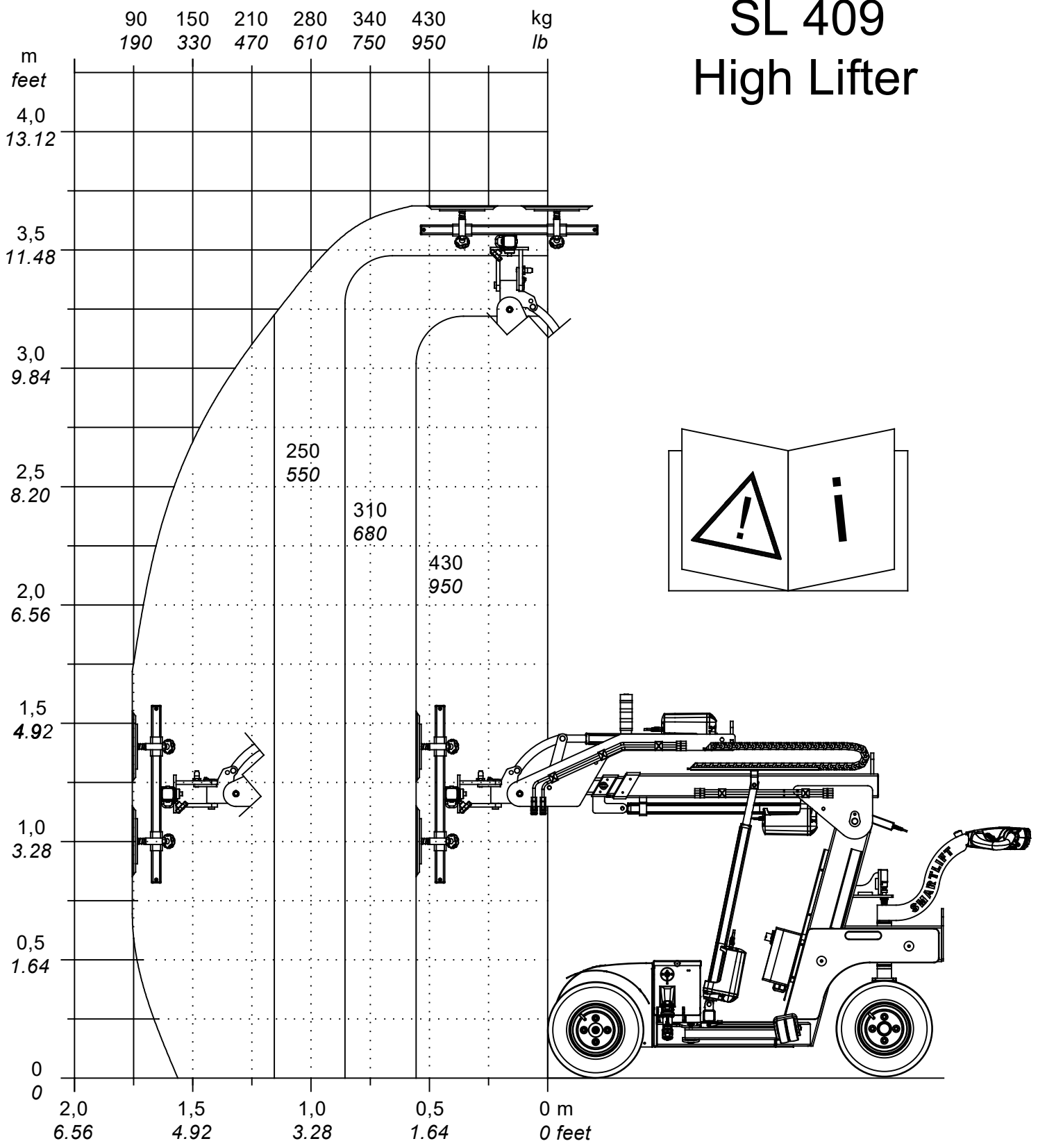

SL 409 OUTDOOR HLE

TECHNICAL SPECIFICATIONS

Lifting cap. arm in/out	430/100kg - 950/220lb
Lifting height	3,650mm / 144in
Extension of arm	600 + 600 mm/24 + 24in
Tip from horizontal	45° back/90° fwd
Side shift	100mm/4in
Charging voltage	230V/110V
Charging time	Approx. 10 hrs
Running period	Up to 10 hrs
Front-wheel drive	1200 W AC
Suction pads	4 x Ø 300mm/Ø12in
Width	820mm / 32in
Curb weight	720kg/1590lb

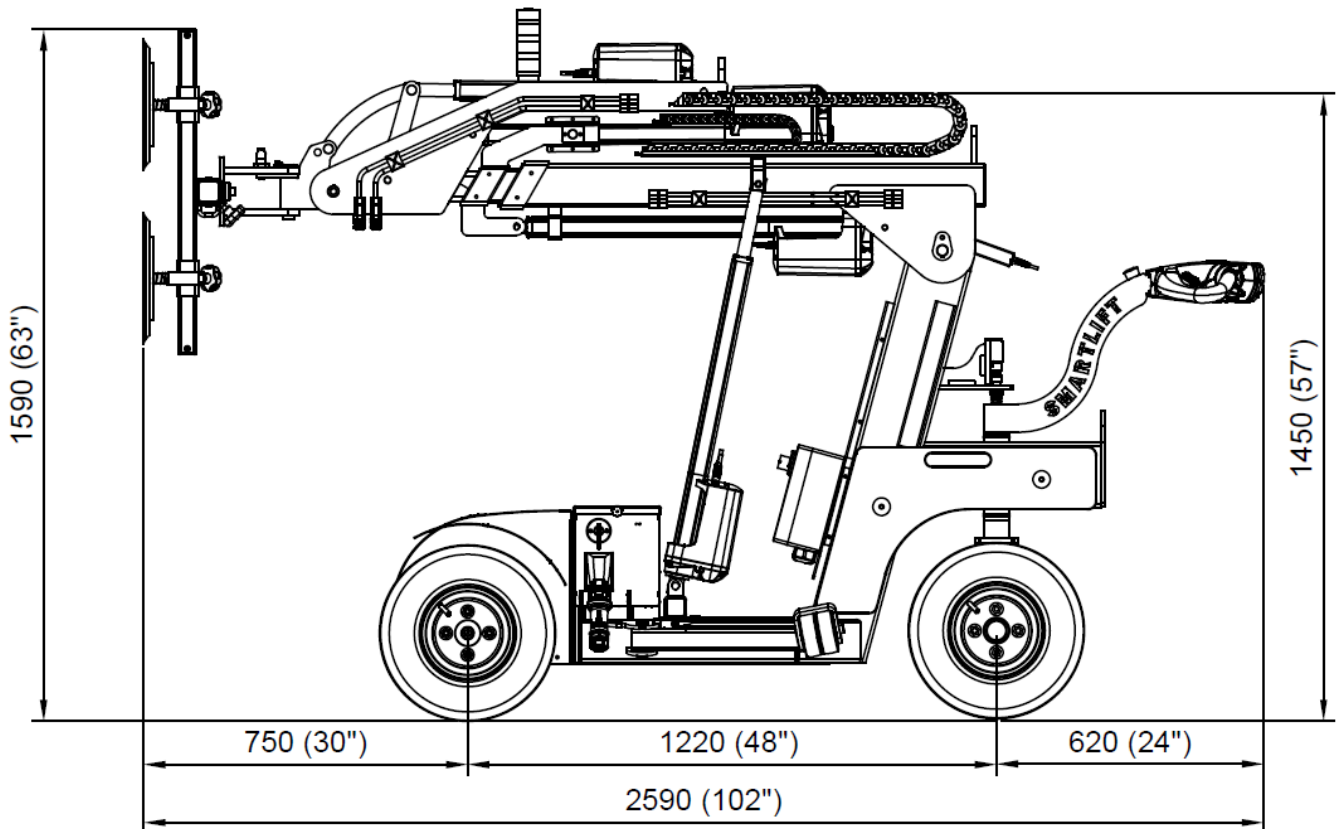
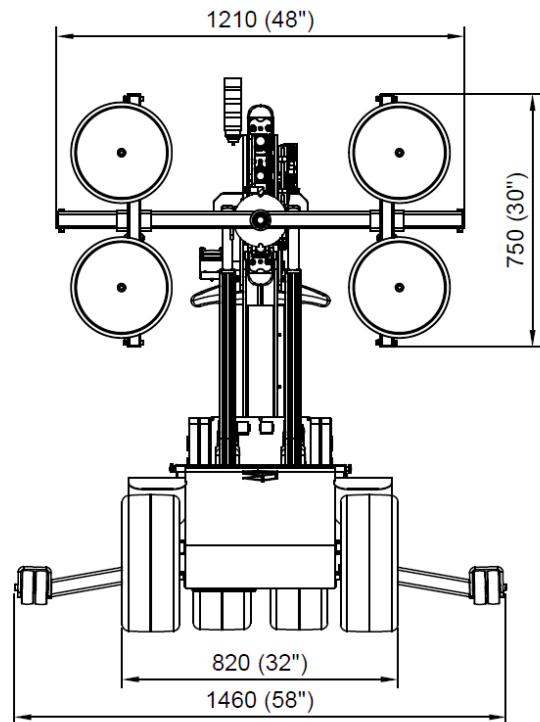

90	150	210	280	340	430	kg
190	330	470	610	750	950	lb

SL 409 High Lifter Electric

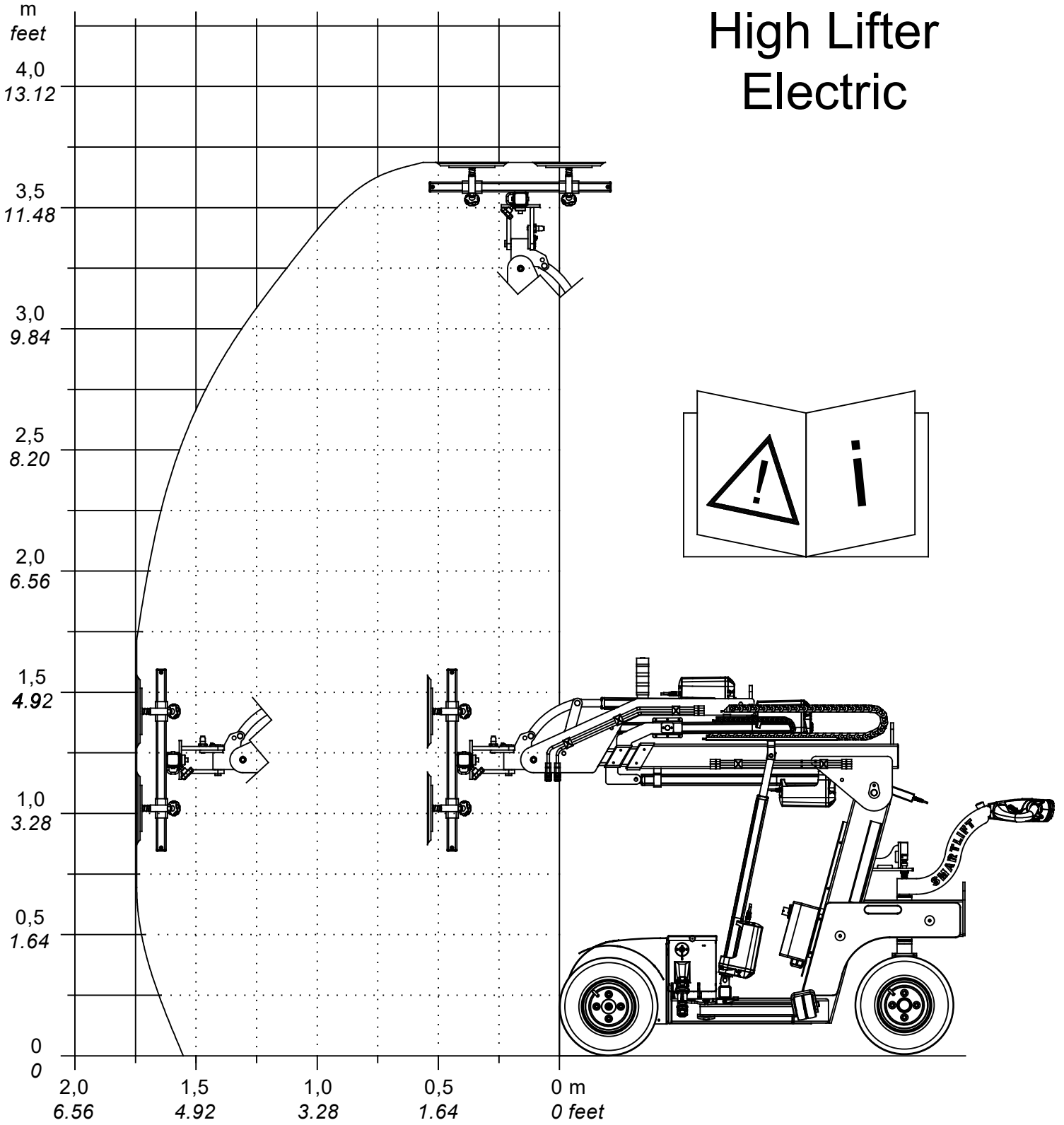

SL409 HLE RT OUTDOOR

TECHNICAL SPECIFICATIONS

Model	SL409 HLE RT Outdoor
Lifting cap. arm in/out	430/100 kg - 950/220 lbs
Lifting height	3650 mm/144 in
Extension of arm	600+600 mm/24 + 24 in
Tip from horizontal	45° back / 90° fwd
Side shift	100 mm / 4 in
Charging voltage	230 V / 110 V
Charging time	Approx. 10 hrs
Running period	Up to 10 hrs
Front-wheel drive	1500 W AC
Suction pads	4 x Ø300 mm / 4 x Ø12 in
Width	820 mm / 32 in
Curb weight	730 kg / 1610 lbs

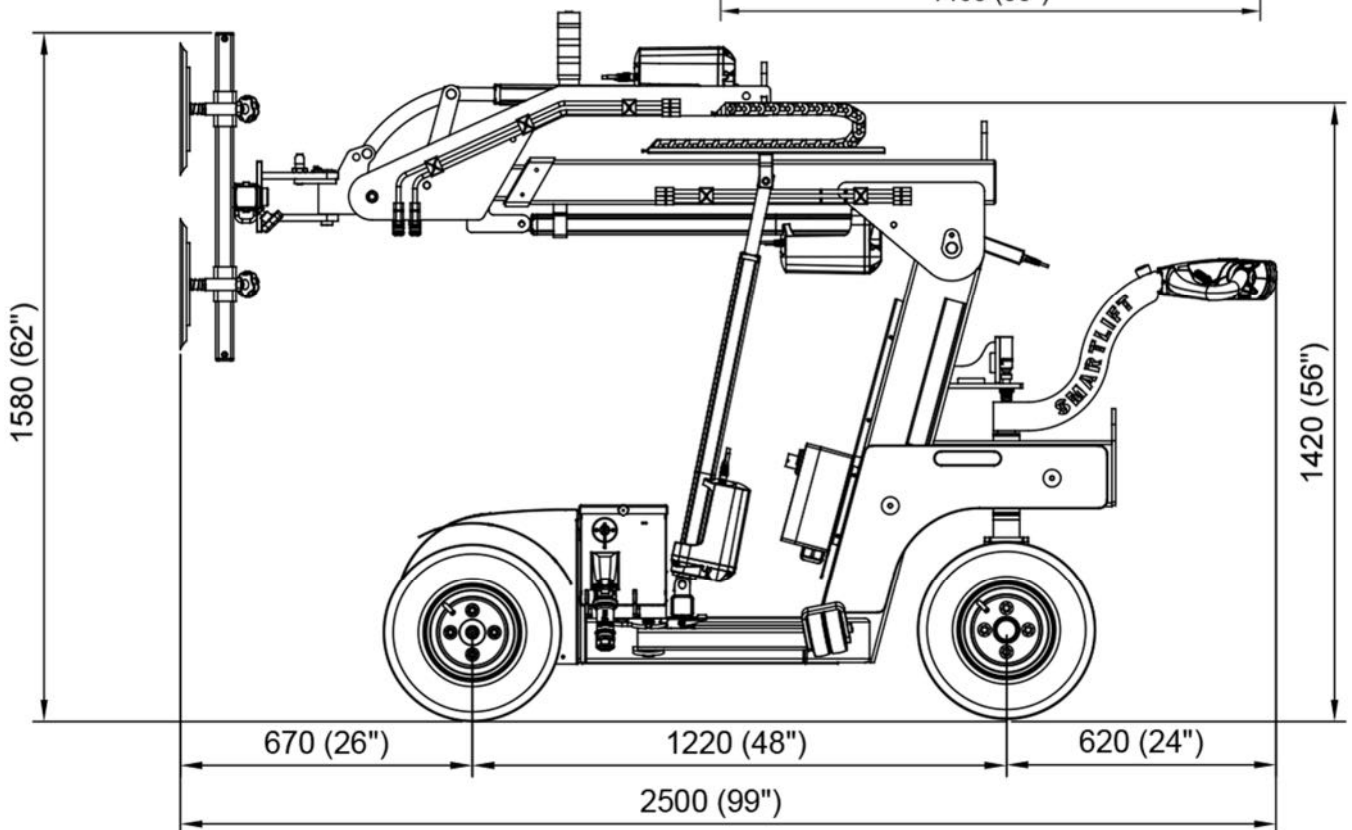
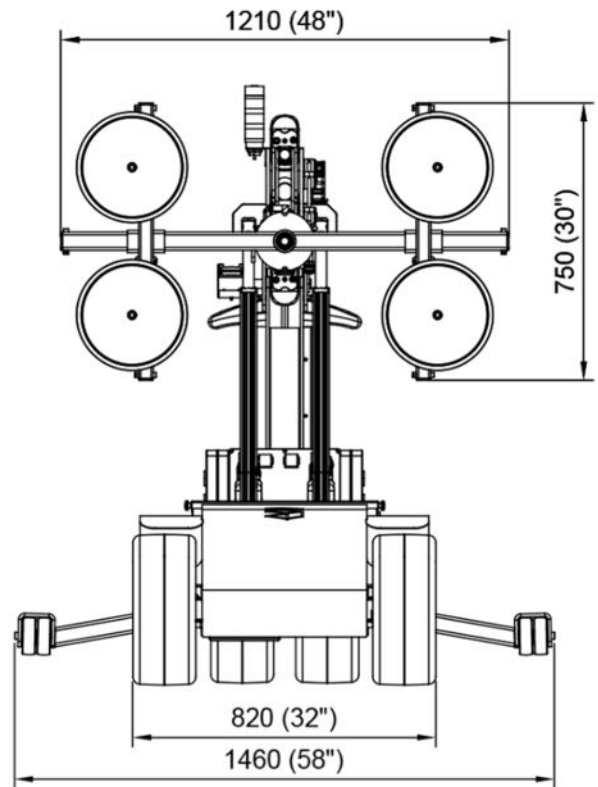

90	140	170	240	330	430	kg
200	310	370	530	730	950	lb

SL 409

High Lifter

Electric

Rotation

