



HIGHLIGHT

Safety first:
Any Smartlift has several safety features built in to prevent overload and accidents.



SL 580 INDOOR

LIFTS UP TO 580 KG / 1,280 LBS.

Do not under estimate this heavy-duty vacuum lifter. The SL 580 Indoor is excellent for handling the heaviest windowpanes, fire doors and sheets of glass without compromising on precision and ease of use.

A slim body width and the rear-wheel drive make it very maneuverable inside buildings or on the factory floor. The puncture proof tires provide a secure grip on most surfaces.



SIDE SHIFT
10 CM / 4 IN.



LIFTING HEIGHT
230 CM / 90 IN.



Our most powerful lift for indoor use

TECHNICAL SPECIFICATIONS

Lifting cap. arm in/out	580/280 kg - 1,280/620 lbs
Lifting height	2,300 mm / 96 in.
Extension of arm	500 mm / 20 in.
Tip from horizontal	25° back / 105° fwd.
Side shift	100 mm / 4 in
Charging voltage	230 V / 110V
Charging time	Approx. 8 hrs.
Battery (2 x 12V)	2 x 80 Ah
Running period	Up to 10 hrs.
Rear wheel drive	1000 W DC
Brake	Electro-magnetic
Suction pads	4 x Ø400mm / 4 x Ø16 in.
Width	780 mm / 31 in.
Curb weight	697 kg / 1,540 lbs.

BUILD YOUR SMARTLIFT

Foam-filled tyres	NA
Single Gyro	■
Electric key switch	■
White, non-marking tires	■
Special Color	■
Wireless remote	■
Manual extension of the arm	■
Electrical extension of the arm	■
Electrical rotating yoke	■

■ Select the options you need



SMARTLIFT®

SL 580 INDOOR

TECHNICAL SPECIFICATIONS

Lifting cap. arm in/out	580/280 kg - 1,280/620 lbs
Lifting height	2,300 mm / 96 in.
Extension of arm	500 mm / 20 in.
Tip from horizontal	25° back / 105° fwd.
Side shift	100 mm / 4 in
Charging voltage	230 V / 110V
Charging time	Approx. 8 hrs.
Battery (2 x 12V)	2 x 80 Ah
Running period	Up to 10 hrs.
Rear wheel drive	1000 W DC
Brake	Electro-magnetic
Suction pads	4 x Ø400mm / 4 x Ø16 in.
Width	780 mm / 31 in.
Curb weight	697 kg / 1,540 lbs.

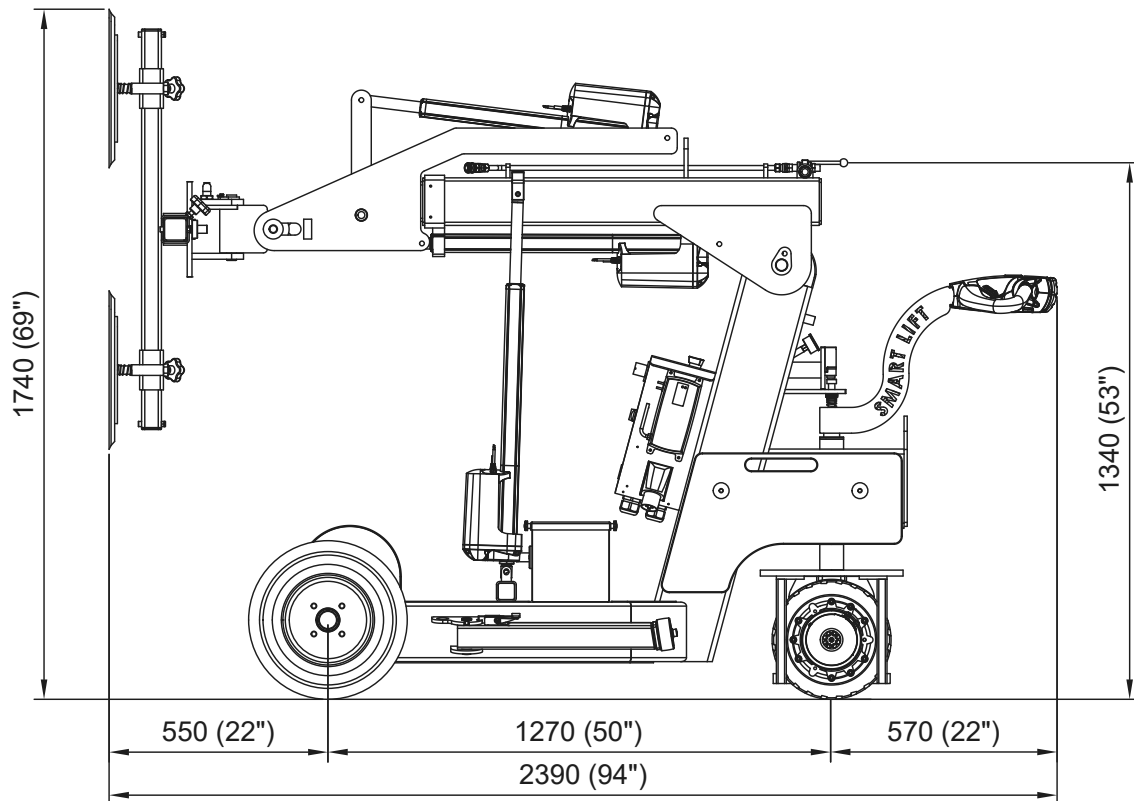
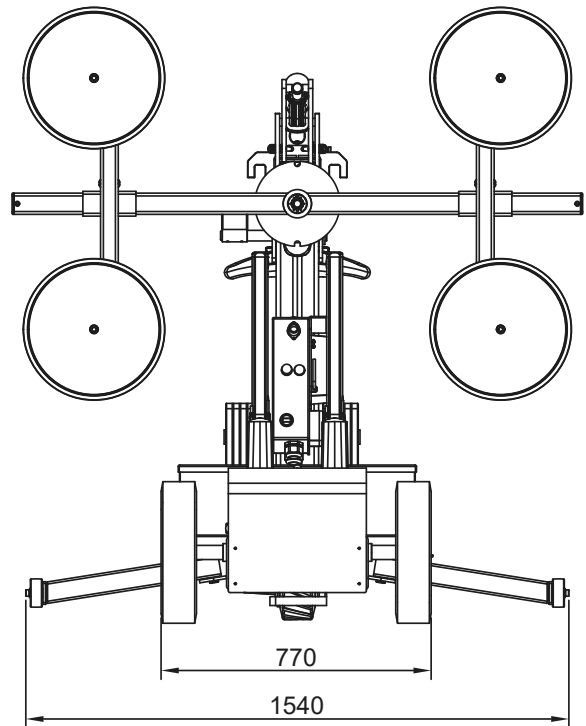

SL580 INDOOR

