

## SLI250 INDUSTRY

### Technical specifications

Lifting cap. arm in/out	250/130kg -550/290lb
Lifting height	3250mm / 128in
Extension of arm	900mm / 35in
Tilt	56° back / 62° fwd
Side shift	-
Charging voltage	230 V / 110V
Charging time	Approx. 8 hrs
Running period	Up to 10 hrs
Rear-wheel drive	700W
Width	680mm / 27in
Curb weight	490kg / 1080lb

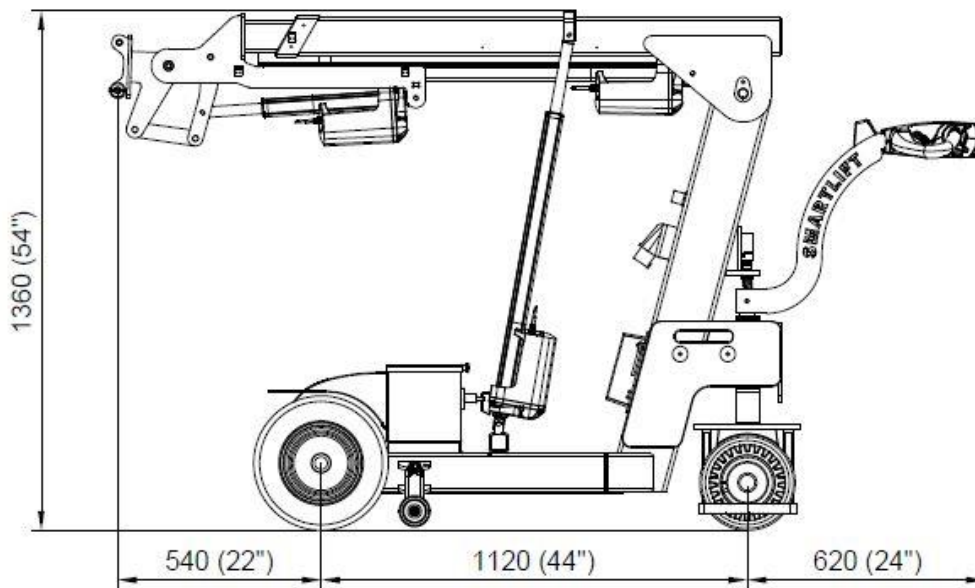
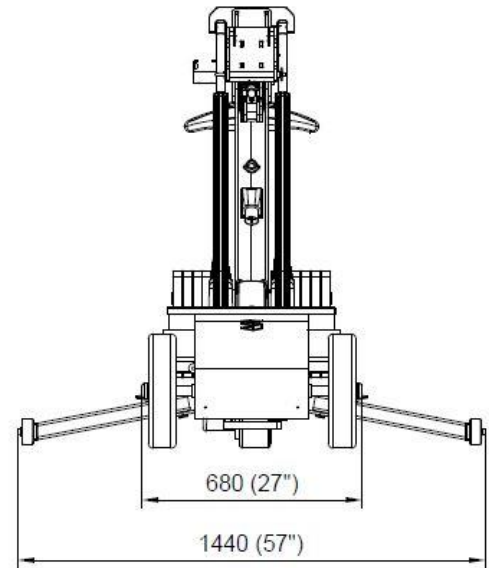

# Load chart

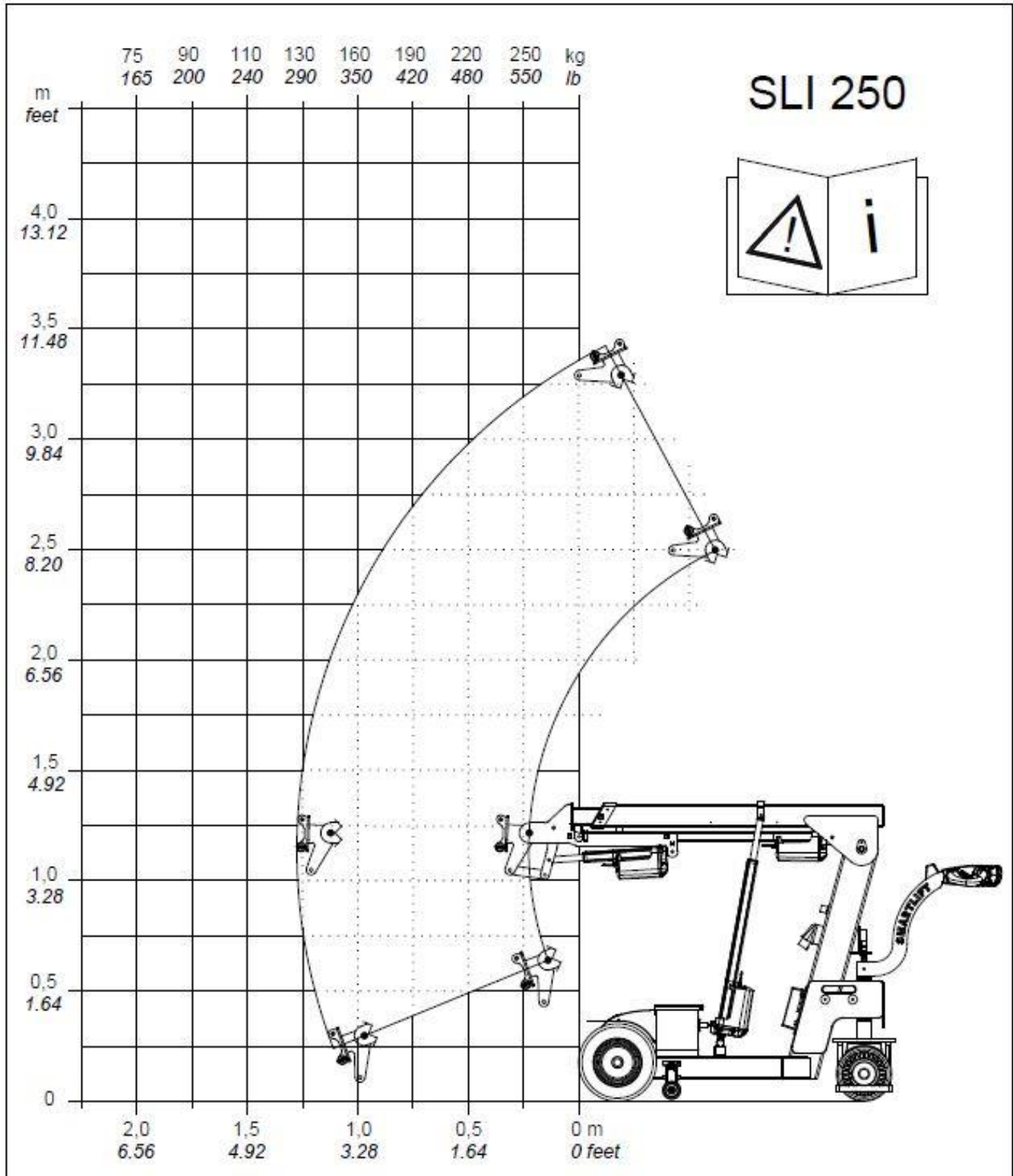

## SLI250 INDUSTRY HLE

### Technical specifications

Lifting cap. arm in/out	250/50kg - 550/110lb
Lifting height	4100mm / 161in
Extension of arm	900+900mm / 35+35in
Tilt	56° back / 62° fwd
Side shift	-
Charging voltage	230 V / 110V
Charging time	Approx. 8 hrs
Running period	Up to 10 hrs
Rear-wheel drive	700W
Width	680mm / 27in
Curb weight	550kg / 1210lb

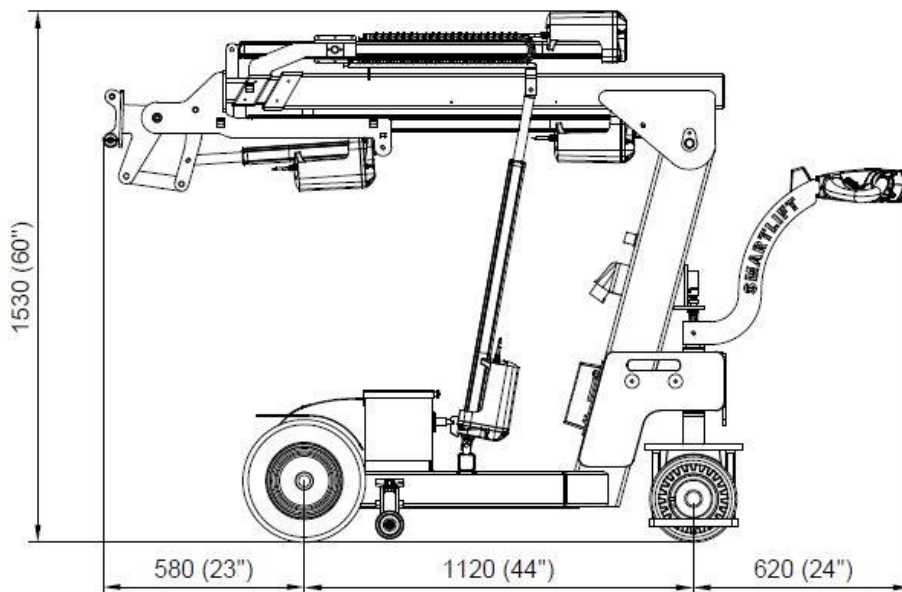
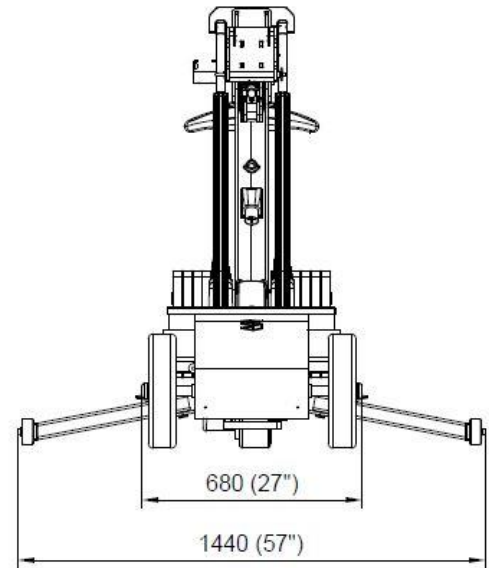

# Load chart

